

Café Barrier

CB-K-1500

CB-EXT-K-1500

The Café Barrier is an indoor/outdoor modular display system that includes heavy-duty stainless steel posts, base and 59" rails. This display system is a stylish way to define areas or direct traffic flow inside or outside restaurants, bars, retail establishments, airports, museums, casinos or at tradeshow. Unit kit, extension kit and individual components available.



use as outdoor café barriers



use for crowd control



use to guide traffic

features and benefits:

- **NEW**
- indoor/outdoor modular display system
- stylish way to define areas or direct traffic flow
- Easy to position, erect and remove
- Unit kit, extension kit and individual components available
- One year limited hardware warranty against manufacturer defects
- One year graphic limited warranty

dimensions:

Hardware

Assembled unit:
75.39" w x 37.6" h x 14.5" d
1915mm(w) x 955mm(h) x 368mm(d)

Base plate: 14.5" dia. x 1.59" h
368mm(dia.) x 40mm(h)

Upright: 36" l / 914mm(l)

Cross pole: 59" l / 1500mm(l)

Weight (includes graphic):
40 lbs / 18.14 kgs

Graphic

Total visual area:
53.25" w x 30.5" h
1350mm(w) x 775mm(h)

Pole pocket on top and bottom

Refer to related graphic template for more information.

Visit:
www.exhibitors-handbook.com/graphic-templates

Shipping

*See page 2 for full list of Cafe Barrier Kit shipping weights and dimensions

additional information:

Graphic material:
outdoor scrim or standard indoor vinyl

Not recommended for use in strong wind

CODES:
Café Barrier: CB-K-1500
Extension Kit: CB-EXT-K-1500
Base: CB-BASE
Upright: CB-UPRIGHT
Cross Bar: CB-BAR-1500

We are continually improving and modifying our product range and reserve the right to vary the specifications without prior notice. All dimensions and weights quoted are approximate and we accept no responsibility for variance. E&OE. See Graphic Templates for graphic bleed specifications.

Shipping:

CB-K-1500 KIT:	DIMENSIONS:	WEIGHT:
BOX 1 (2 CROSS POLES)	60"l x 2"h x 2"d 1524mm(l) x 51mm(h) x 51mm(d)	4 lbs / 1.8 kgs
BOX 2 (2 UPRIGHTS)	38"l x 9"h x 5"d 965mm(l) x 229mm(h) x 127mm(d)	6 lbs / 2.7 kgs
BOX 3 (2 BASES)	15"l x 15"h x 4"d 138mm(l) x 138mm(h) x 102mm(d)	28 lbs / 12.7 kgs
OCE	60"l x 18"h x 18"d 1524mm(l) x 457mm(h) x 457mm(d)	60 lbs / 27.2 kgs

CB-EXT-K-1500 KIT	DIMENSIONS:	WEIGHT:
BOX 1 (2 CROSS POLES)	60"l x 2"h x 2"d 1524mm(l) x 51mm(h) x 51mm(d)	4 lbs / 1.8 kgs
BOX 2 (1 UPRIGHT1)	38"l x 5"h x 5"d 965mm(l) x 127mm(h) x 127mm(d)	6 lbs / 2.7 kgs
BOX 3 (1 BASE)	15"l x 15"h x 2"d 138mm(l) x 138mm(h) x 51mm(d)	14 lbs / 6.4 kgs
OCE	60"l x 18"h x 18"d 1524mm(l) x 457mm(h) x 457mm(d)	43 lbs / 19.5 kgs

CB-K-1500 & CB-EXT-K-1500 KIT	DIMENSIONS:	WEIGHT:
BOX 1 (4 CROSS POLES)	60"l x 4"h x 4"d 1524mm(l) x 102mm(d) x 102mm(d)	8 lbs / 3.6 kgs
BOX 2 (2 UPRIGHTS)	38"l x 9"h x 5"d 965mm(l) x 229mm(h) x 127mm(d)	6 lbs / 3.6 kgs
BOX 3 (1 UPRIGHT)	38"l x 5"h x 5"d 965mm(l) x 127mm(h) x 127mm(d)	3 lbs / 1.4 kgs
BOX 4 (2 BASES)	15"l x 15"h x 4"d 138mm(l) x 138mm(h) x 102mm(d)	28 lbs / 12.7 kgs
BOX 5 (1 BASE)	15"l x 15"h x 2"d 138mm(l) x 138mm(h) x 51mm(d)	14 lbs / 6.4 kgs
OCE	62"l x 18"h x 18"d 1575mm(l) x 457mm(h) x 457mm(d)	82 lbs / 37.2 kgs

Pieces required for assembly

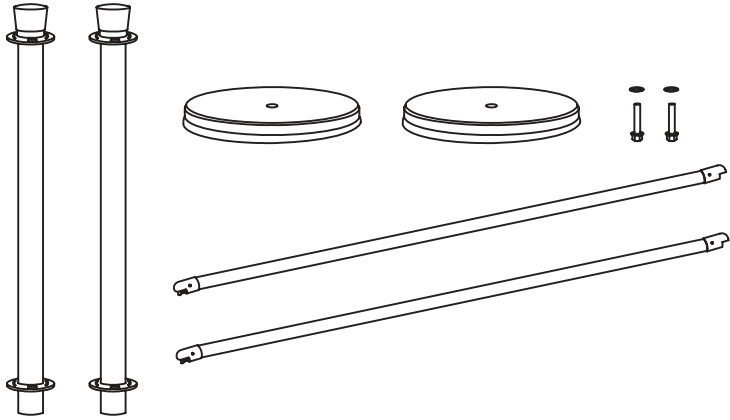

Set-up

