

# Formulate Master 20ft Horizontal 10ft Tall Fabric Backwall

## FMLT-WH2010

Formulate® is a collection of sophisticated, ergonomically designed exhibit booths. Formulate combines state-of-the-art zipper pillowcase dye-sublimated fabric coverings with advanced lightweight aluminum structures to provide unique design, functionality, and style. The excellence of the Formulate line of displays, hanging structures and products is simply unmatched. Stretch fabric graphics are hand-sewn, durable and dry-cleanable.



### features and benefits:

- State-of-the-art 30mm aluminum tube frame with snap button assembly
- Easy to store and ship
- Quick to set up
- Frame converts down to an 8' height
- 8' height graphic sold separately
- Kit includes: one frame, one dye-sublimated zipper pillowcase graphic, and one wheeled molded storage case
- Lifetime hardware warranty against manufacturer defects

### dimensions:

Hardware

Graphic

Assembled unit:  
226.60" w x 120.5" h x 54.91" d  
5756mm(w) x 3061mm(h) x 1395mm(d)

Approximate weight:  
59 lb / 27 kg

Refer to related graphic template for more information.

Visit:  
[www.exhibitors-handbook.com/graphic-templates](http://www.exhibitors-handbook.com/graphic-templates)

Shipping

### additional information:

Packing case(s):  
1 OCL

Shipping dimensions:  
57" l x 19" h x 19" d  
1448mm(l) x 483mm(h) x 483mm(d)

Approximate total shipping weight:  
82 lb / 38 kg

Graphic material:  
Dye-sublimation zipper pillowcase fabric

When included in a larger kit, a different packaging solution will be listed to accommodate all contents of the kit. Individual packaging no longer provided.

We are continually improving and modifying our product range and reserve the right to vary the specifications without prior notice. All dimensions and weights quoted are approximate and we accept no responsibility for variance. E&OE. See Graphic Templates for graphic bleed specifications.

# Included In Your Kit

Components, Connectors & Graphics

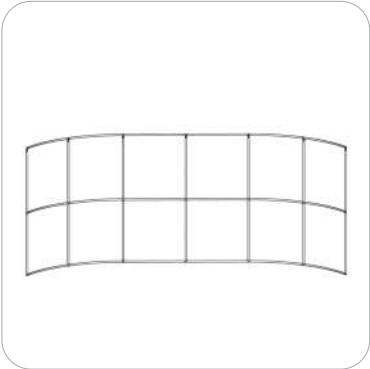

FMLT-WH20-F x1

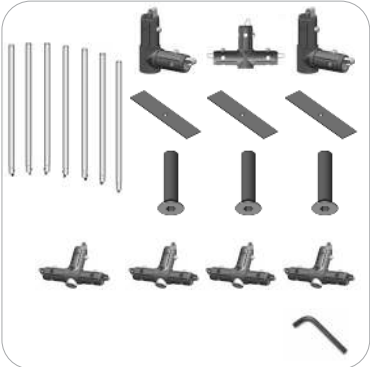

FMLT-10FT-EXT-7-HC x1

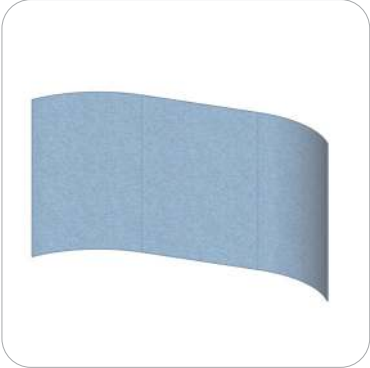

FMLT-WH2010-G x1

# Exploded View

FMLT-WH2010

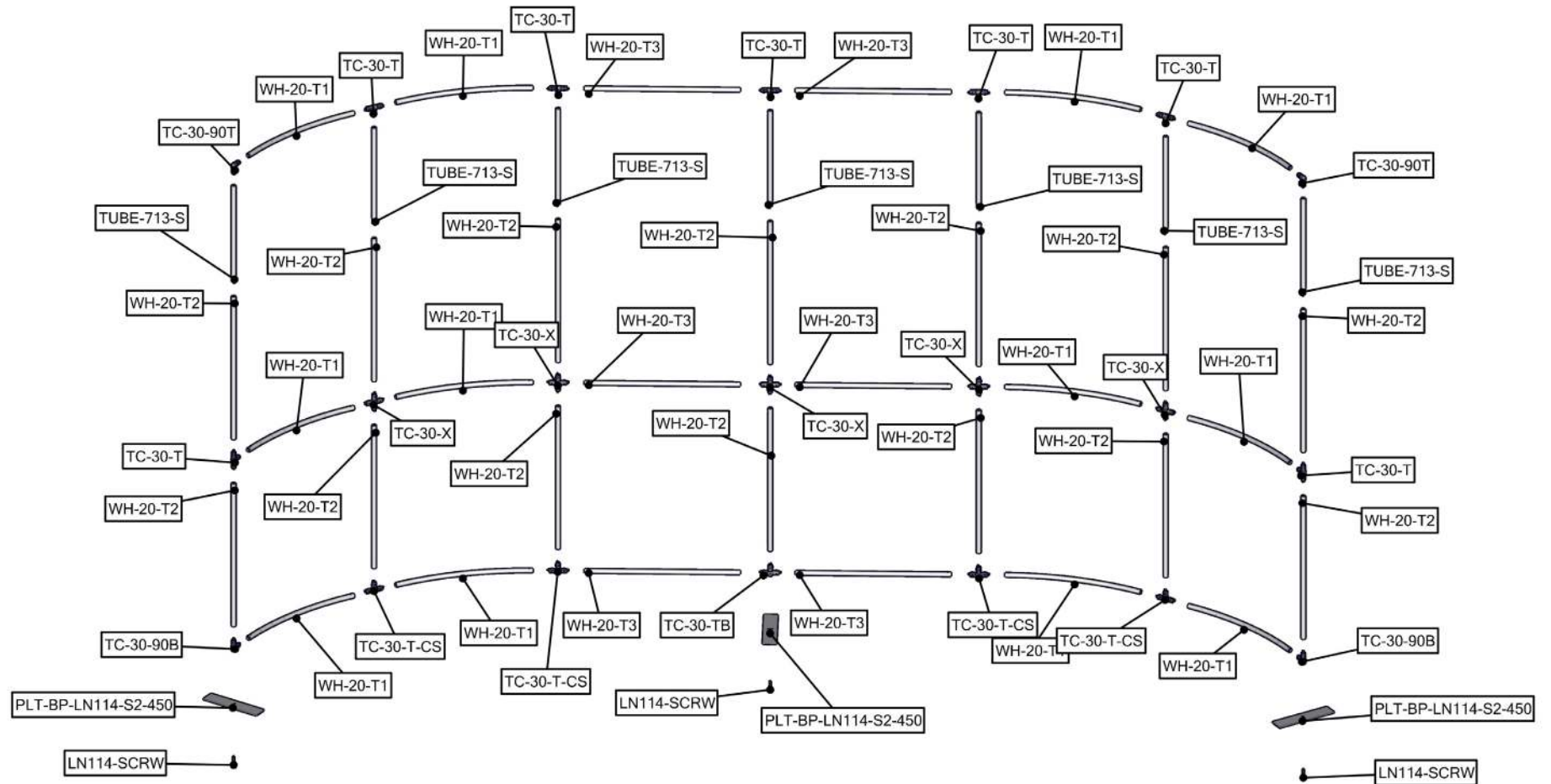

# Exploded View for 8' Height Frame Option

FMLT-WH10-F

8' height graphic sold separately

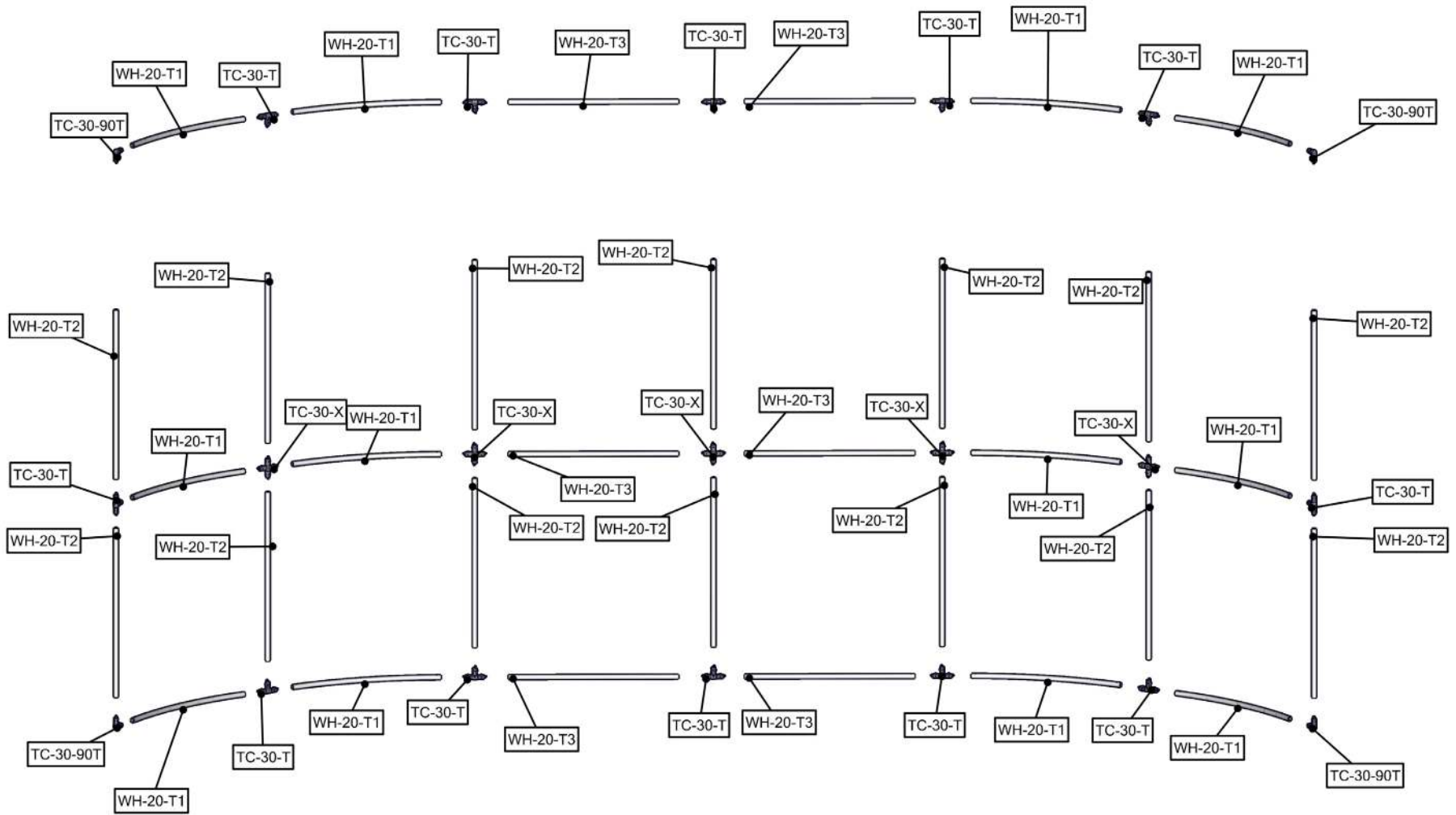

# Connection Methods

## Connection Method 1: TC-30-T

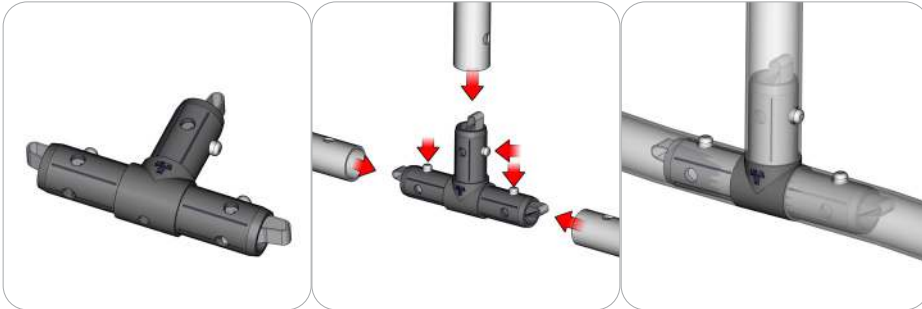

Take the plastic connector and make sure the snap buttons are in proper position for the frame tube holes. Simply press the snap button with your thumb and carefully slide the tube onto the connector. The snap button should pop through. Some twisting may be necessary to assure the snap button has popped all the way through the tube hole. Do not force the connection and be careful with the tube edges, they may be sharp.

## Connection Method 2: TC-30-90T

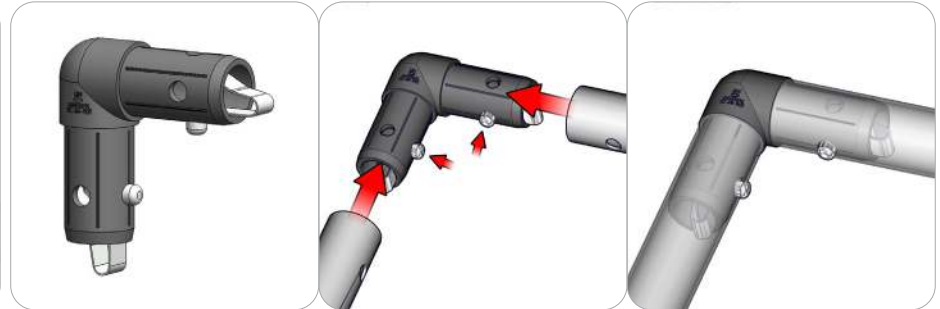

Take the plastic connector and make sure the snap buttons are in proper position for the frame tube holes. Simply press the snap button with your thumb and carefully slide the tube onto the connector. The snap button should pop through. Some twisting may be necessary to assure the snap button has popped all the way through the tube hole. Do not force the connection and be careful with the tube edges, they may be sharp.

## Connection Method 3: TC-30-X

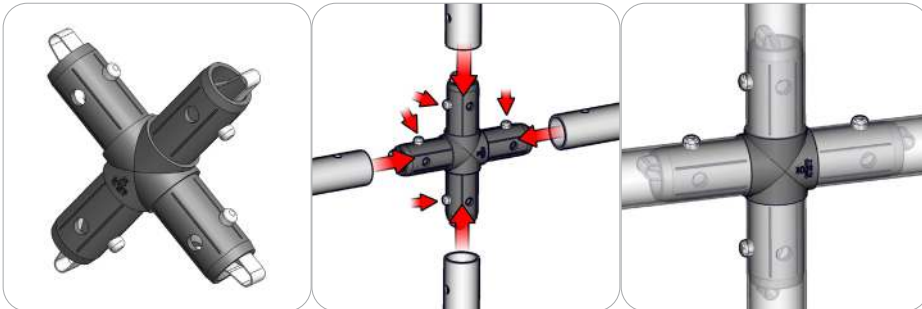

Take the plastic connector and make sure the snap buttons are in proper position for the frame tube holes. Simply press the snap button with your thumb and carefully slide the tube onto the connector. The snap button should pop through. Some twisting may be necessary to assure the snap button has popped all the way through the tube hole. Do not force the connection and be careful with the tube edges, they may be sharp.

## Connection Method 4: TC-30-90B

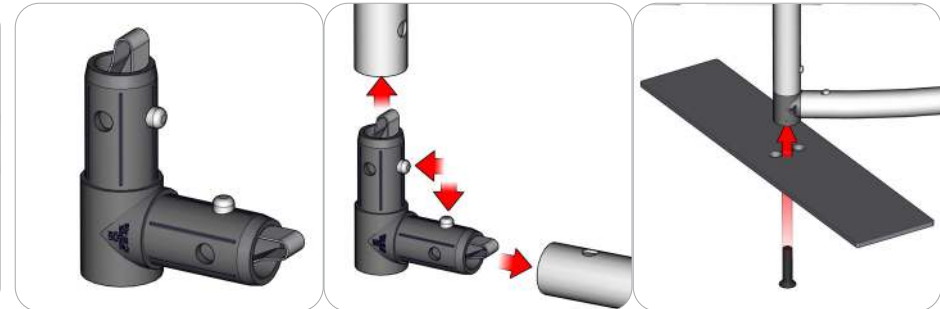

Take the plastic connector and make sure the snap buttons are in proper position for the frame tube holes. Simply press the snap button with your thumb and carefully slide the tube onto the connector. The snap button should pop through. Some twisting may be necessary to assure the snap button has popped all the way through the tube hole. Do not force the connection and be careful with the tube edges, they may be sharp.

With the plastic connector in secured place, use the provided hex key for attaching the base plate with the M10 screw. Once the base plate is in the desired position, tighten the set screw.

# Kit Assembly

## Step by Step

### Step 1.

Gather the components to build the frame. Use the Exploded View for part labels.

Reference Connection Method(s) 1, 2, 3 and 4 for more details.

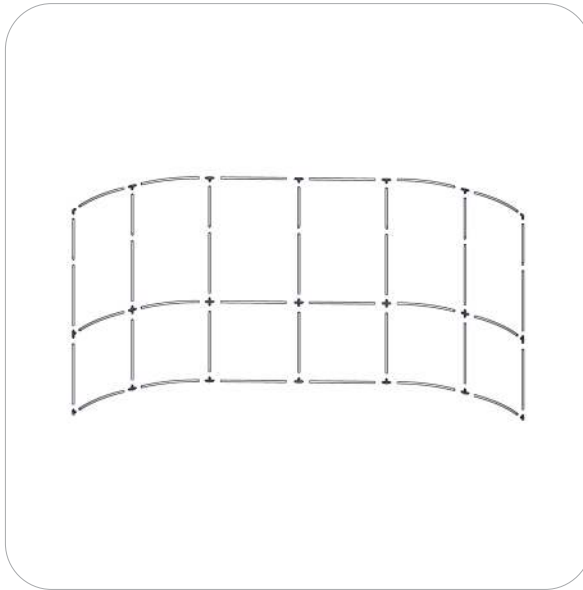
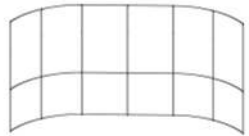

### Step 2.

Pull the pillowcase graphic over the frame and zipper it closed at the bottom.

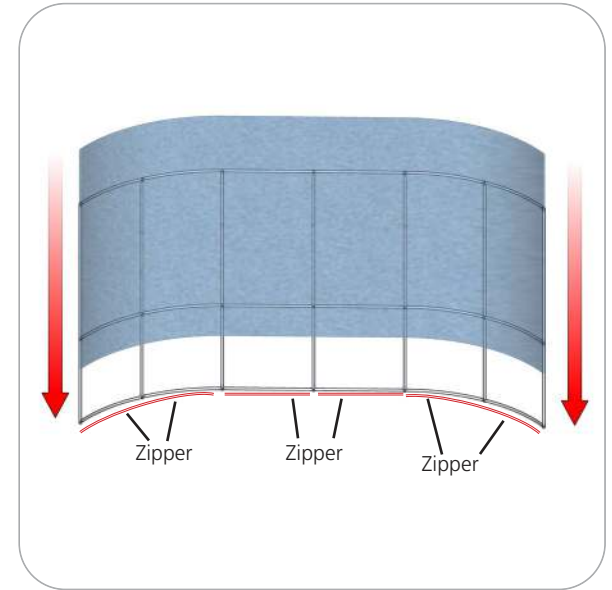

### Step 3.

Locate the stabilizing bases. Attach each foot to the bottom ends of the frame. Use the allen key tool provided to fasten the bases in place.

Reference Connection Method(s) 4 for more details.

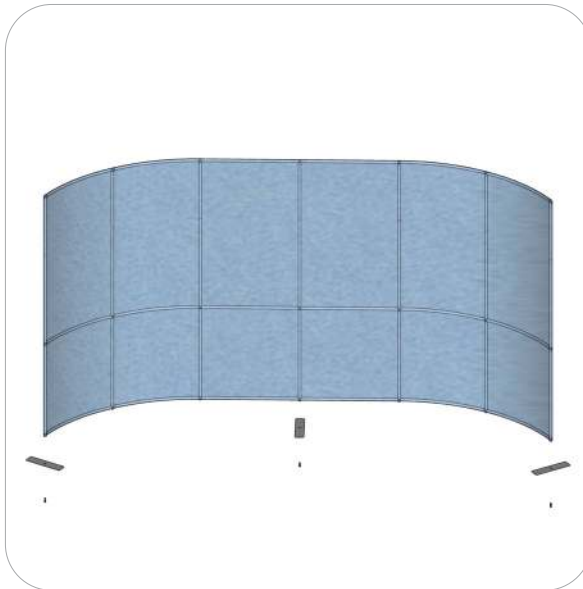

### Step 4.

Setup is complete.



# Formulate Master Backwall 2ft Height Extension Hardware

## TUBE-713-S

Your Formulate® Display Wall conveys your message and communicates your ideas to the world but what if the standard height just isn't enough? Now you have the option to add an additional 2 feet in height to most Formulate display walls creating the ultimate impact for your brand! Make the most of your message with an easy to assemble display addition that will attract attention from across the room.



### features and benefits:

- 30mm anodized silver extrusion
- Male end is swage fit with snap button
- Female end is open with hole for snap button
- Tool-less and easy to install snap button connections
- Converts an 8ft high backwall kit into a 10ft high back wall
- Lifetime hardware warranty against manufacturer defects

### dimensions:

Hardware

Graphic

30.34" w x 1.37" h x 1.16" d  
771mm(w) x 35mm(h) x 30mm(d)

Approximate weight:  
1 lb / 1 kg

Refer to related graphic template for more information.

Visit:  
[www.exhibitors-handbook.com/graphic-templates](http://www.exhibitors-handbook.com/graphic-templates)

Shipping

### additional information:

1 Box: 32" l x 5" h x 5" d  
813mm(l) x 127mm(h) x 127mm(d)

Approximate shipping weight(s):  
**TUBE-713-S**  
1 lb / 1 kg

**FMLT-10FT-EXT-3**  
2 lb / 1 kg

**FMLT-10FT-EXT-3-HC**  
11 lb / 5 kg

**FMLT-10FT-EXT-4-HC**  
12 lb / 6 kg

**FMLT-10FT-EXT-5**  
4 lb / 2 kg

**FMLT-10FT-EXT-7-HC**  
18 lb / 9 kg

When included in a larger kit, a different packaging solution will be listed to accommodate all contents of the kit. Individual packaging no longer provided.

We are continually improving and modifying our product range and reserve the right to vary the specifications without prior notice. All dimensions and weights quoted are approximate and we accept no responsibility for variance. E&OE. See Graphic Templates for graphic bleed specifications.



# Connection Methods

TUBE-713-S



First, notice that the 30mm tube spreader has been universally created to feature a swaged end and an open end to fit with most Formulate display wall frames.

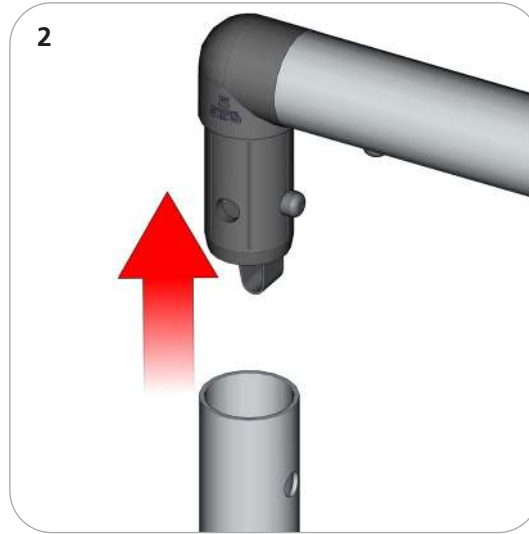

Second, disconnect the snap button connectors at the top of the display wall frame. Continue to remove the entire horizontal row of tubes.

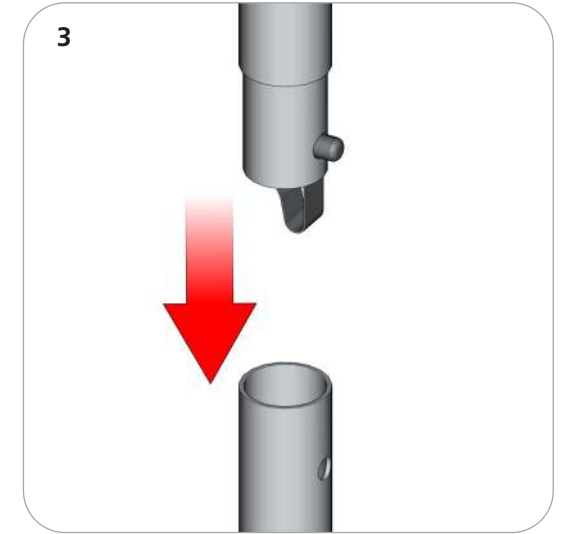

Third, take the male end of the spreader tube and snap it in place of the back wall snap button connectors.

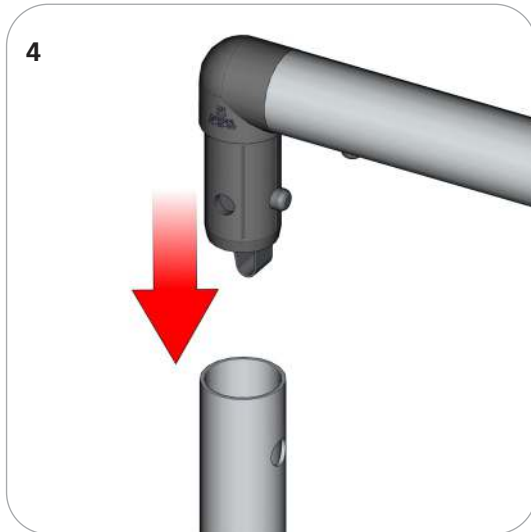

Fourth, take the male end of the plastic connector and snap it into the spreader tube open end.

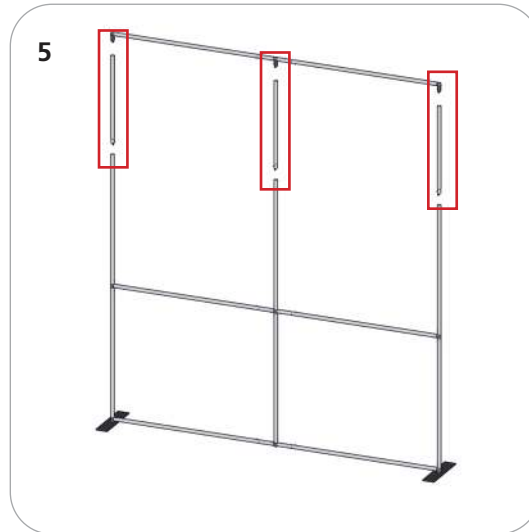

Fifth, repeat steps 2 - 4 for the rest of the back wall upright connections.

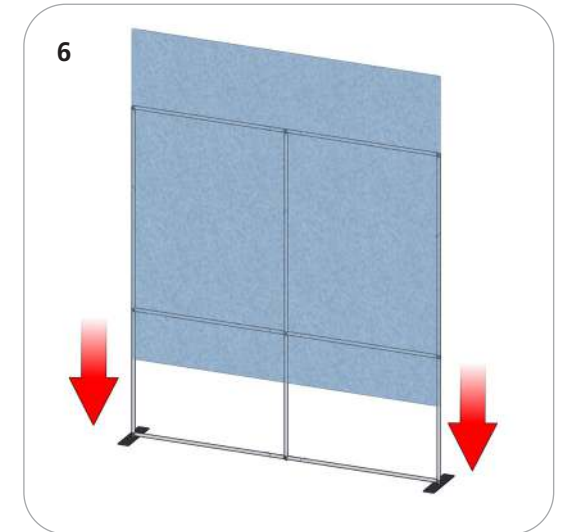

Sixth, apply the 10' high fabric pillowcase over the back frame and zipper it closed.