

Formulate 10' Horizontal Curve

FMLT-WH10-01

Formulate® is a collection of sophisticated, ergonomically designed exhibit booths. Formulate combines state-of-the-art zipper pillowcase dye-sublimated fabric coverings with advanced lightweight aluminum structures to provide unique design, functionality, and style. The excellence of the Formulate line of displays, hanging structures and products is simply unmatched. Stretch fabric graphics are hand-sewn, durable and dry-cleanable.



features and benefits:

- State-of-the-art 30mm aluminum tubing with push-button connectors
- Easy to store and ship
- Kit includes frame, dye-sublimated graphic and one wheeled molded case
- Lifetime hardware warranty against manufacturer defects

dimensions:

Hardware

Graphic

Assembled unit:
112" w x 92" h x 23" d
2847mm(w) x 2339mm(h) x 585mm(d)

Approximate weight:
26 lb / 12 kg

Refer to related graphic template for more information.

Visit:
www.exhibitors-handbook.com/graphic-templates

Shipping

additional information:

Shipping dimensions:
1 OCL :
57" l x 19" h x 19" d
1448mm(l) x 483mm(h) x 483mm(d)

Approximate shipping weight:
46 lb / 21 kg

Optional accessories:
Lumina 8-50 watt halogen lighting, literature pocket, stand-off graphic shelf, graphic header, larger freight cases

Graphic material:
Dye-sublimation zipper pillowcase fabric

When included in a larger kit, a different packaging solution will be listed to accommodate all contents of the kit. Individual packaging no longer provided.

We are continually improving and modifying our product range and reserve the right to vary the specifications without prior notice. All dimensions and weights quoted are approximate and we accept no responsibility for variance. E&OE. See Graphic Templates for graphic bleed specifications.

Included In Your Kit

Tools, Components, & Connectors



TC-30-90 x4

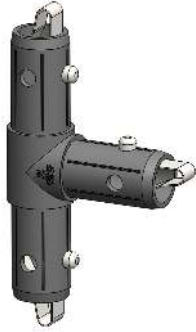

TC-30-T x6

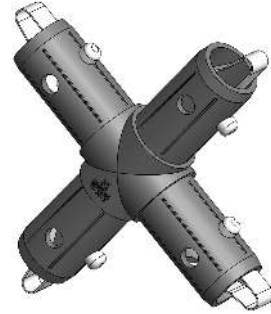

TC-30-X x2



WH10-01-T1 x9



WH10-01-T2 x8

Graphics



FMLT-WH10-01-G x1

Exploded View

FMLT-WH10-01

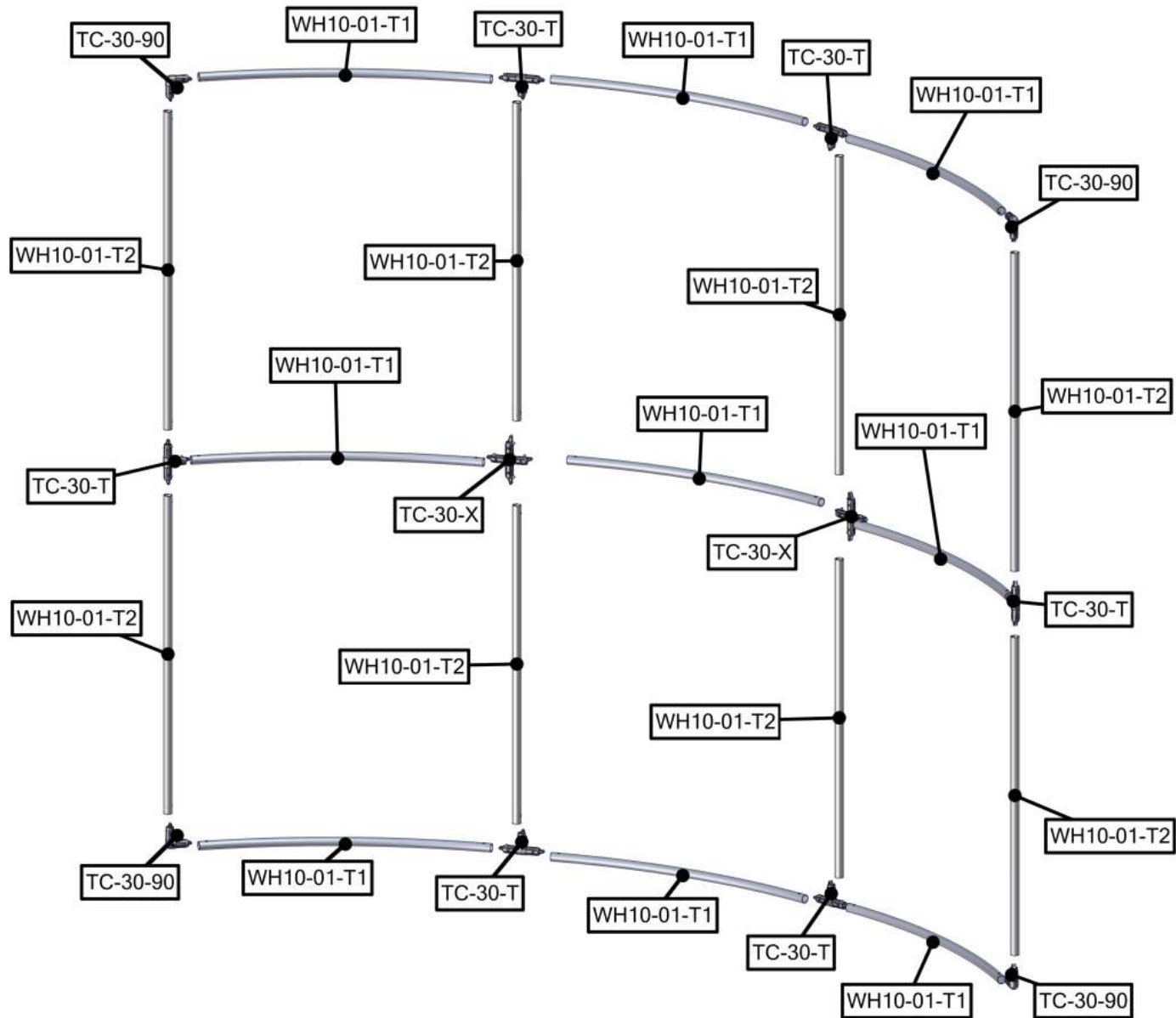

Labeling Diagram

FMLT-WH10-01

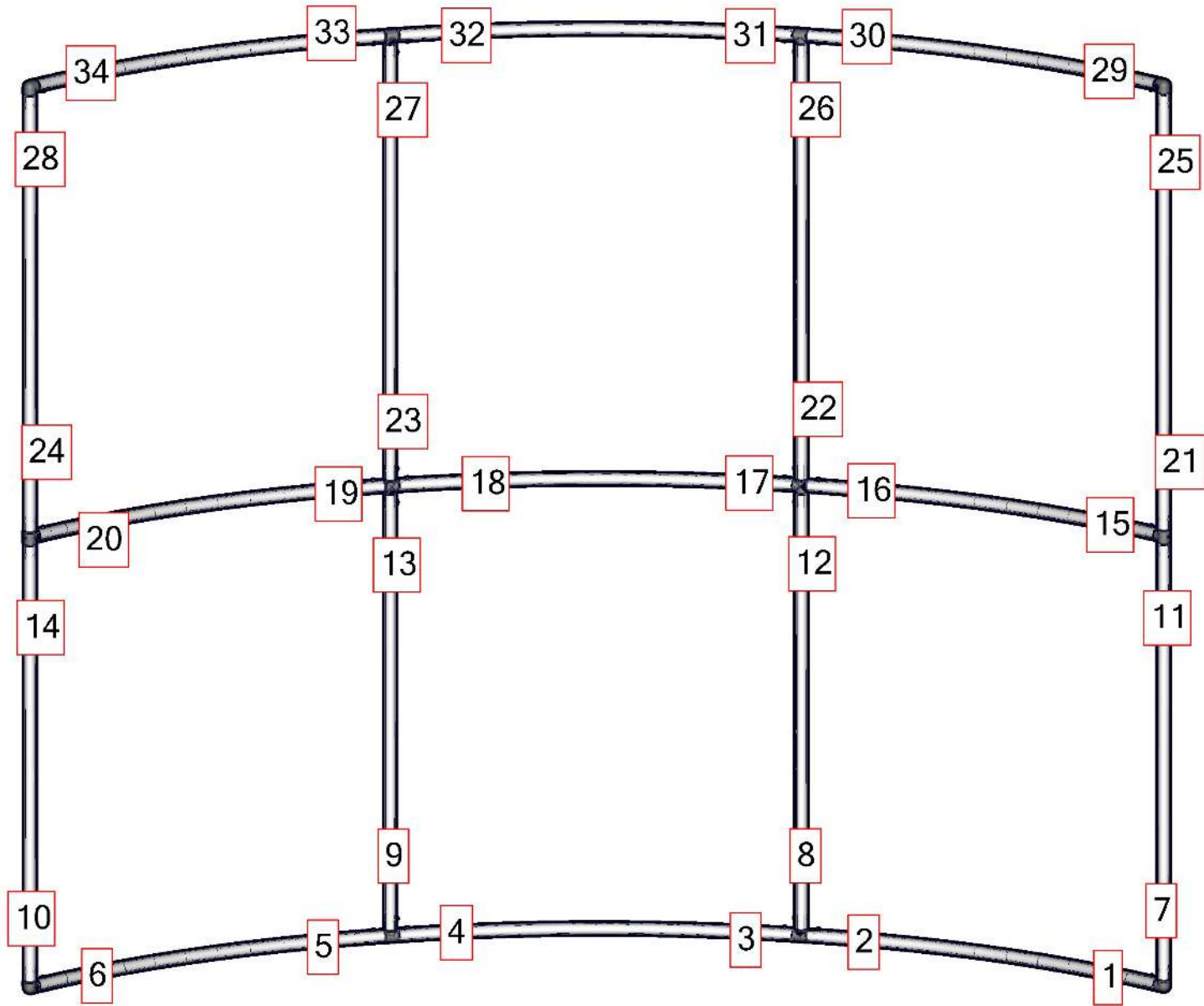

Connection Methods

Connection Method 1: TC-30-T

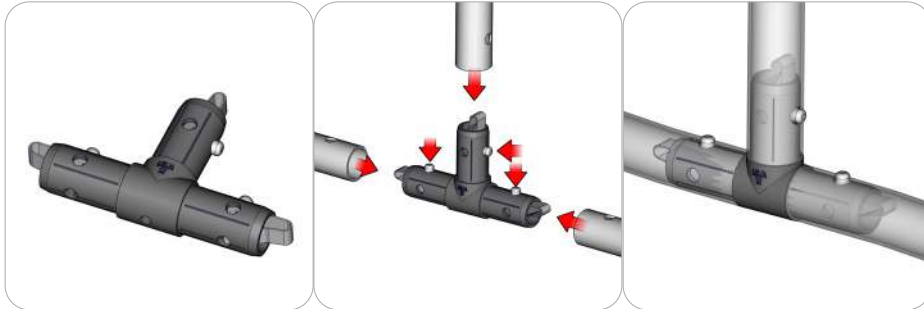

Take the plastic connector and make sure the snap buttons are in proper position for the frame tube holes. Simply press the snap button with your thumb and carefully slide the tube onto the connector. The snap button should pop through. Some twisting may be necessary to assure the snap button has popped all the way through the tube hole. Do not force the connection and be careful with the tube edges, they may be sharp.

Connection Method 2: TC-30-90T

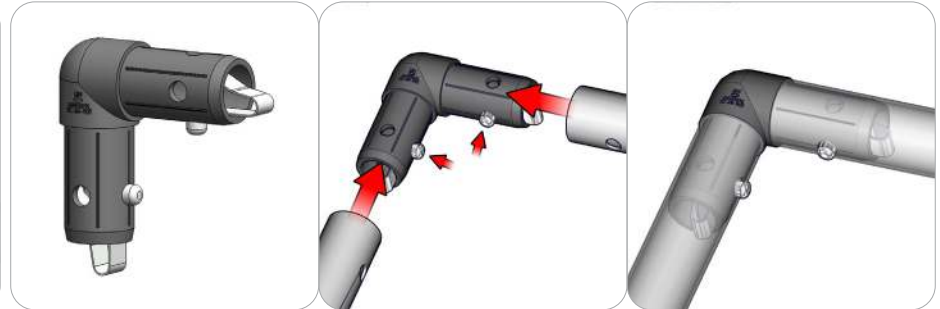

Take the plastic connector and make sure the snap buttons are in proper position for the frame tube holes. Simply press the snap button with your thumb and carefully slide the tube onto the connector. The snap button should pop through. Some twisting may be necessary to assure the snap button has popped all the way through the tube hole. Do not force the connection and be careful with the tube edges, they may be sharp.

Connection Method 3: TC-30-X

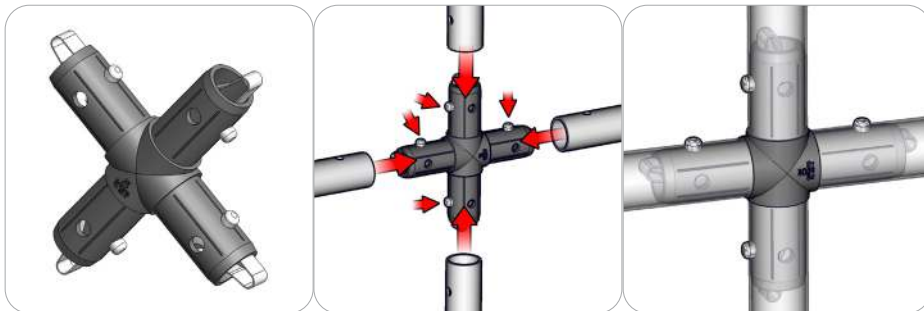

Take the plastic connector and make sure the snap buttons are in proper position for the frame tube holes. Simply press the snap button with your thumb and carefully slide the tube onto the connector. The snap button should pop through. Some twisting may be necessary to assure the snap button has popped all the way through the tube hole. Do not force the connection and be careful with the tube edges, they may be sharp.

Kit Assembly

Step by Step

Step 1.

Gather the tubes and the connecting components to assemble the bottom section of the frame.

Use the Exploded View and the Labeling Diagram for part labels.

Reference Connection Method(s) 1 and 2 for more details.

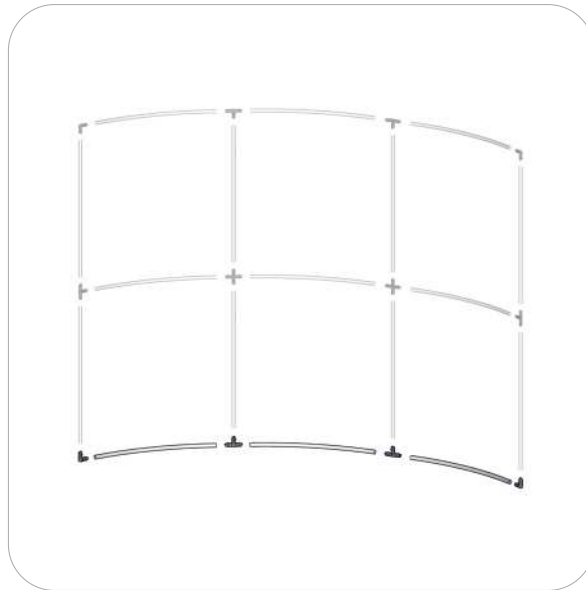

Step 2.

Gather the tubes and the connecting components to assemble the uprights to the bottom section of the frame.

Use the Exploded View and the Labeling Diagram for part labels.

Reference Connection Method(s) 1 and 3 for more details.

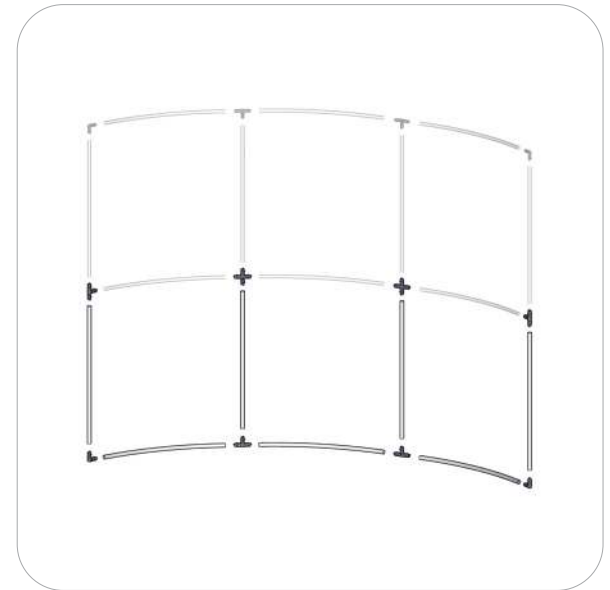

Step 3.

Gather the tubes and the connecting components to assemble the horizontal section of the frame.

Use the Exploded View and the Labeling Diagram for part labels.

Reference Connection Method(s) 1 and 3 for more details.

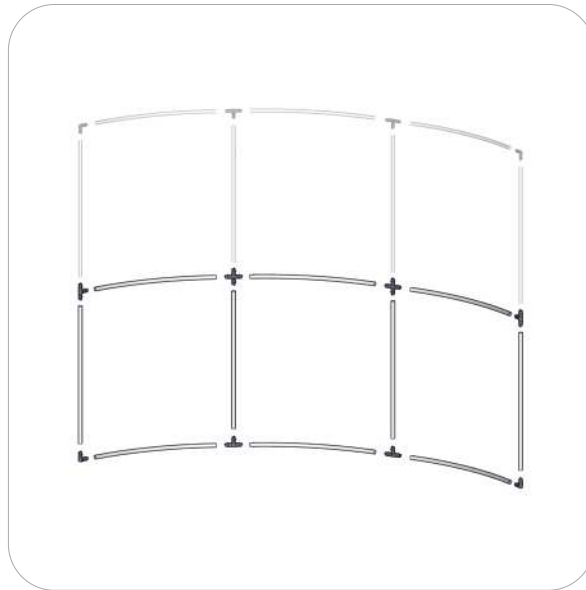

Step 4.

Gather the tubes and the connecting components to assemble the uprights and the top horizontal section of the frame.

Use the Exploded View and the Labeling Diagram for part labels.

Reference Connection Method(s) 1, 2 and 3 for more details.

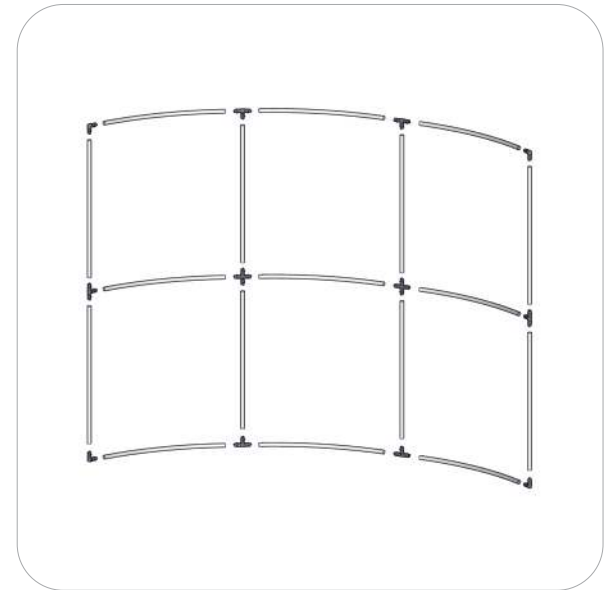
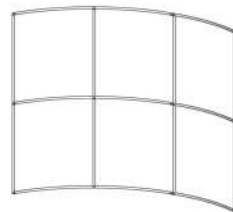

Kit Assembly

Step by Step - 10' Frame Option

Step 5.

Lay the frame flat out on the floor. Pull the pillowcase over the top of the frame. Zipper the pillowcase closed at the bottom.

Stand the frame upright.

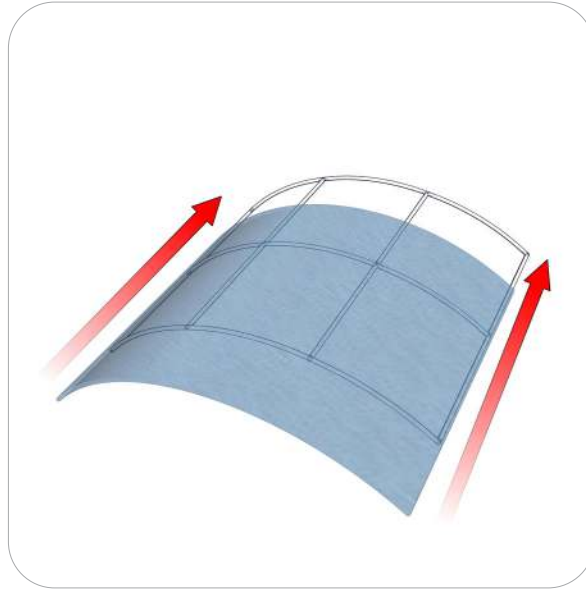
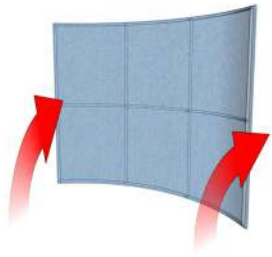

Step 6.

Setup is complete.

