

Formulate 20' x 20' Island Exhibit - Kit 05

CFAB-K-05

Formulate™ Fusion provides an unparalleled dynamic that elevates and accentuates a message and brand, but also maximizes the return on tradeshow investment. A fusion of FORM, FABRIC and FUNCTION, these kits combine organic and architectural shapes with state-of-the-art zipper pillowcase dye-sublimated fabric graphics to create unique, dynamic and functional island space.

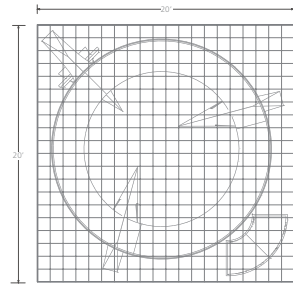

We are continually improving and modifying our product range and reserve the right to vary the specifications without prior notice. All dimensions and weights quoted are approximate and we accept no responsibility for variance. E&OE. See Graphic Templates for graphic bleed specifications.

features and benefits:

- 20' x 20' island exhibit
- 50mm aluminum tubing w/ heavy-duty spigot connectors
- Easily incorporate monitors and AV into the support structures to add multimedia
- Laminate counter with UV printed slat walls provides a welcoming reception area and lockable storage
- Kit includes: fabric covered tower centerpiece, zippered white fabric columns, laminate counter, three monitor mounts and 1 woodcrate
- Lifetime limited hardware warranty against manufacturer defects

dimensions:

Hardware	Graphic
Assembled unit: Cone Tower - 81" h x 202" dia. Support beams - 18' h Counter - 79.897" w x 40.5" h x 31.125" d	Total visual area: 209.453" w x 101.355" h (3) prints create one structure Tapered size: 88.703" h Please be sure to include 5" bleed around the perimeter.
Shipping Shipping dimensions - ships in 1 woodcrate: 101" l x 49" h x 53" d 2565mm(l) x 1245mm(h) x 1346mm(d) Approximate shipping weight: (kit and case) 980 lbs / 444 kgs	Refer to related graphic template for more information. Visit: www.exhibitors-handbook.com/graphic-templates

additional information:

- Graphic material:
Dye-sublimated zipper pillowcase fabric
- Internal LED lights are not included, can be purchased a la carte.
- 3 large monitor mounts, can hold monitor 26-40" / max weight is 75 lbs each
- *Monitors and flooring not included

MONITOR MOUNT WITH (4) ACC60

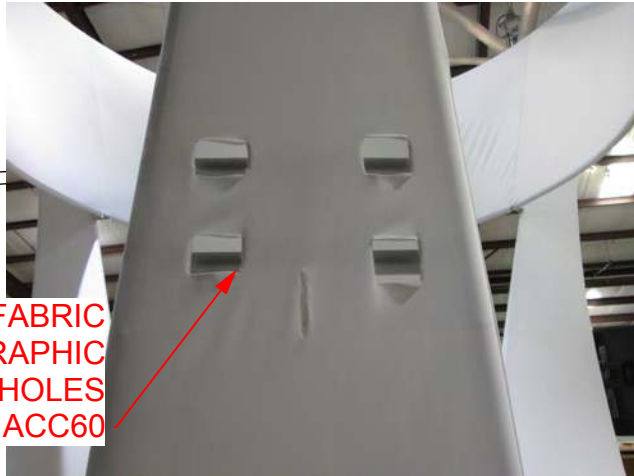
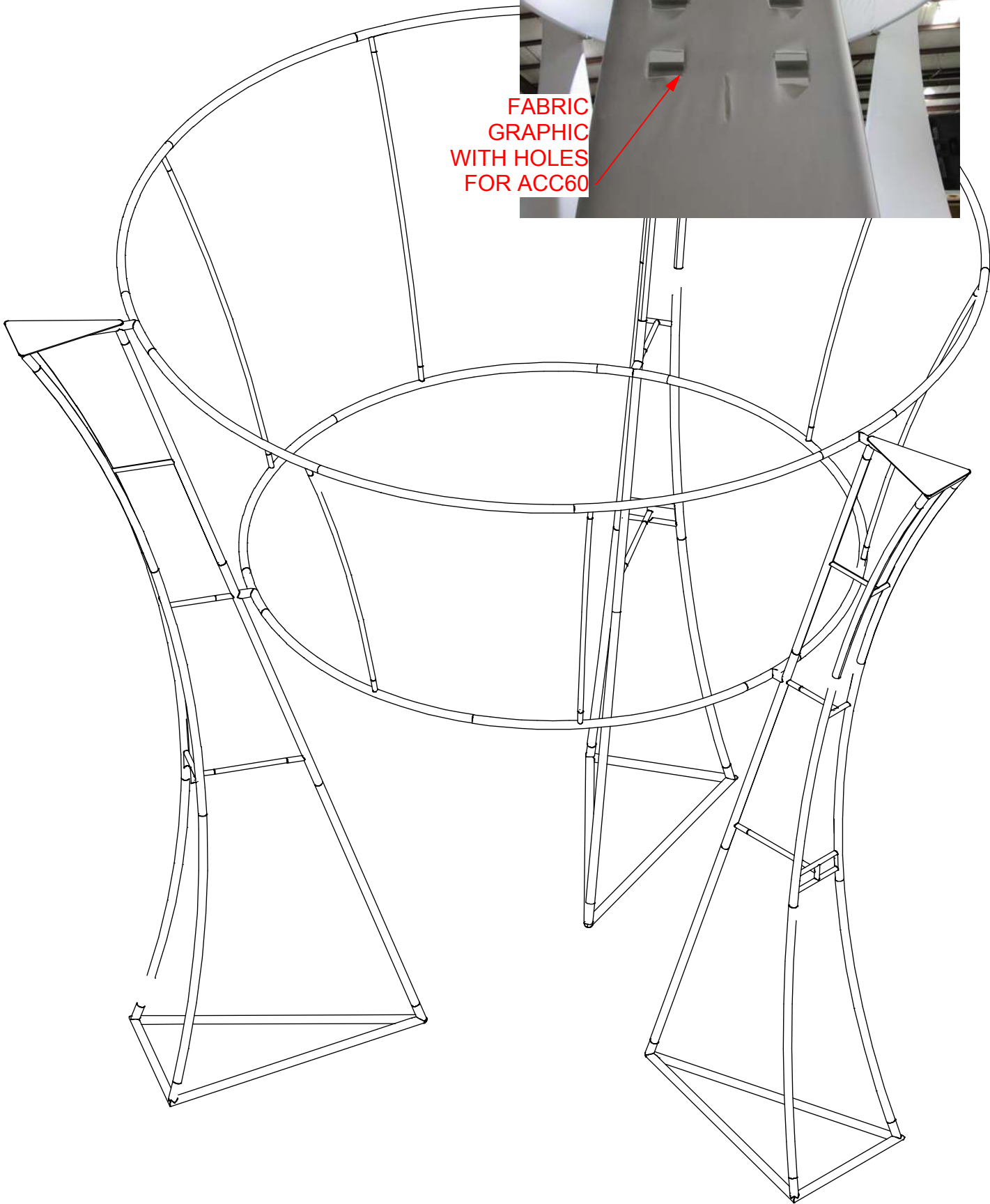

FABRIC GRAPHIC WITH HOLES FOR ACC60

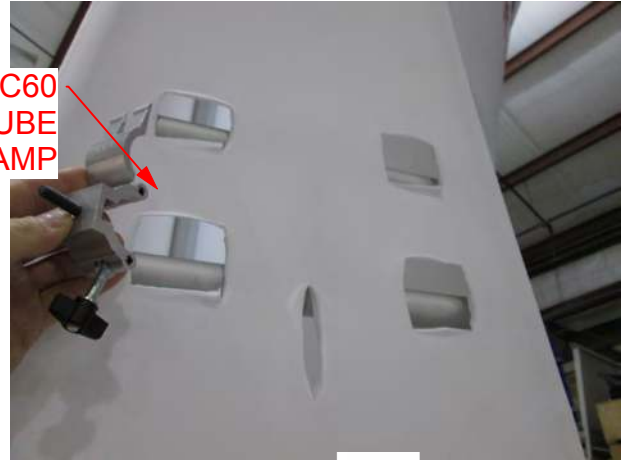

ACC60 TUBE CLAMP



WING NUTS AND WASHER

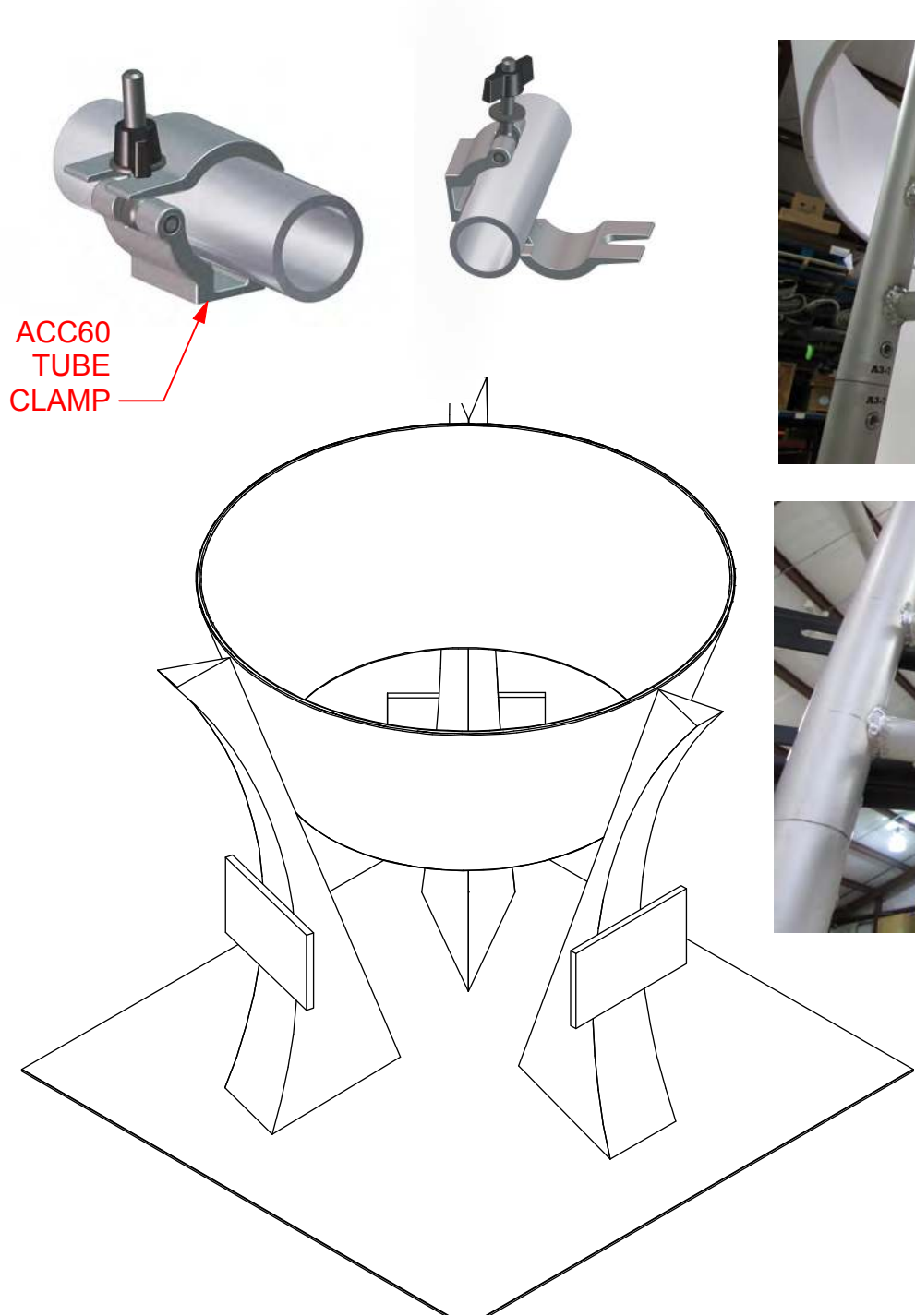

ACC60 TUBE CLAMP



Order #: **CFAB-K-05**

Client

Dist.

Dept.

Man.

Set up

Preview

Ship

Item	Qty
------	-----

Packing

Graphics Size

Project Manager

File Name

Detailer	Date
----------	------

Description

Frame constructed of 50mm tube w/ 30mm spreaders.
 Frame assembles with ES-50, ES-30 spigots.
 Fabric cover is pillowcase construction with zipper on one side.

MAX. ALLOWABLE TOLERANCES
 PER 2400mm FABRICATION = ±4mm

CHECKED BY: _____
 DATE: _____

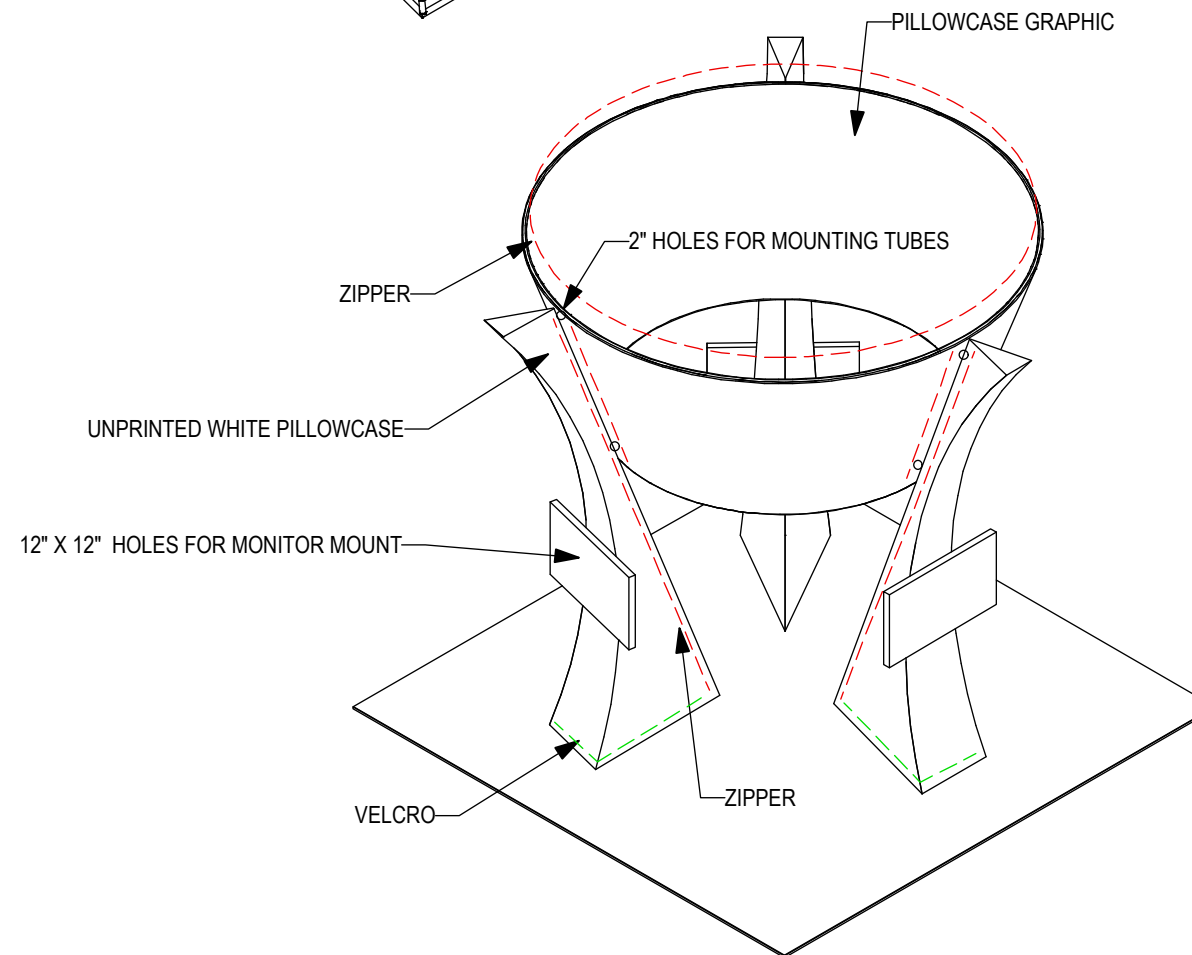
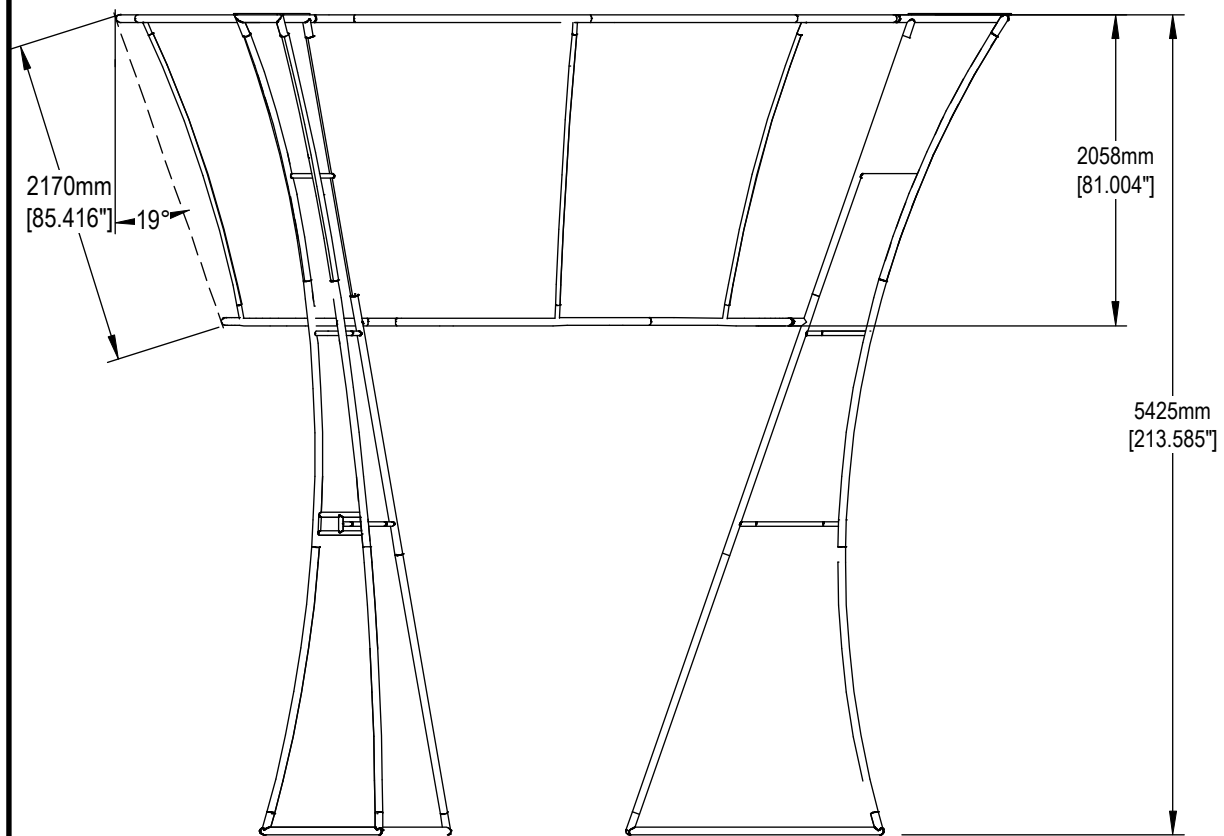
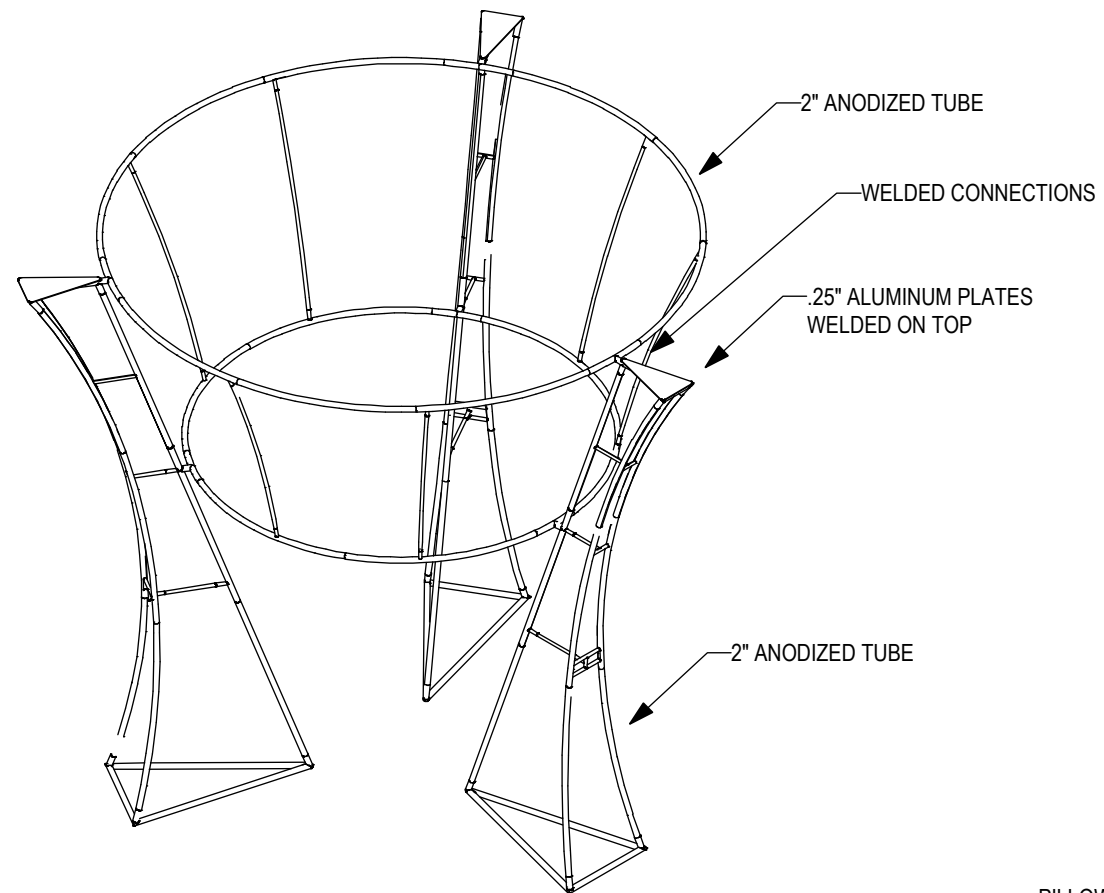
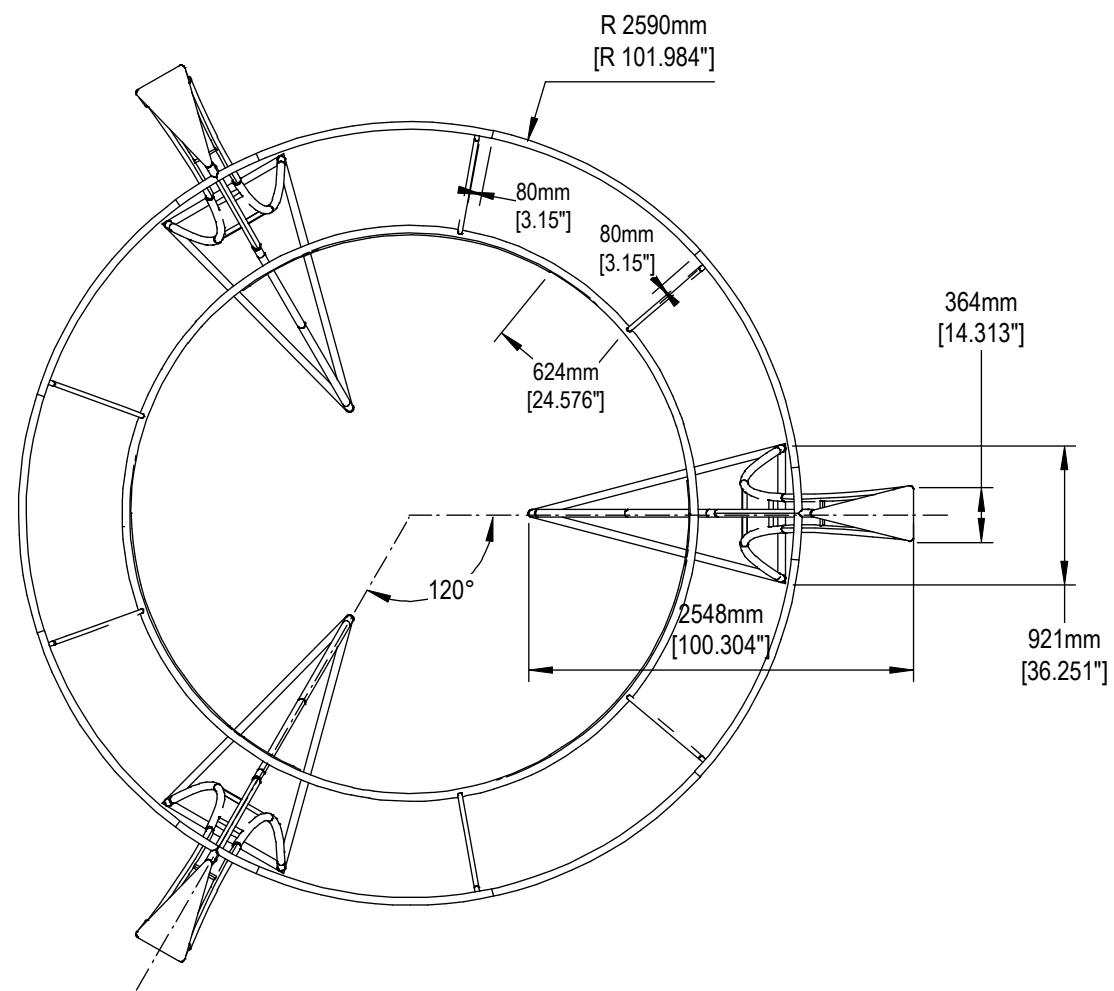

SET UP INSTRUCTIONS:

1. CONNECT BOTTOM AND TOP RAILS FOLLOWING THE LABELS
2. CONNECT SIDE RAILS
3. CLEAN THE FRAME AND PLACE THEM ON CLEAN PLACE
4. CAREFULLY REMOVE FABRIC COVER FROM BAGS
5. PLACE COVER AROUND THE BOTTOM OF THE FRAME
6. PULL COVER CAREFULLY UP TO THE TOP
7. CLOSE ALL ZIPPERS
8. ADJUST FABRIC AROUND THE FRAME

BREAK DOWN INSTRUCTIONS:

REVERSE SET-UP STEPS TO BREAKDOWN FRAME

FABRIC CARE INSTRUCTIONS:

1. UNZIP COVER ZIPPERS
2. CAREFULLY REMOVE FABRIC COVER
3. CLOSE ALL ZIPPERS
4. FOLD OR ROLL NEATLY
5. PLACE FABRIC IN COVER BAG

PART LIST:

- PER UNIT
- 7 50MM DIA. TUBE SECTIONS
 - 12 ES-50 EXPANDING SPIGOT
 - 1 5MM HEX KEY
 - 3 30MM DIA. TUBE SECTIONS
 - 6 ES-30 EXPANDING SPIGOT
 - 1 2.5MM HEX KEY
 - 1 FABRIC COVER

Frame A1, A2, A3 Assembly
Assemble frame as shown

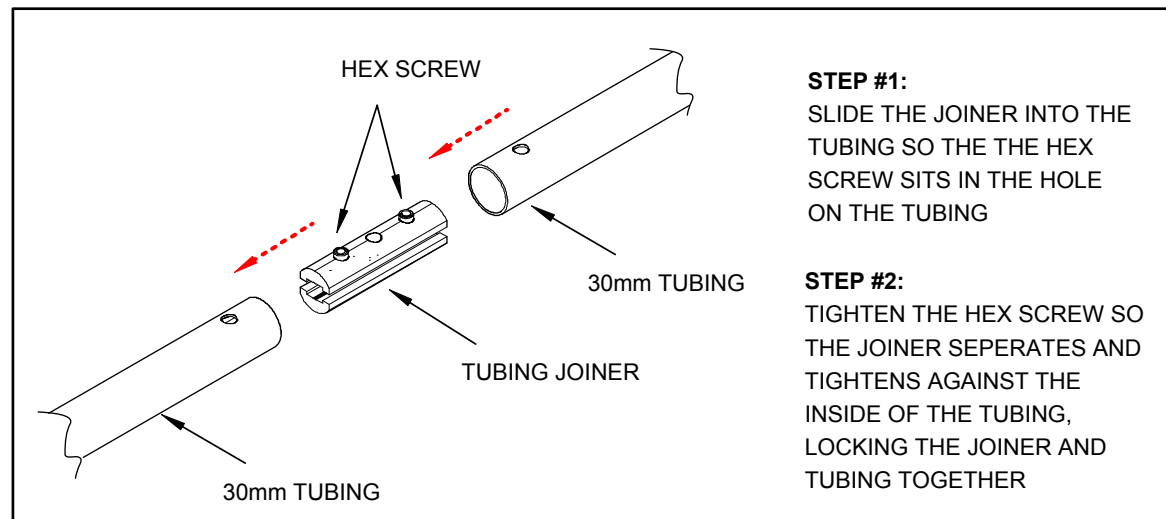
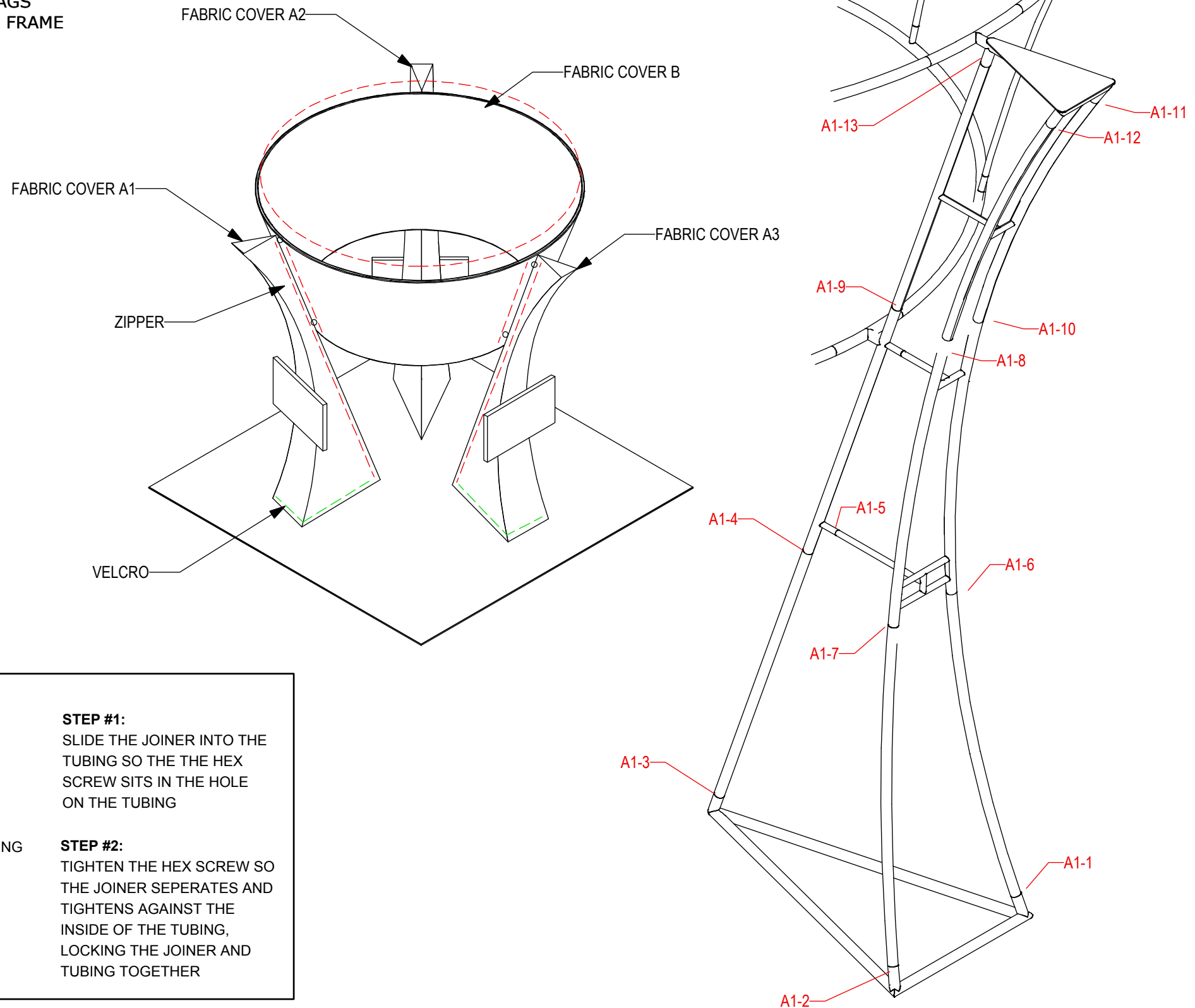

Client	
Dist.	
Dept.	
Man.	
Set up	
Preview	
Ship	
Item	Qty
Packing	
Graphics Size	
Project Manager	
File Name	
Detailer	Date

Description

Frame constructed of 50mm tube w/ 30mm spreaders.
Frame assembles with ES-50, ES-30 spigots.
Fabric cover is pillowcase construction with zipper on one side.

MAX. ALLOWABLE TOLERANCES
PER 2400mm FABRICATION = ±4mm

CHECKED BY: _____
DATE: _____



SET UP INSTRUCTIONS:

1. CONNECT BOTTOM AND TOP RAILS FOLLOWING THE LABELS
2. CONNECT SIDE RAILS
3. CLEAN THE FRAME AND PLACE THEM ON CLEAN PLACE
4. CAREFULLY REMOVE FABRIC COVER FROM BAGS
5. PLACE COVER AROUND THE BOTTOM OF THE FRAME
6. PULL COVER CAREFULLY UP TO THE TOP
7. CLOSE ALL ZIPPERS
8. ADJUST FABRIC AROUND THE FRAME

Assemble frame as shown

BREAK DOWN INSTRUCTIONS:

REVERSE SET-UP STEPS TO BREAKDOWN FRAME

FABRIC CARE INSTRUCTIONS:

1. UNZIP COVER ZIPPERS
2. CAREFULLY REMOVE FABRIC COVER
3. CLOSE ALL ZIPPERS
4. FOLD OR ROLL NEATLY
5. PLACE FABRIC IN COVER BAG

PART LIST:

- PER UNIT
- 15 50MM DIA. TUBE SECTIONS
 - 20 ES-50 EXPANDING SPIGOT
 - 1 5MM HEX KEY
 - 6 30MM DIA. TUBE SECTIONS
 - 12 ES-30 EXPANDING SPIGOT
 - 1 2.5MM HEX KEY
 - 1 FABRIC COVER

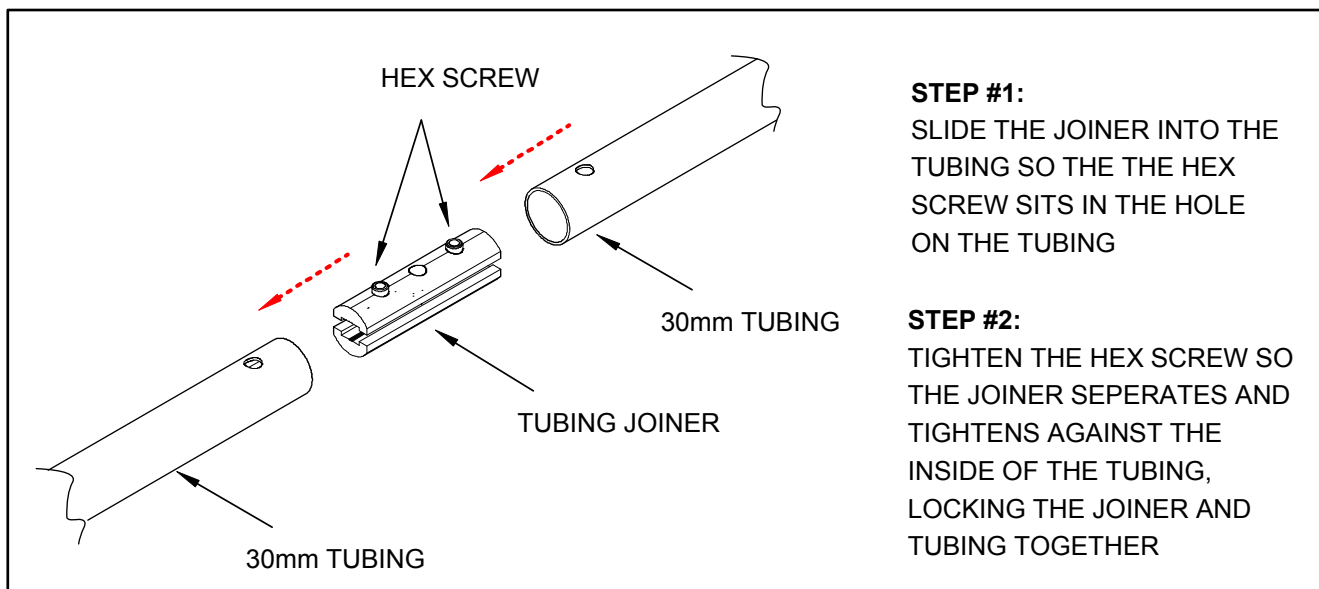
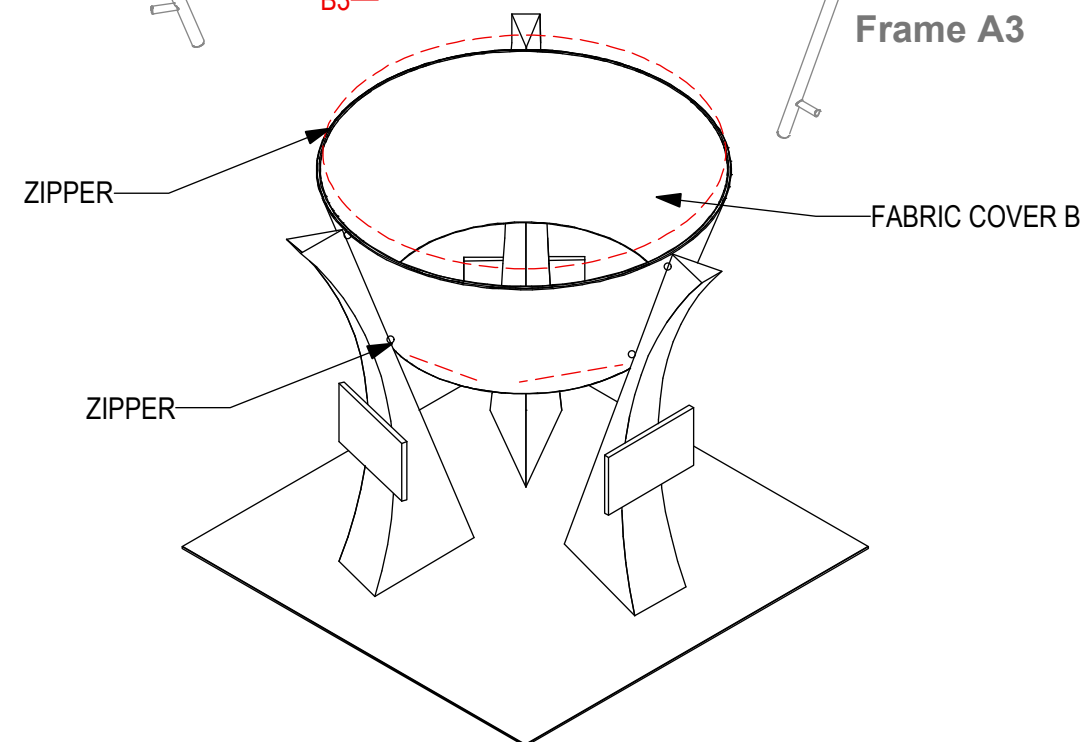
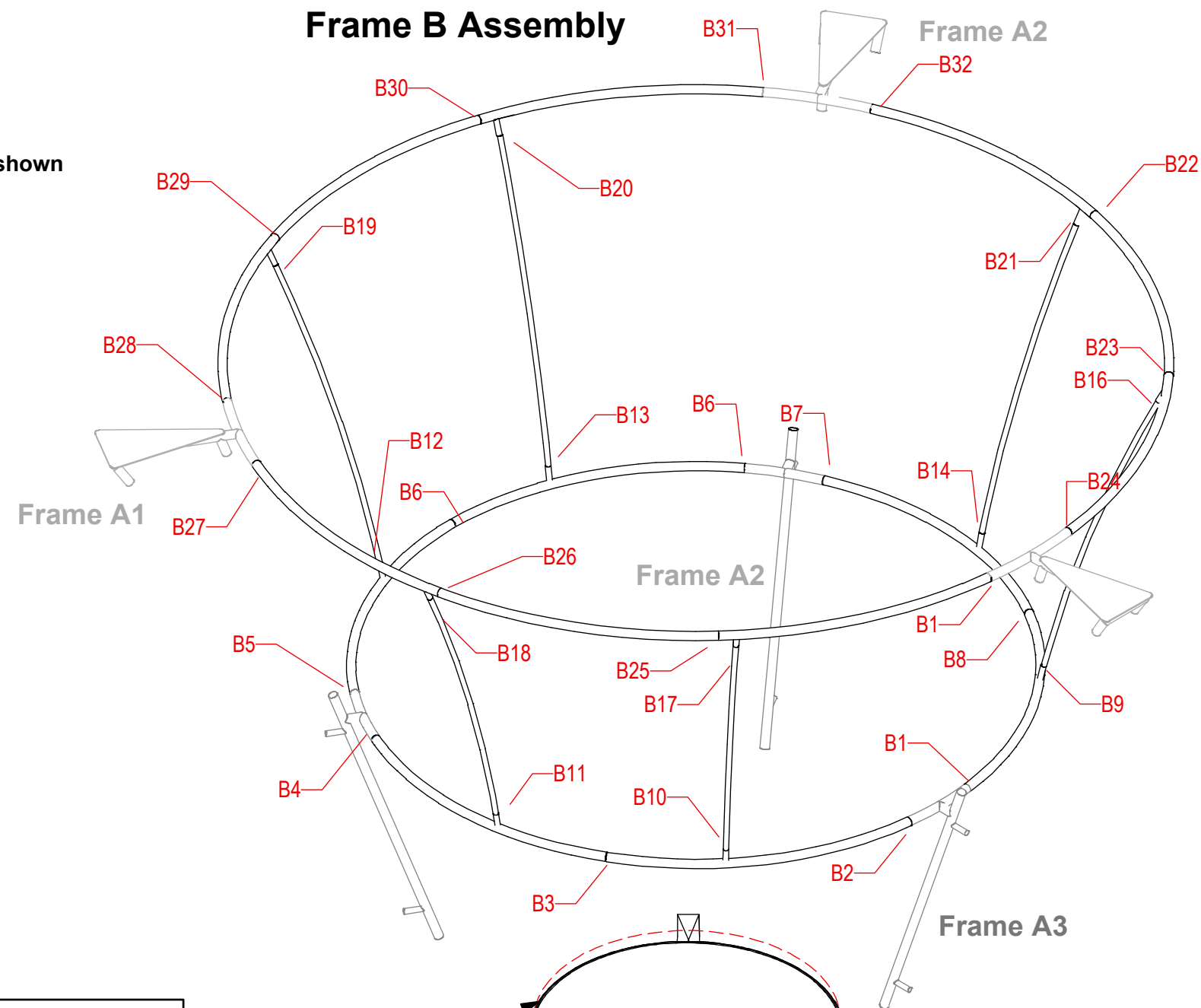

STEP #1:
SLIDE THE JOINER INTO THE TUBING SO THE THE HEX SCREW SITS IN THE HOLE ON THE TUBING

STEP #2:
TIGHTEN THE HEX SCREW SO THE JOINER SEPERATES AND TIGHTENS AGAINST THE INSIDE OF THE TUBING, LOCKING THE JOINER AND TUBING TOGETHER

Client	
Dist.	
Dept.	
Man.	
Set up	
Preview	
Ship	
Item	Qty
Packing	
Graphics Size	
Project Manager	
File Name	
Detailer	Date

Description

Frame constructed of 50mm tube w/ 30mm spreaders.
 Frame assembles with ES-50,ES-30 spigots.
 Fabric cover is pillowcase construction with zipper on one side.

MAX. ALLOWABLE TOLERANCES
 PER 2400mm FABRICATION = ±4mm

CHECKED BY: _____
 DATE: _____

**CFAB-K-05
COUNTER**

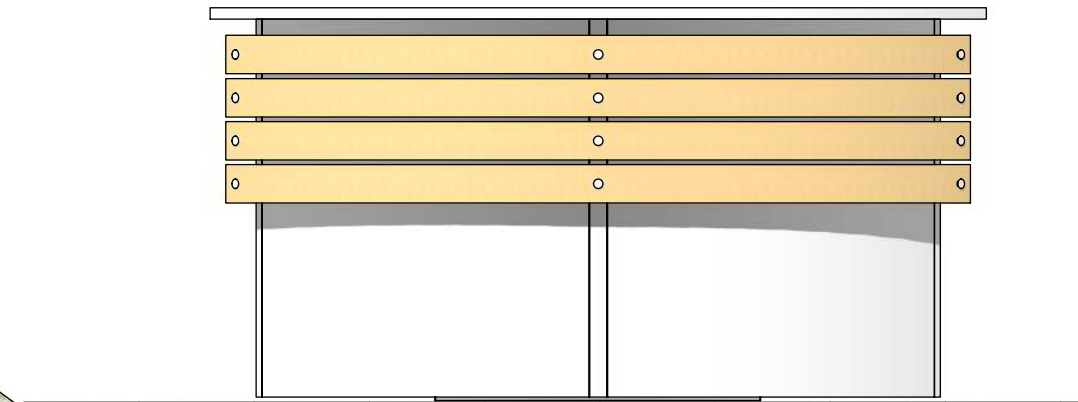
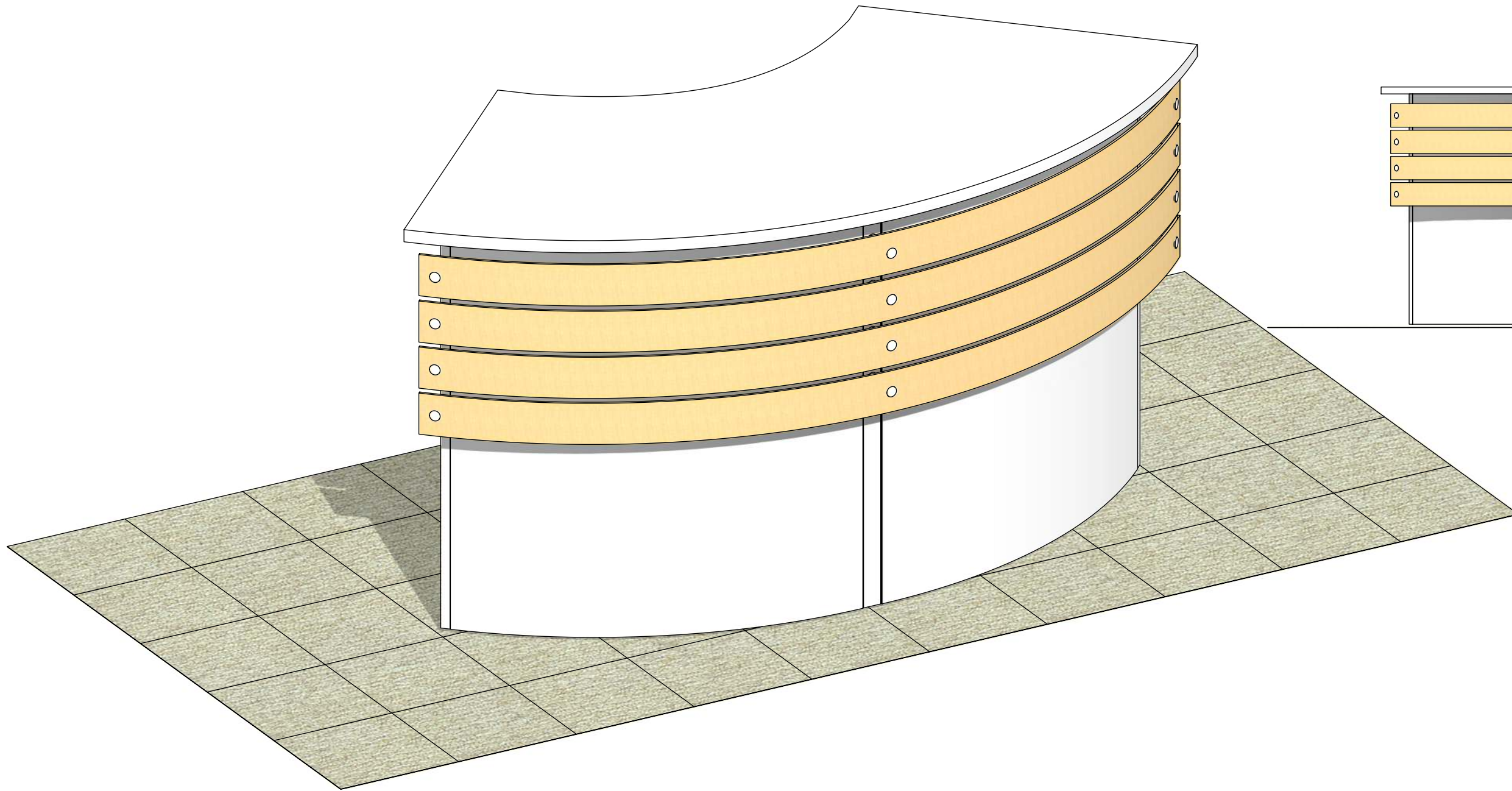

1. Redesign of this exhibit without approval by Origin may result in dangerous and unsafe structures. Origin disclaims any responsibility for redesigned exhibits it does not approve in writing.

2. Parts and components such as panels and extrusions are manufactured to metric sizing. Where ever possible sizes have been noted in feet and inches as well as in metric. Below is the imperial to metric sizing table as reference. "Nominal" refers to approximate size.

- | | |
|--------------------|-----------------------------------|
| 2400mm = (94 1/2") | ▼ Phone Line / Fax |
| 2100mm = (82 5/8") | ▼ Internet connection |
| 1800mm = (70 7/8") | ▼ Outlet |
| 1500mm = (59") | ▼ Main Drop (point of distrution) |
| 1200mm = (47 1/4") | |
| 900mm = (35 1/2") | |
| 600mm = (23 5/8") | |
| 300mm = (11 7/8") | |
- Wire running under carpet

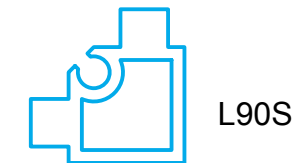
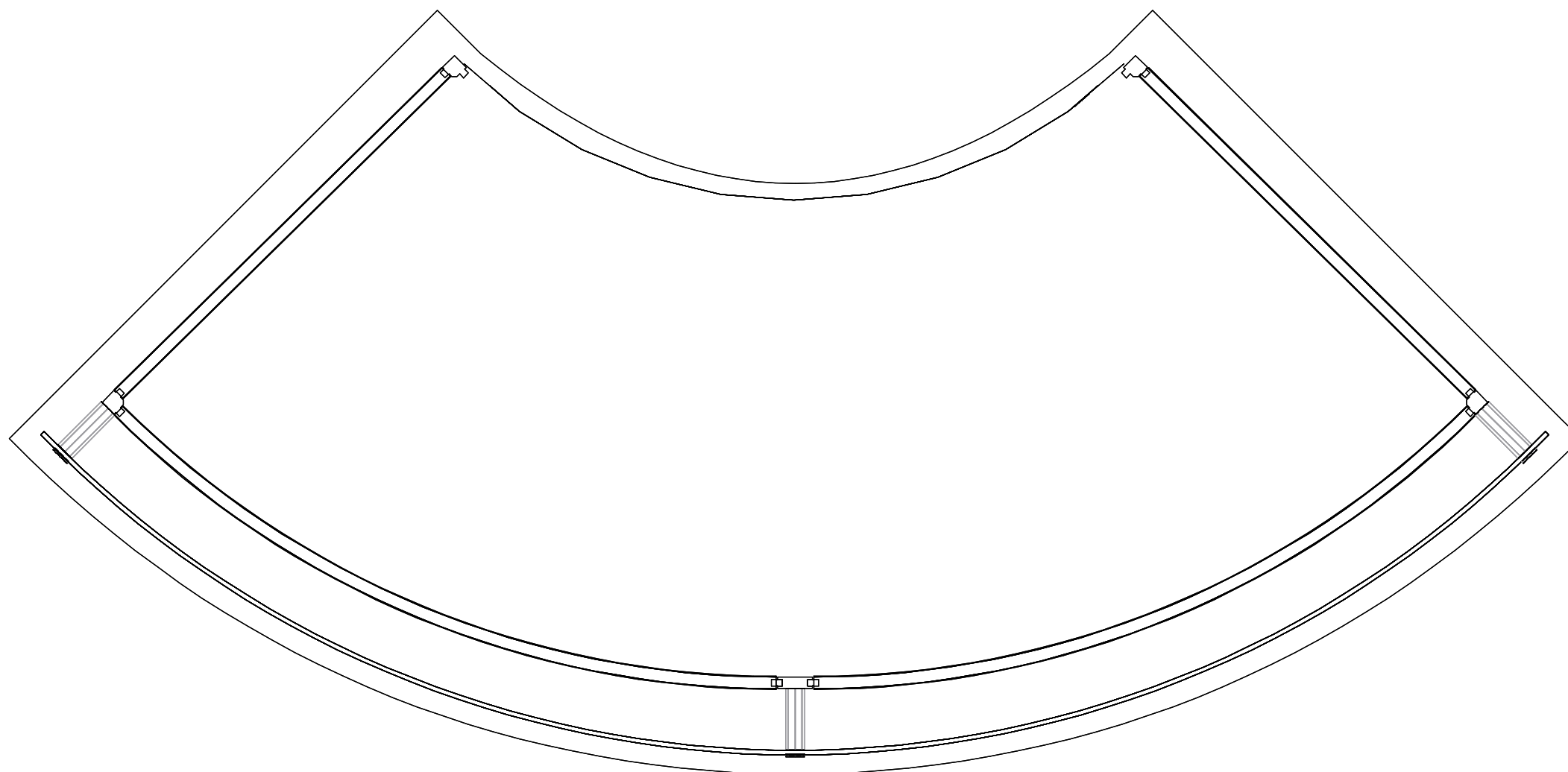

L90S



PH



L180N

COUNTER

Title: SET-UP INSTRUCTIONS

EP

Code	#	Description
A3	2	4R X1000MM (39.37") LAMINATE CURVE PANEL
L180N-1000	2	1000MM (39.37") 180N DEGREE SILVER LINK
CKSO-80MM	12	1" X 80MM STANDOFF
A4	1	1000MM (39.37") PH EXTRUSION - LAMINATED
A1	2	1000MM (39.37") X 600MM (23.62") LAMINATE PANEL
L90S-1000L	4	1000MM (39.37") 90 90 DEGREE SILVER LINK - LAMINATED
PL2R-4	1	2R X 1000MM (39.37") LAMINATE PANEL
A2	1	2'R X 1000MM(V) LAMINATE CABINET DOOR -CONCAVE

1. Redesign of this exhibit without approval by Origin may result in dangerous and unsafe structures. Origin disclaims any responsibility for redesigned exhibits it does not approve in writing.

2. Parts and components such as panels and extrusions are manufactured to metric sizing. Where ever possible sizes have been noted in feet and inches as well as in metric. Below is the imperial to metric sizing table as reference. "Nominal" refers to approximate size.

2400mm = (94 1/2")	Phone Line / Fax
2100mm = (82 5/8")	Internet connection
1800mm = (70 7/8")	Outlet
1500mm = (59")	Main Drop (point of distrution)
1200mm = (47 1/4")	
900mm = (35 1/2")	
600mm = (23 5/8")	
300mm = (11 7/8")	

--- Wire running under carpet

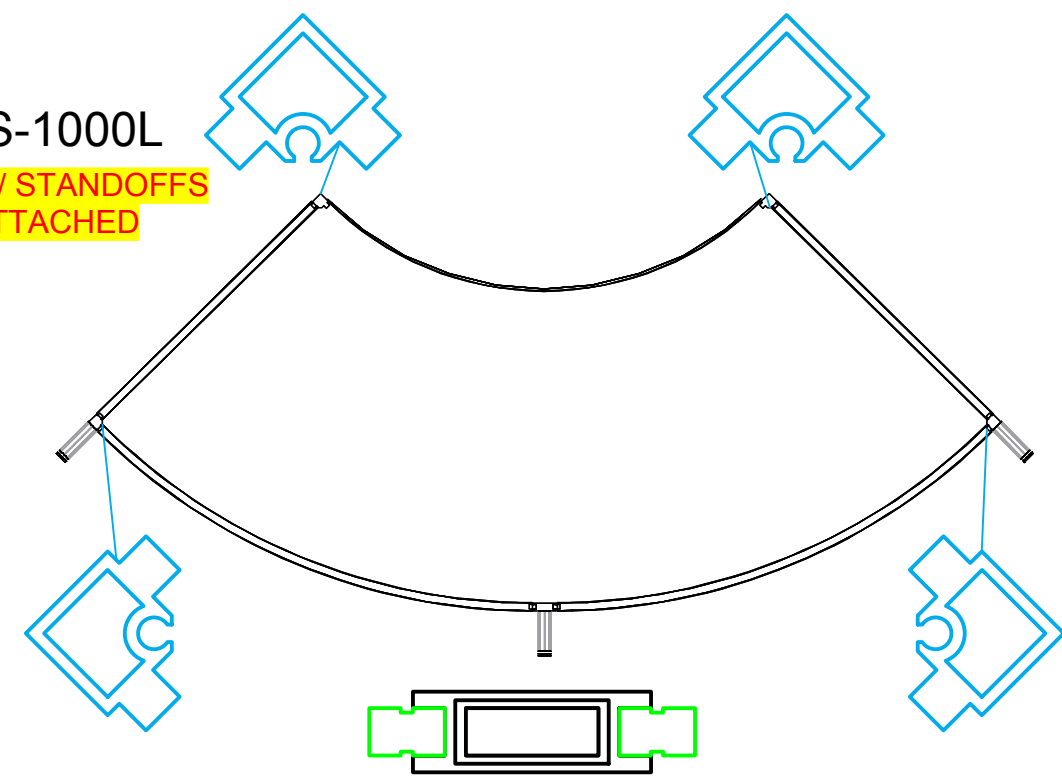
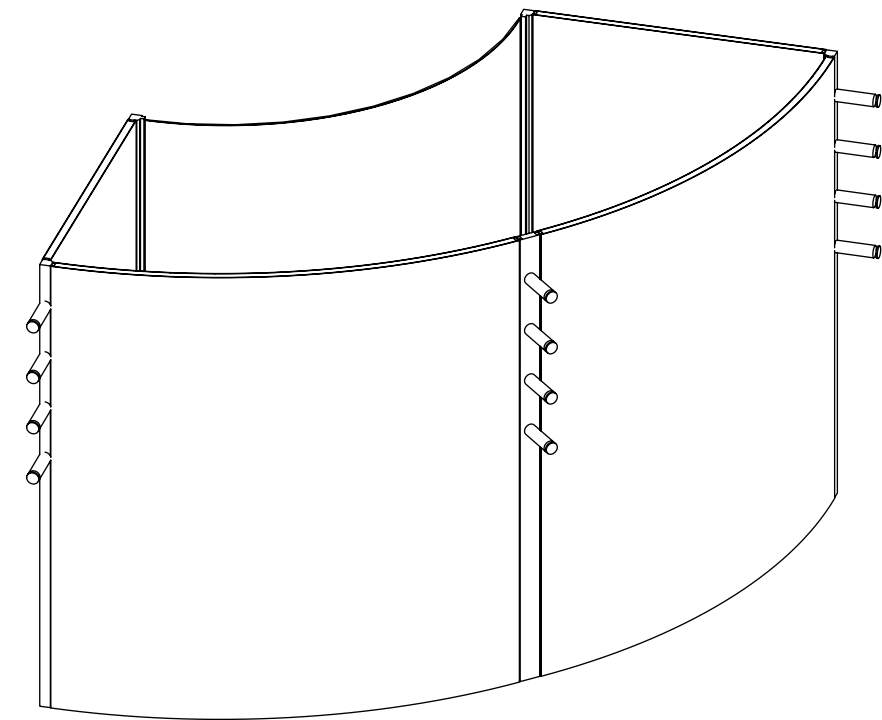
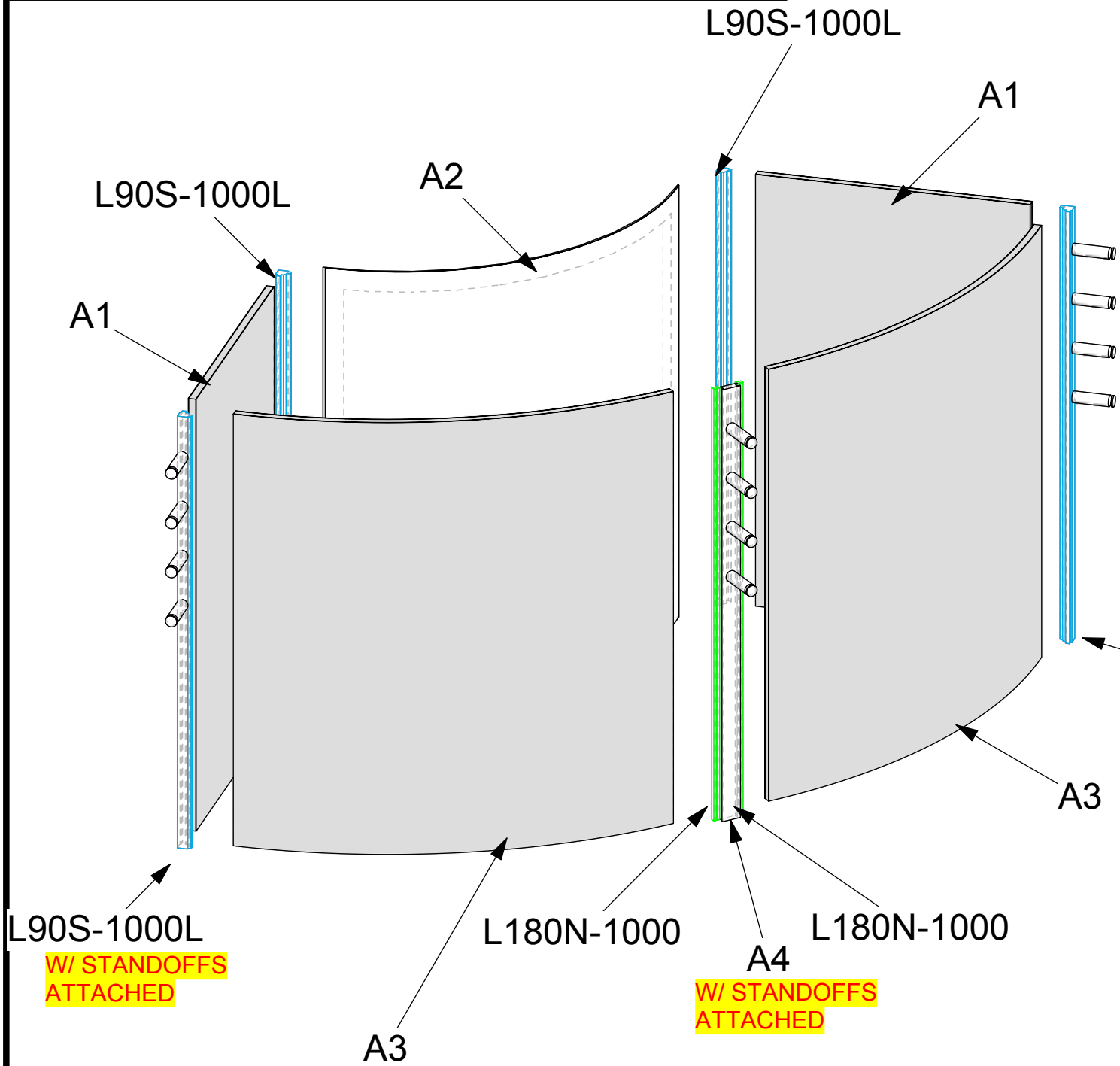

Legend for symbols:

- Phone Line / Fax
- Internet connection
- Outlet
- Main Drop (point of distrution)

Legend for components:

- L90S
- PH
- L180N

COUNTER

Title: SET-UP INSTRUCTIONS

Code	#	Description
VT-SNTRA	4	86.625" X 4" X 6MM ZUND CUT DSG GRAPHIC ON 6MM WHITE SINTRA

1. Redesign of this exhibit without approval by Origin may result in dangerous and unsafe structures. Origin disclaims any responsibility for redesigned exhibits it does not approve in writing.

2. Parts and components such as panels and extrusions are manufactured to metric sizing. Where ever possible sizes have been noted in feet and inches as well as in metric. Below is the imperial to metric sizing table as reference. "Nominal" refers to approximate size.

2400mm = (94 1/2")	☒ Phone Line / Fax
2100mm = (82 5/8")	☒ Internet connection
1800mm = (70 7/8")	☒ Outlet
1500mm = (59")	☒ Main Drop (point of distrution)
1200mm = (47 1/4")	
900mm = (35 1/2")	
600mm = (23 5/8")	
300mm = (11 7/8")	
- - - - - Wire running under carpet	

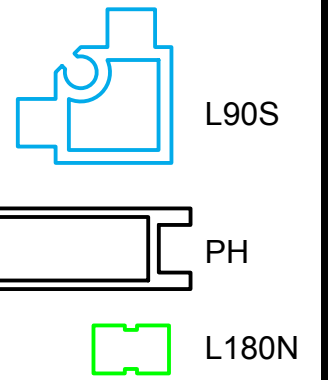
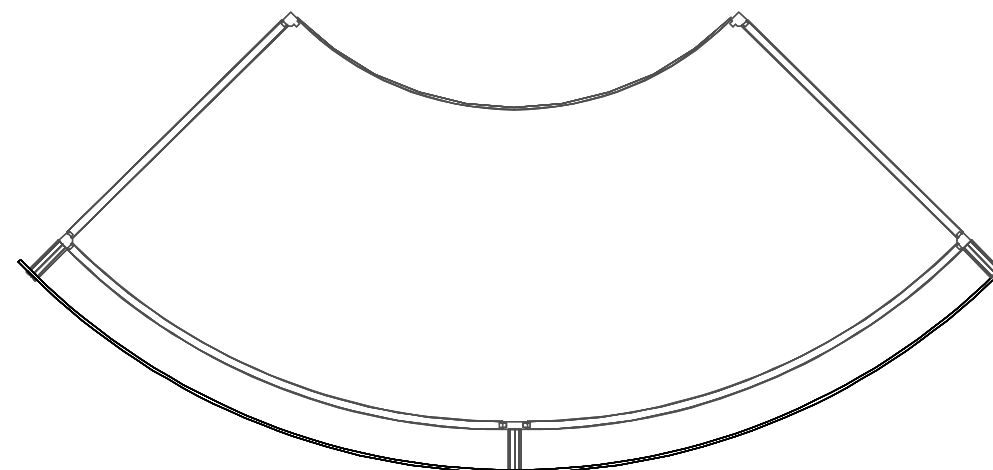
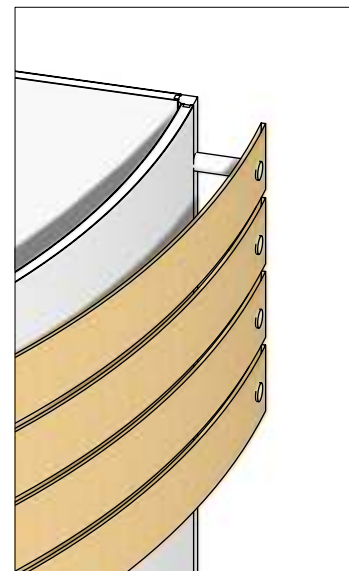
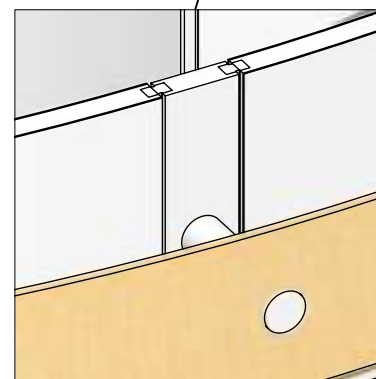
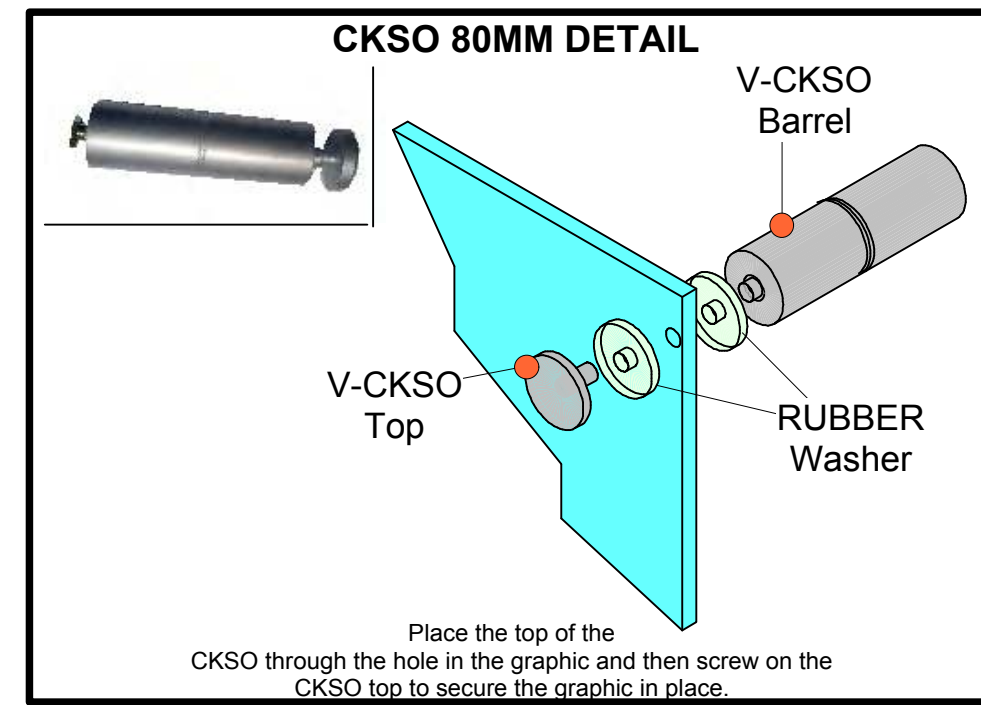
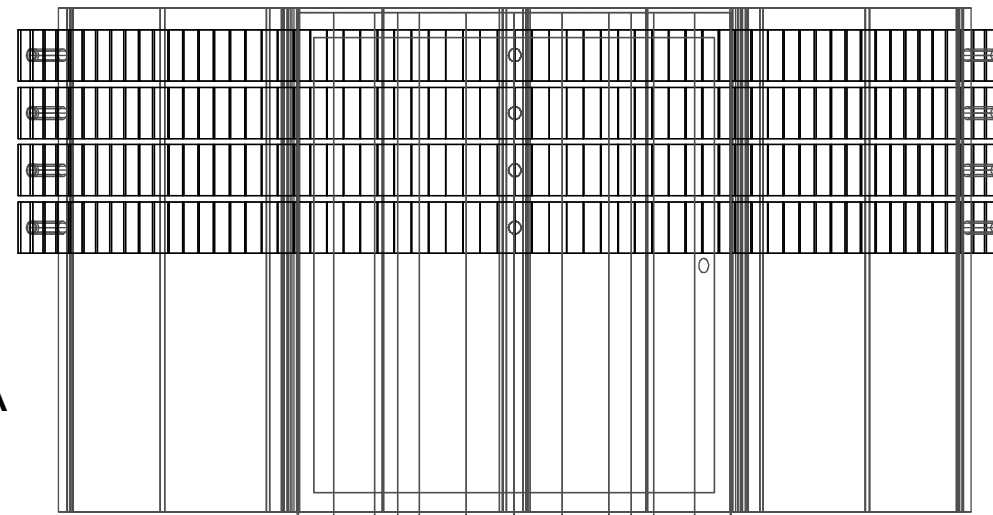
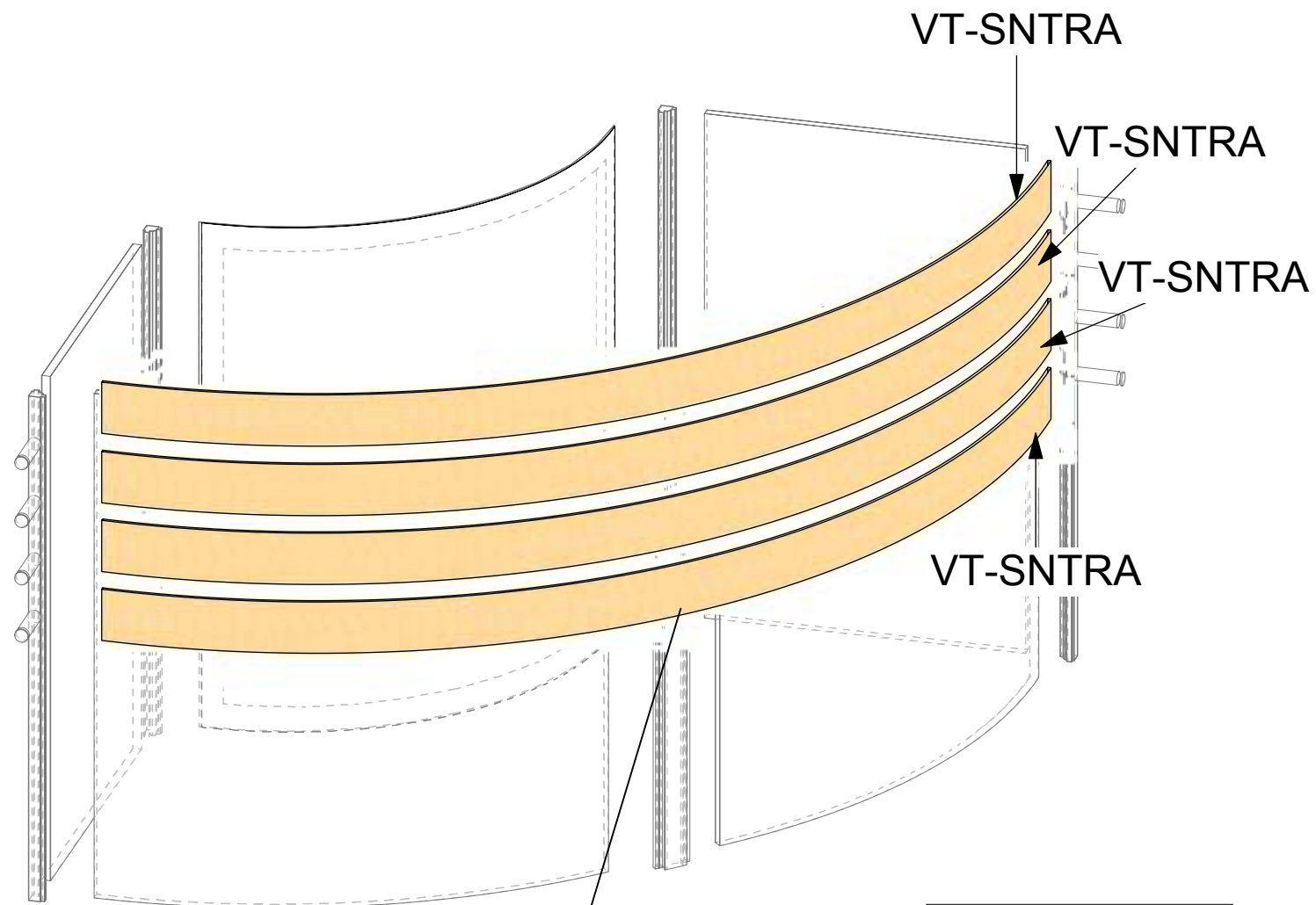

COUNTER

Title: SET-UP INSTRUCTIONS

Code	#	Description
C1	1	SHAPED 7' X 4' LAMINATE TOP WITH BLOCKS

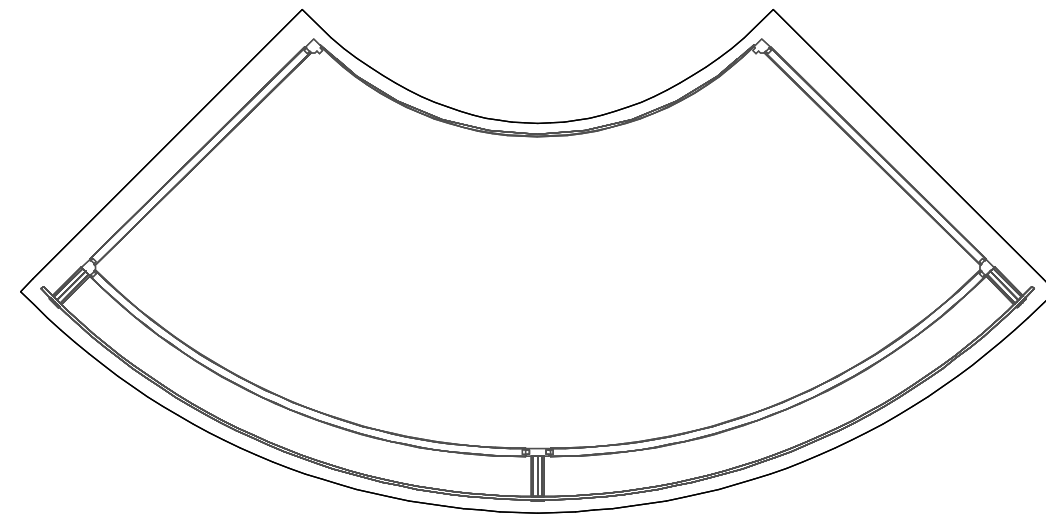
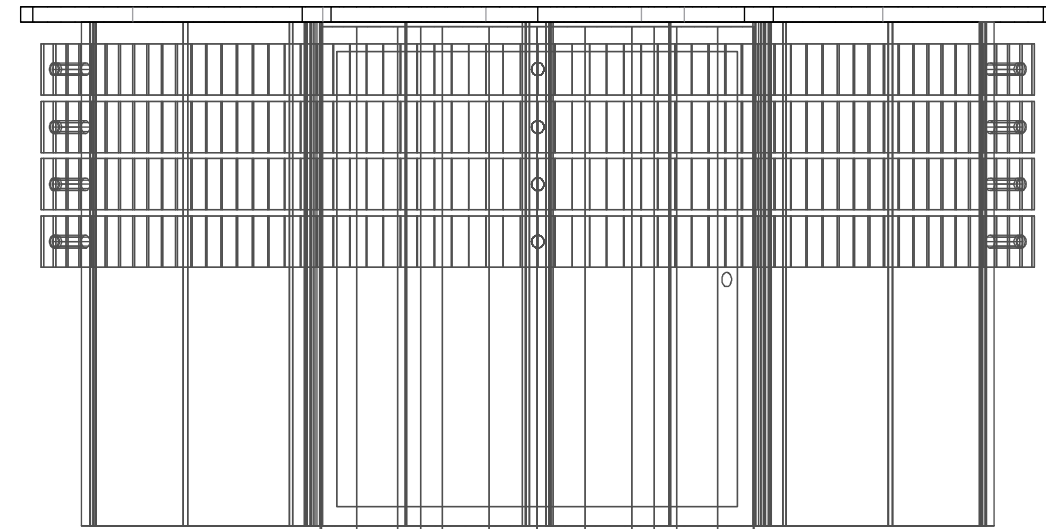
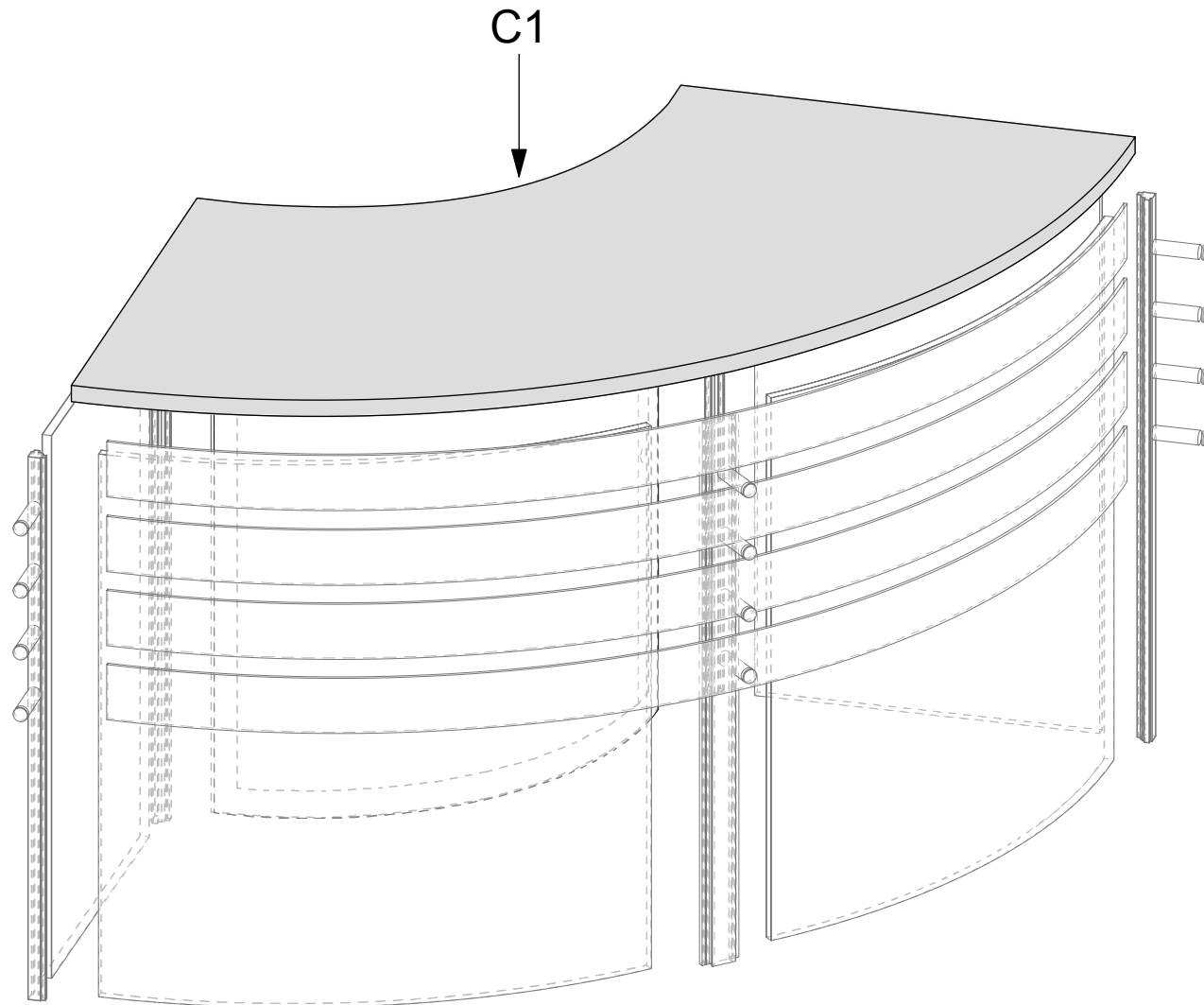

1. Redesign of this exhibit without approval by Origin may result in dangerous and unsafe structures. Origin disclaims any responsibility for redesigned exhibits it does not approve in writing.

2. Parts and components such as panels and extrusions are manufactured to metric sizing. Where ever possible sizes have been noted in feet and inches as well as in metric. Below is the imperial to metric sizing table as reference. "Nominal" refers to approximate size.

2400mm = (94 1/2")	☐ Phone Line / Fax
2100mm = (82 5/8")	⚡ Internet connection
1800mm = (70 7/8")	⚡ Outlet
1500mm = (59")	⚡ Main Drop (point of distrution)
1200mm = (47 1/4")	
900mm = (35 1/2")	
600mm = (23 5/8")	
300mm = (11 7/8")	
- - - - - Wire running under carpet	

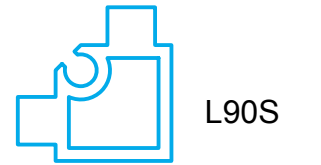

L90S



PH



L180N

COUNTER

Title: SET-UP INSTRUCTIONS

PACKING INSTRUCTIONS



2

1 KIT CFAB-K-05



CASE # 1

LEGEND		GREY FOAM FOLDED TO FILL EMPTY SPACES OR USED AS PROTECTION
		1/8" CARDBOARD SPACER (PUT IN BETWEEN EVERY PANEL)
		DIVIDER
		1/4" WHITE FOAM (USED AS PROTECTION DOOR PANELS W/ LOCKS)





