

Hybrid Pro Modular Kit 06

HP-K-06

Hybrid Pro™ Modular exhibits and counters are a perfect solution for the serious exhibitor. Exhibits feature heavy-duty aluminum extrusion frames and push-fit fabric graphics. Count on making an unforgettable impact with Hybrid Pro Modular exhibit kits, counters, and accessories.



features and benefits:

- Silver aluminum extrusion frame
- Single-sided SEG dye-sublimated push-fit fabric graphic
- Easy step-by-step instructions
- Kit includes frame, one fabric graphic panel, two counters, two medium monitor mounts, two 200 LED floodlights and three OCH2 molded cases
- Lifetime hardware warranty against manufacturer defects

dimensions:

Hardware

Assembled unit:
118.63" w x 94.75" h x 29.5" d
3013mm(w) x 2407mm(h) x 749mm(d)

Counters:
25.5" w x 39.2" h x 15.1" d approx.
648mm(w) x 996mm(h) x 384mm(d)

Counters (each) holds max weight
50 lbs / 22.68 kgs

Shipping

Shipping dimensions - ships in 3 cases:
3 OCH2 cases: 52" l x 29" w x 15" h
1321mm(l) x 737mm(w) x 381mm(h)

Approximate shipping weight (entire kit):
282 lbs / 128 kgs

Graphic

Refer to related graphic templates for more information

Visit: www.exhibitors-handbook.com/graphic-templates

additional information:

Fabric material:
Dye-sublimated fabric

Tabletop color options:



silver black mahogany natural

Lights Included:
Lumina 200 LED floodlight, straight arm and adjustable head, black finish, 19.5" from end to end

Medium monitor bracket holds 32"-55" LCD, maximum weight: 50 lbs / 36.29kgs

We are continually improving and modifying our product range and reserve the right to vary the specifications without prior notice. All dimensions and weights quoted are approximate and we accept no responsibility for variance. E&OE. See Graphic Templates for graphic bleed specifications.

R-HP-K-06

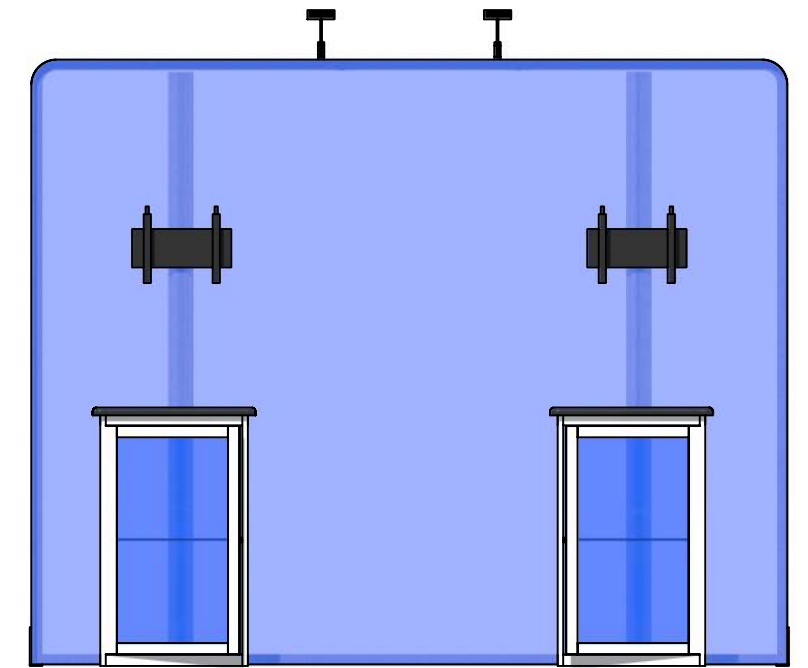
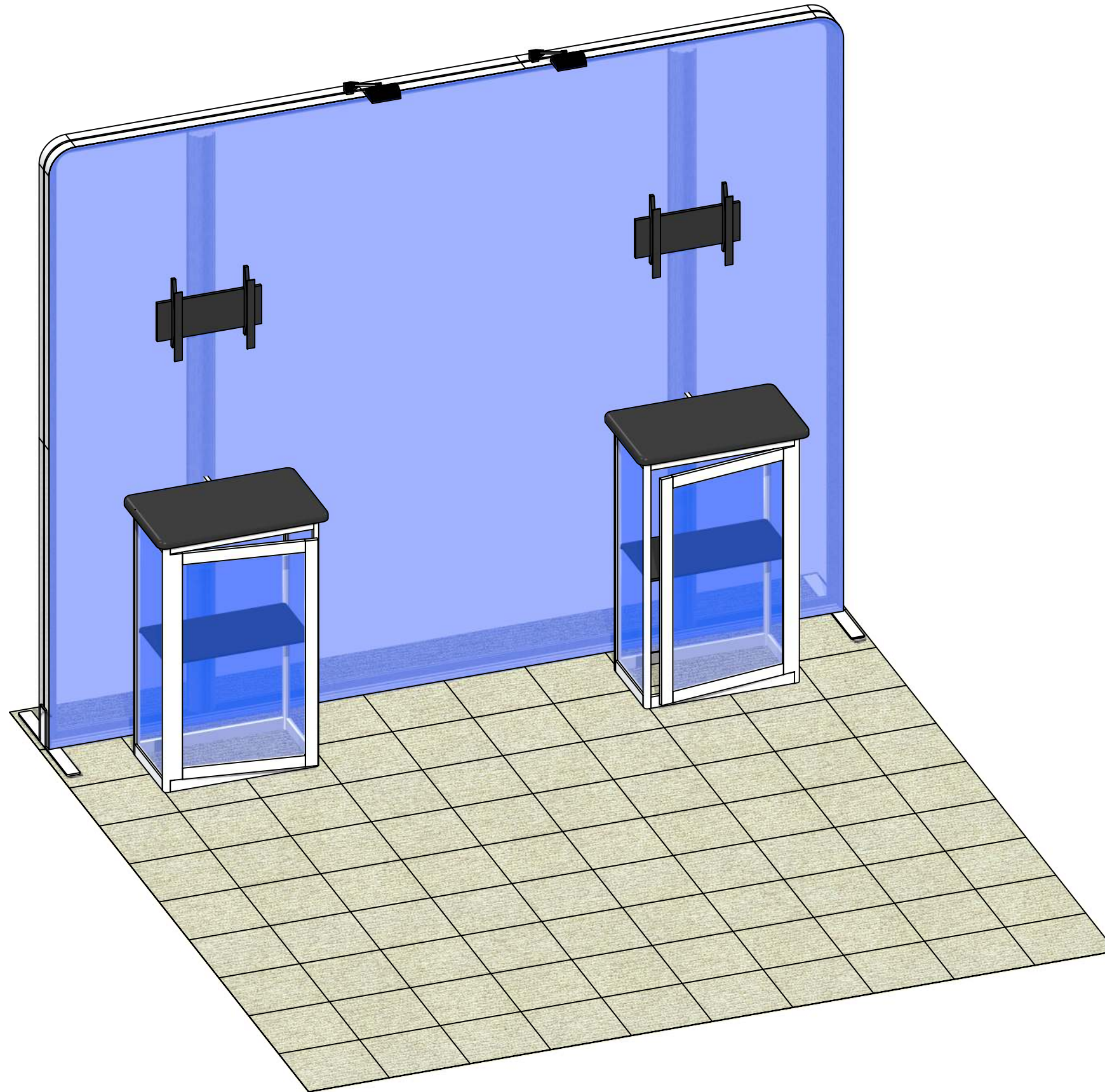

Code	#	Description
SW-FOOT	2	SMARTWALL SUPPORT FOOT
R10	4	1200MM (47.24") PHFC4 EXTRUSION WITH MITRE CUT 1 END FOR CB9 ONE END-IB2 HOLES ONE END
R45	4	1100MM (43.31") PHFC4 EXTRUSION WITH IB2 LOCK HOLES ONE SIDE-LOCK ONE SIDE
CB9	2	CB9 CORNER BRACKET
IB2	6	INLINE BRACKET CONNECTOR
CB9R100	2	100MM ROUND PHFC4 CORNER BRACKET
R46	2	600MM (23.62") PHFC4 EXTRUSION WITH IB2 HOLES BOTH ENDS
GRAPHIC A	1	94 1/2" (H) X 118 1/8" (W) SINGLE SIDED DYESUB GRAPHIC W/ FCE-2 (SEG) ON PERIMETER W/ CB100R CORNE
R12	4	1155MM (45.47") 100MM PM4R8 ROUND EXTRUSION WITH LOCKS 1 END WITH PH2 STOP AT 155MM
R14	2	300MM (11.81") PM4D CONNECTOR WITH TENSION GLIDES
LEDL10S	2	LED SPOTLIGHT,3M,UL PLUG W/TRANSFORMER SILVER
LN-100	2	JOINING BAR
EXT-M-MB	2	MEDIUM MONITOR BRACKET FOR MONITORS 32"-55"
V-CU-CAB-01-S	2	292MM X 553 (11 1/2" X 21 3/4") INTERNAL SHELF FOR V-CU-CAB-01
R50	8	280MM (11") PH WITH SLIDE LOCK AT BOTH ENDS
GRAPHIC D	4	922MM X 292MM (36 5/16" X 11 1/2") SIDE SINTRA/FOAMEX
R53	2	581MM X 1000MM (22 7/8" X 39 3/8") FRONT FRAME W/GFX INFILL W/SLIT
R52	2	581MM X 1000MM (22 7/8" X 39 3/8") CABINET DOOR W/GFX INFILL
V-SS1	8	SHELF SUPPORT
V-CW-CT-01	2	384MM X 646MM (15 1/8" X 25 7/16") HYBRID RECTANGLE TOP
R48	2	100MM (3.94") PH1 EXTRUSION WITH LOCKS 2 ENDS

BOM

R-HP-K-06

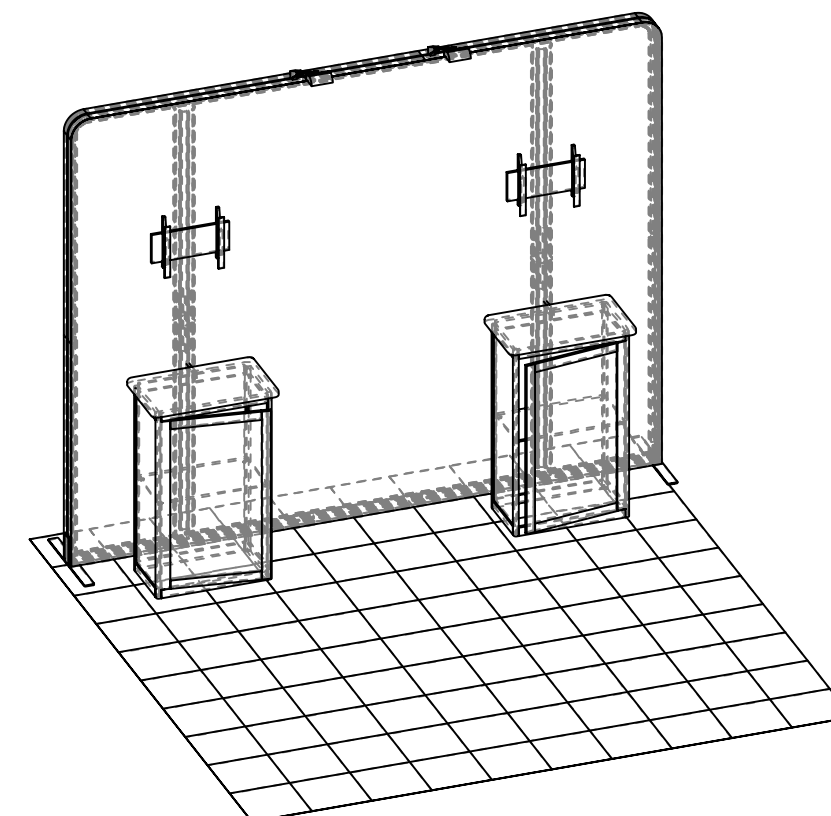
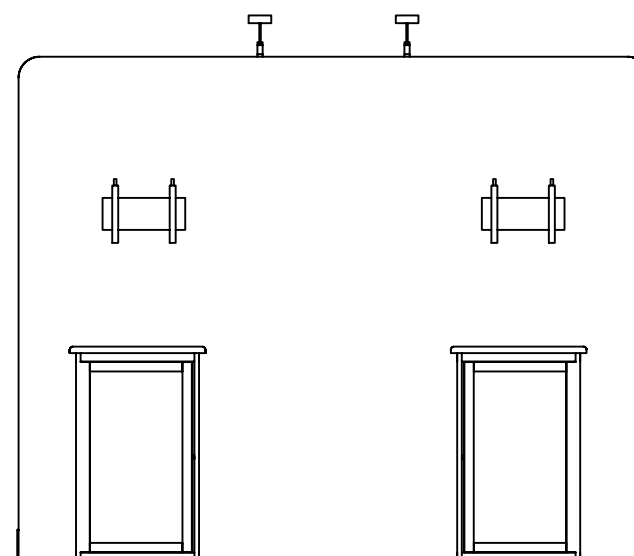
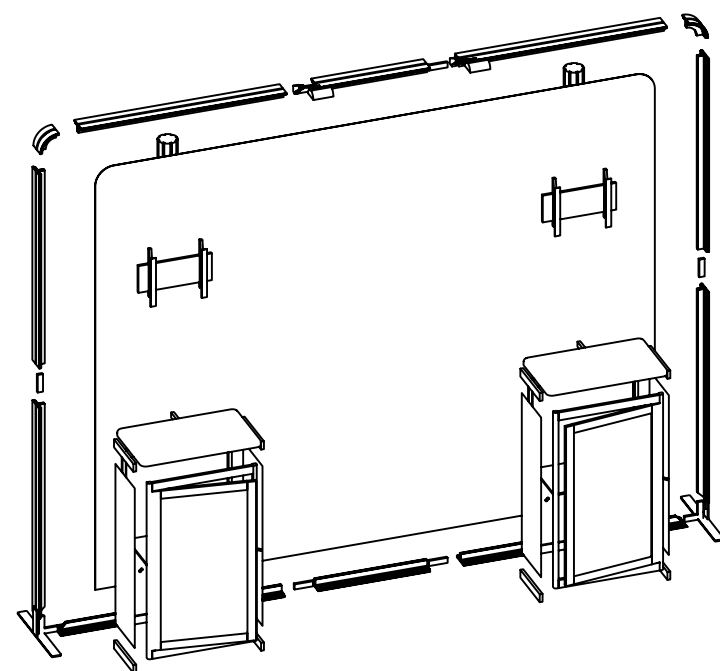
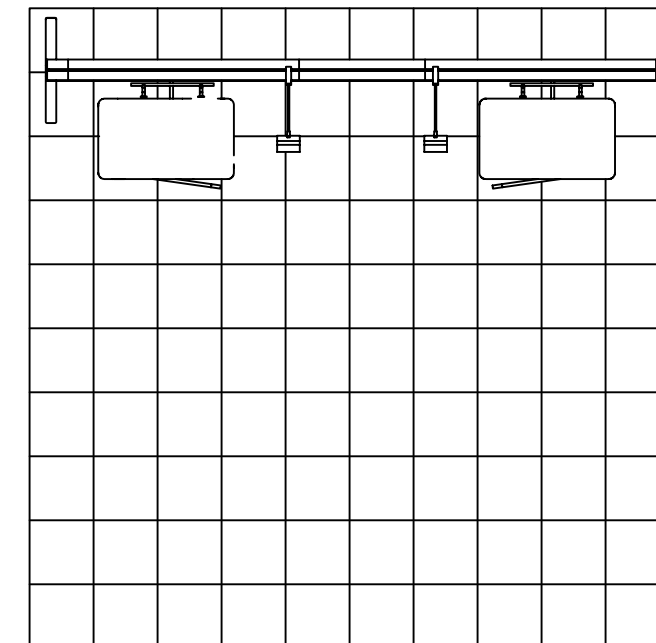

1. Redesign of this exhibit without approval by manufacturer may result in dangerous and unsafe structures. Manufacturer disclaims any responsibility for redesigned exhibits it does not approve in writing.

2. Parts and components such as panels and extrusions are manufactured to metric sizing. Where ever possible sizes have been noted in feet and inches as well as in metric. Below is the imperial to metric sizing table as reference. "Nominal" refers to approximate size.

- | | |
|--------------------|-----------------------------------|
| 2400mm = (94 1/2") | ☒ Phone Line / Fax |
| 2100mm = (82 5/8") | ☒ Internet connection |
| 1800mm = (70 7/8") | ☒ Outlet |
| 1500mm = (59") | ☒ Main Drop (point of distrution) |
| 1200mm = (47 1/4") | |
| 900mm = (35 1/2") | |
| 600mm = (23 5/8") | |
| 300mm = (11 7/8") | |
- Wire running under carpet

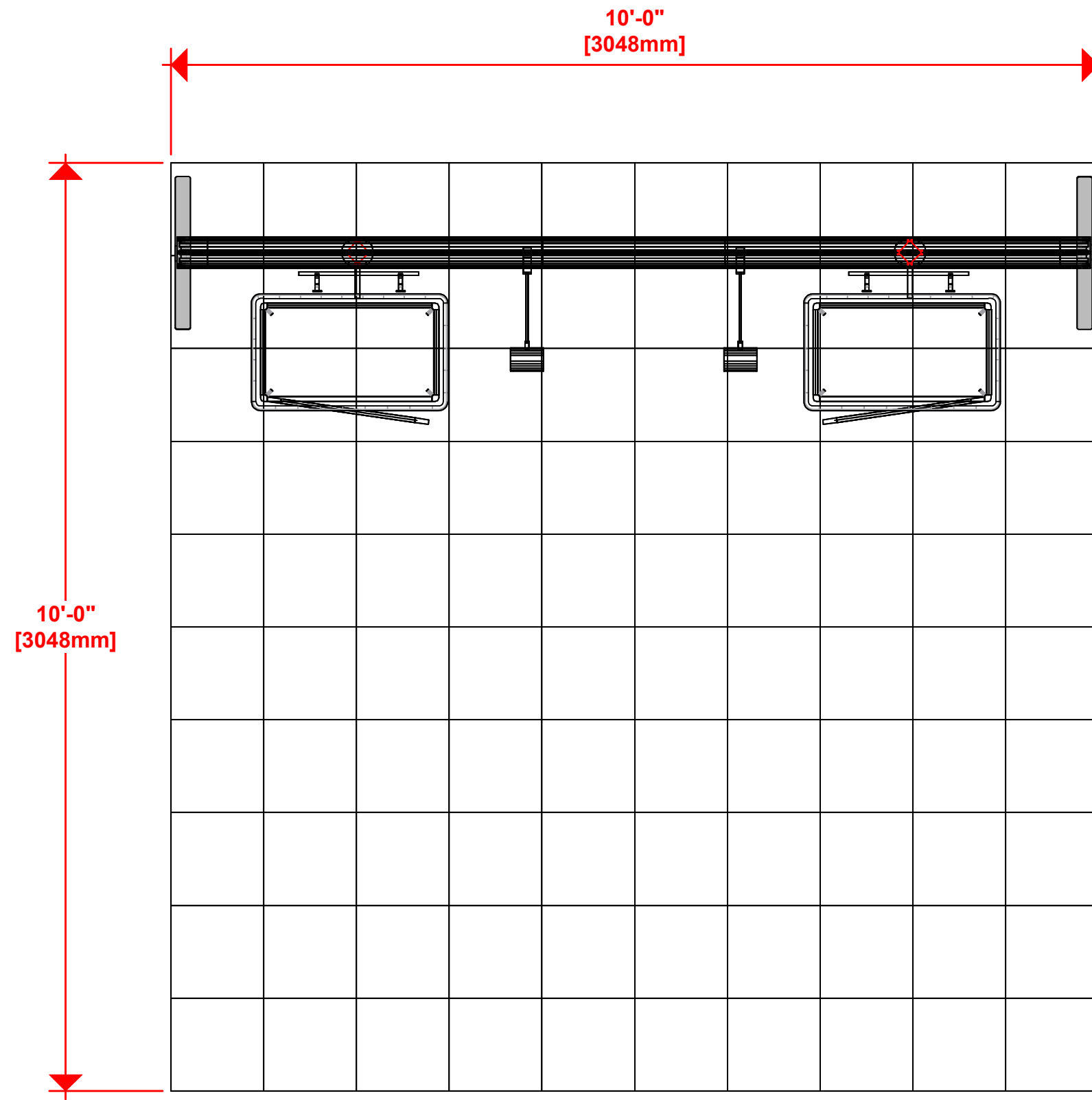

(4) LV1 LIGHTS = 50W PER STICK

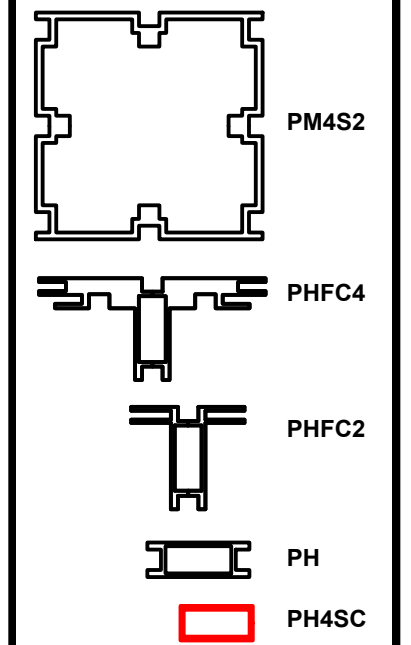

HYBRID PRO RENTAL KIT

Title: SET-UP INSTRUCTIONS

EP

Code	#	Description
GRAPHIC A	1	94 1/2" (H) X 118 1/8" (W) SINGLE SIDED DYESUB GRAPHIC W/ FCE-2 (SEG) ON
EXT-M-MB	2	MEDIUM MONITOR BRACKET FOR MONITORS 32"-55"
R48	2	100MM (3.94") PH1 EXTRUSION WITH LOCKS 2 ENDS

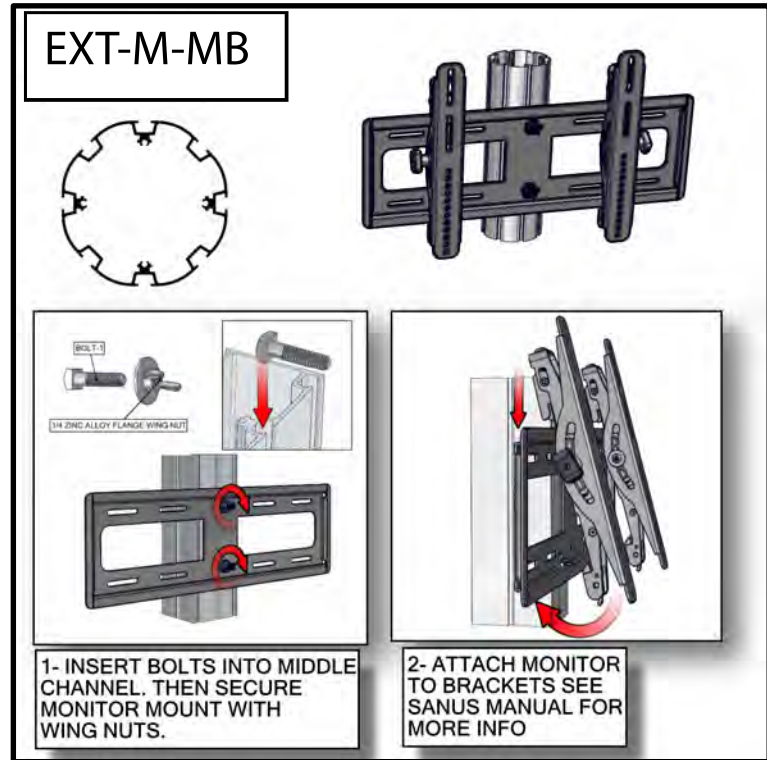
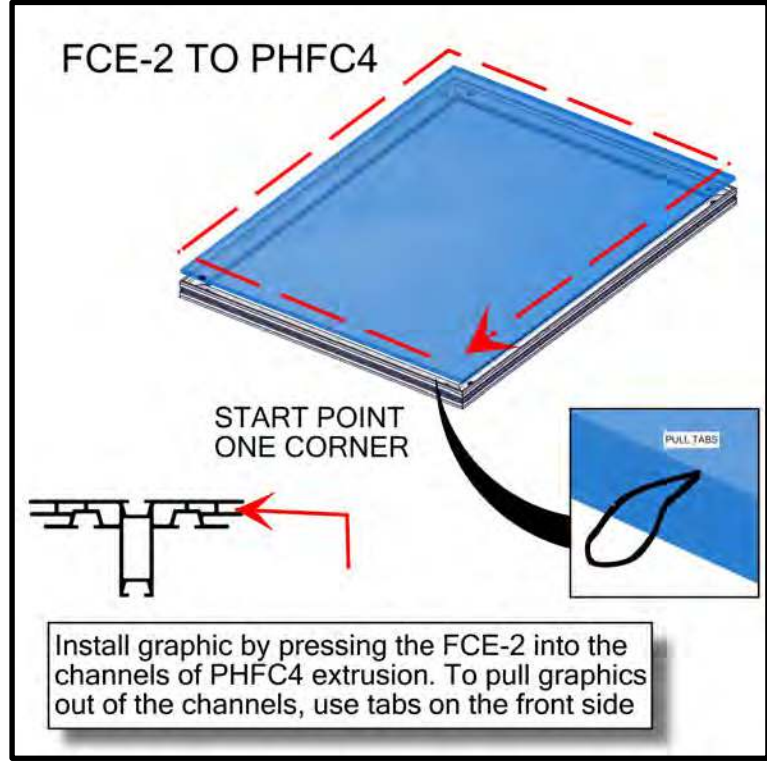
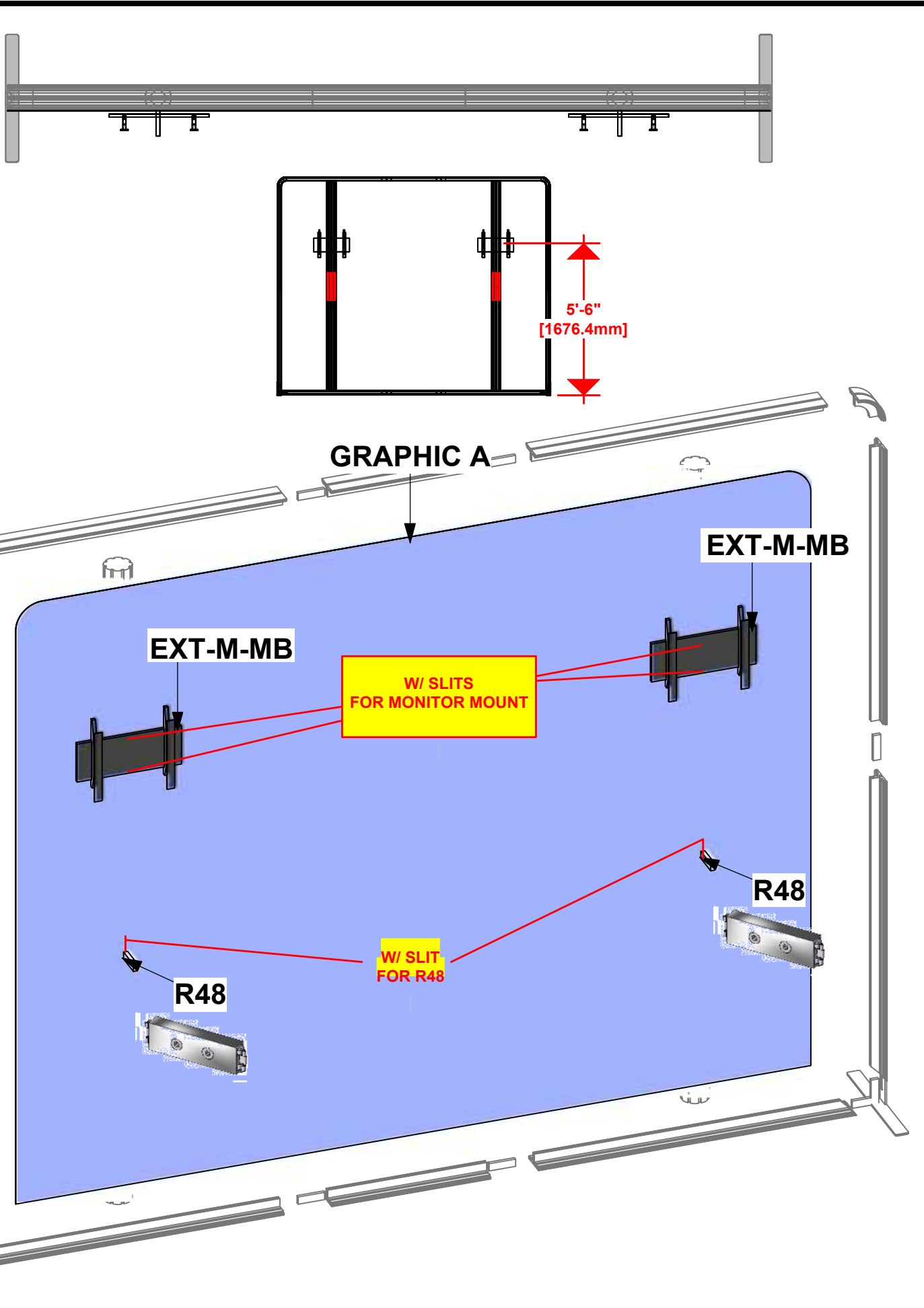

1. Redesign of this exhibit without approval by manufacturer may result in dangerous and unsafe structures. Manufacturer disclaims any responsibility for redesigned exhibits it does not approve in writing.

2. Parts and components such as panels and extrusions are manufactured to metric sizing. Where ever possible sizes have been noted in feet and inches as well as in metric. Below is the imperial to metric sizing table as reference. "Nominal" refers to approximate size.

2400mm = (94 1/2")	Phone Line / Fax
2100mm = (82 5/8")	Internet connection
1800mm = (70 7/8")	Outlet
1500mm = (59")	Main Drop (point of distrution)
1200mm = (47 1/4")	
900mm = (35 1/2")	
600mm = (23 5/8")	
300mm = (11 7/8")	

--- Wire running under carpet

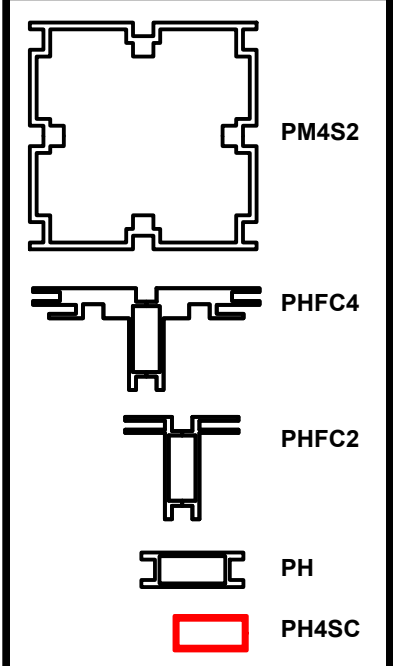

HYBRID PRO RENTAL KIT

Title: SET-UP INSTRUCTIONS

Code	#	Description
LEDL10S	2	LED SPOTLIGHT,3M,UL PLUG W/TRANSFORMER SILVER

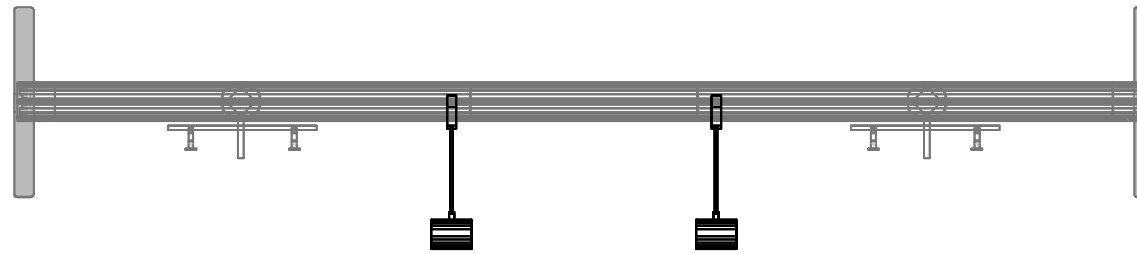
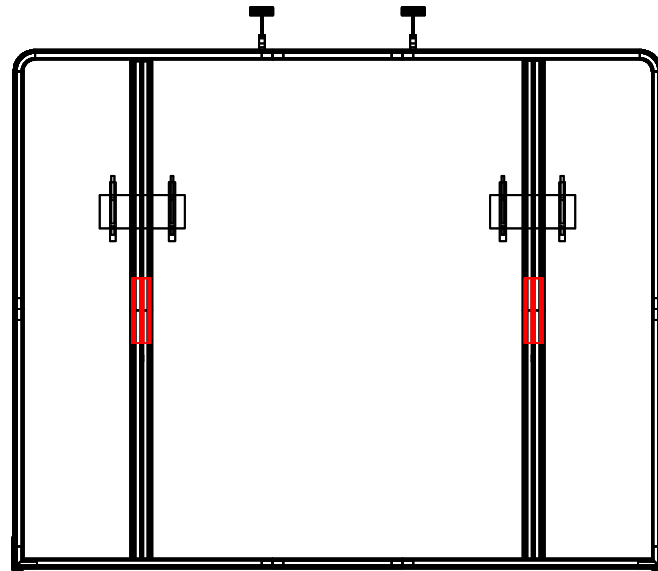

1. Redesign of this exhibit without approval by manufacturer may result in dangerous and unsafe structures. Manufacturer disclaims any responsibility for redesigned exhibits it does not approve in writing.

2. Parts and components such as panels and extrusions are manufactured to metric sizing. Where ever possible sizes have been noted in feet and inches as well as in metric. Below is the imperial to metric sizing table as reference. "Nominal" refers to approximate size.

2400mm = (94 1/2")	Phone Line / Fax
2100mm = (82 5/8")	Internet connection
1800mm = (70 7/8")	Outlet
1500mm = (59")	Main Drop (point of distrution)
1200mm = (47 1/4")	
900mm = (35 1/2")	
600mm = (23 5/8")	
300mm = (11 7/8")	

--- Wire running under carpet

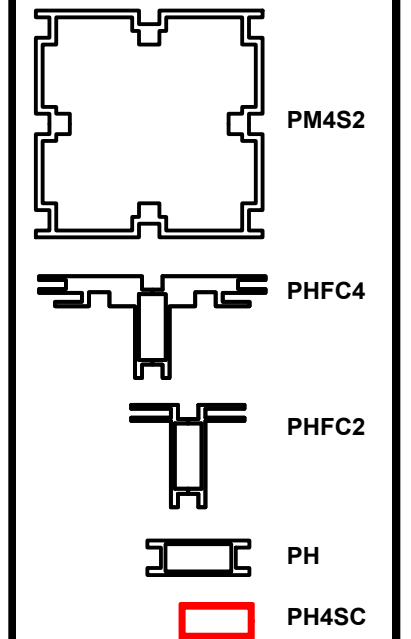
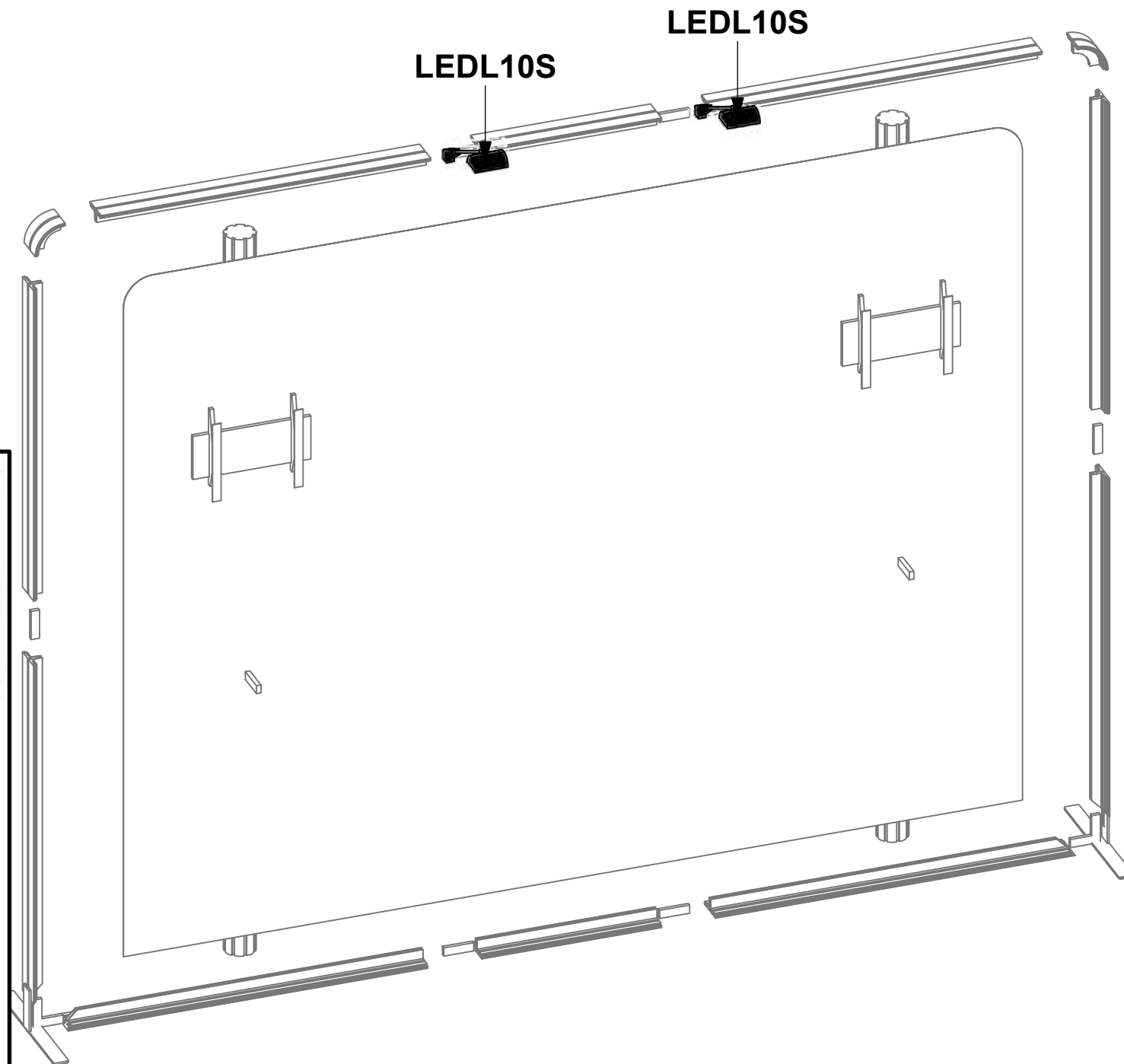

LIGHT



1- Slide light clip onto the LIGHT.
 2-Then slide the LIGHT into the channel at an angle and then gently lower down.

HYBRID PRO RENTAL KIT

Title: SET-UP INSTRUCTIONS

Code	#	Description
R50	4	280MM (11") PH WITH SLIDE LOCK AT BOTH ENDS
R53	2	581MM X 1000MM (22 7/8" X 39 3/8") FRONT FRAME W/GFX IN
R52	2	581MM X 1000MM (22 7/8" X 39 3/8") CABINET DOOR W/GFX IN

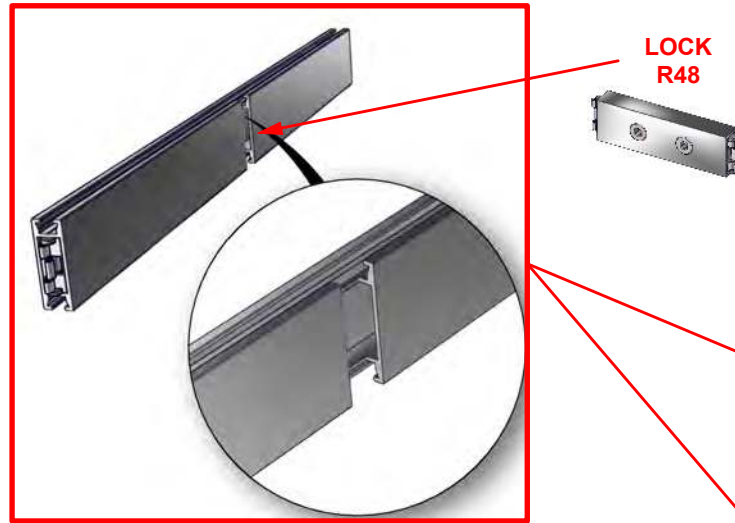
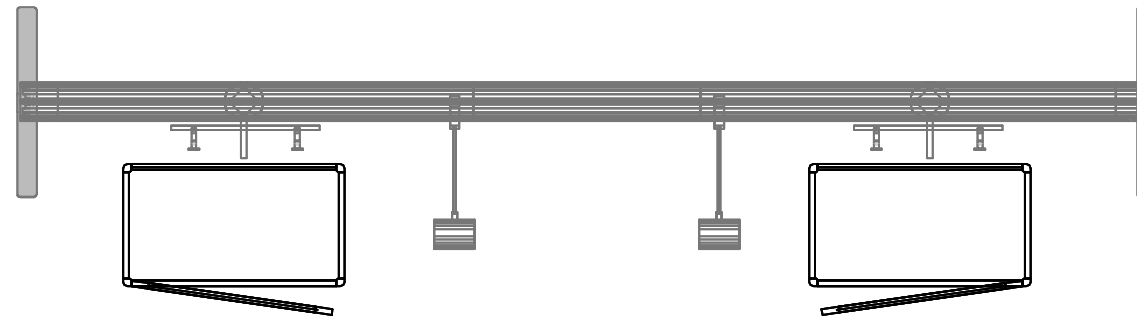

LOCK
R48

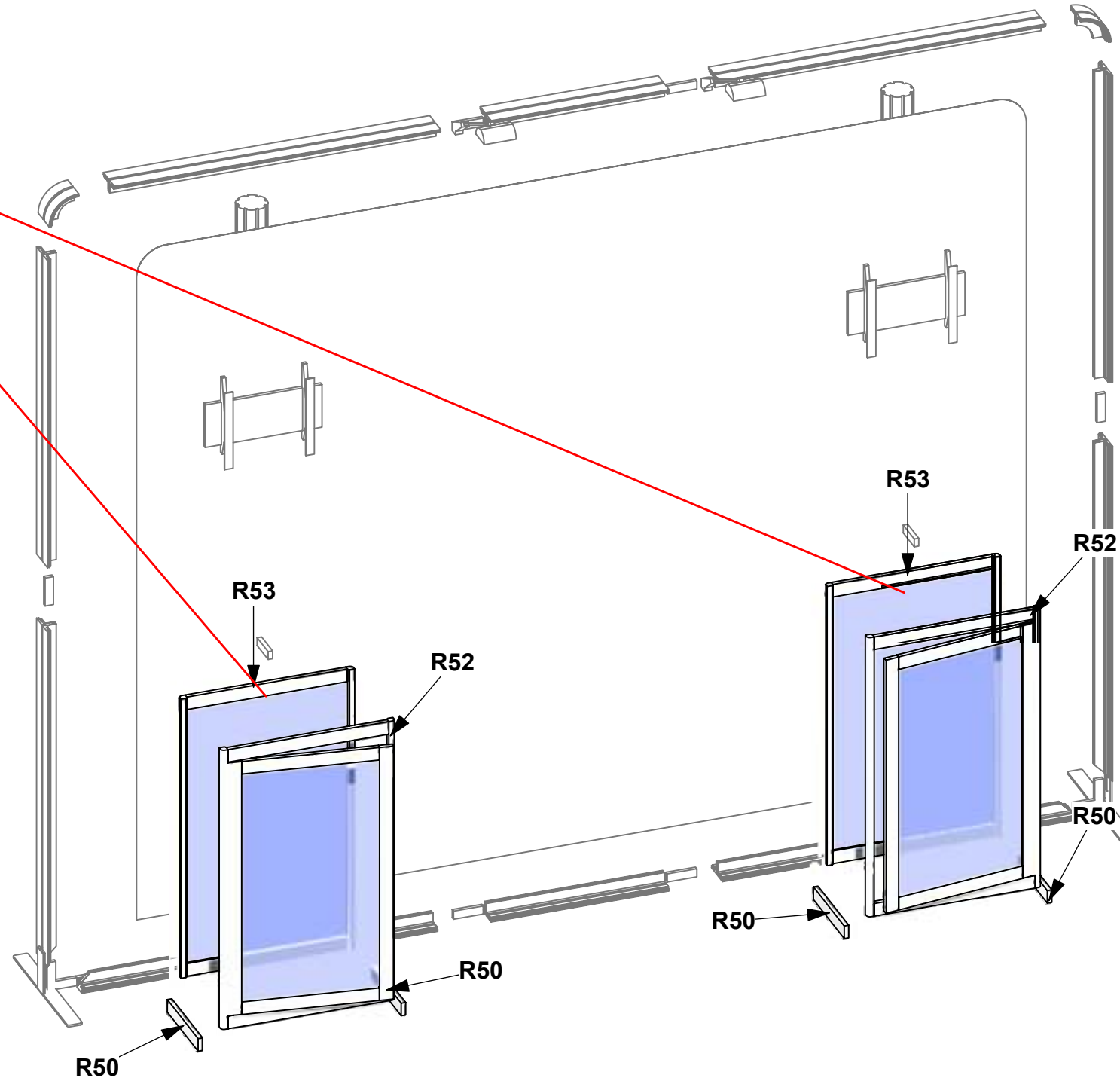

WARNING!
Locks should ONLY
be turned a half
(or quarter) turn so
as not to STRIP the locks by
over torqueing them

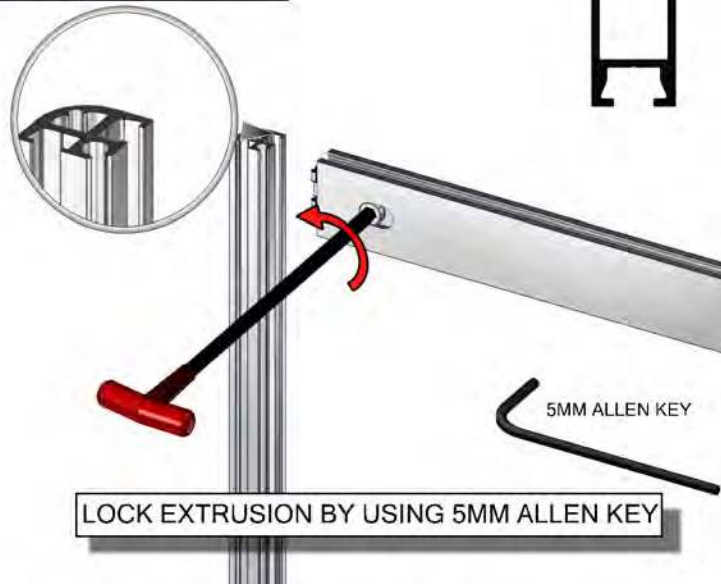

5MM ALLEN KEY

LOCK EXTRUSION BY USING 5MM ALLEN KEY

1. Redesign of this exhibit without approval by manufacturer may result in dangerous and unsafe structures. Manufacturer disclaims any responsibility for redesigned exhibits it does not approve in writing.

2. Parts and components such as panels and extrusions are manufactured to metric sizing. Where ever possible sizes have been noted in feet and inches as well as in metric. Below is the imperial to metric sizing table as reference. *Nominal" refers to approximate size.

2400mm = (94 1/2")	Phone Line / Fax
2100mm = (82 5/8")	Internet connection
1800mm = (70 7/8")	Outlet
1500mm = (59")	Main Drop (point of distrution)
1200mm = (47 1/4")	
900mm = (35 1/2")	
600mm = (23 5/8")	
300mm = (11 7/8")	

--- Wire running under carpet

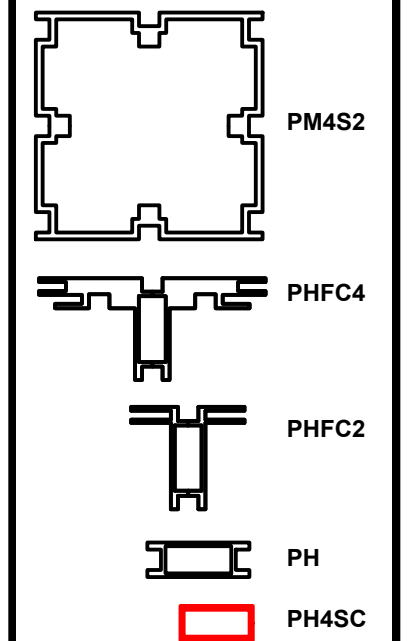

HYBRID PRO RENTAL KIT

Title: SET-UP INSTRUCTIONS

Code	#	Description
INT SHELF	1	292MM X 553 (11 1/2" X 21 3/4") INTERNAL SHELF FOR
R50	4	280MM (11") PH WITH SLIDE LOCK AT BOTH ENDS
GRAPHIC D	3	922MM X 292MM (36 5/16" X 11 1/2") SIDE SINTRA/FOA
V-SS1	8	SHELF SUPPORT
V-CU-CAB-01-	1	292MM X 553 (11 1/2" X 21 3/4") INTERNAL SHELF FOR

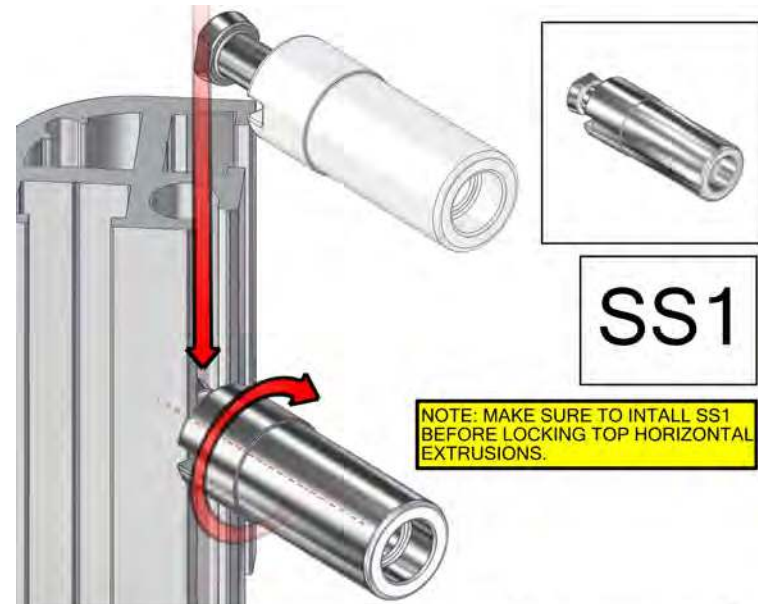

SS1

NOTE: MAKE SURE TO INTALL SS1 BEFORE LOCKING TOP HORIZONTAL EXTRUSIONS.

Slide the SS1 into the round SS1 channel to the desired height. Then turn clockwise to tighten the SS1 into place.

WARNING!
Locks should ONLY be turned a half (or quarter) turn so as not to STRIP the locks by over torqueing them

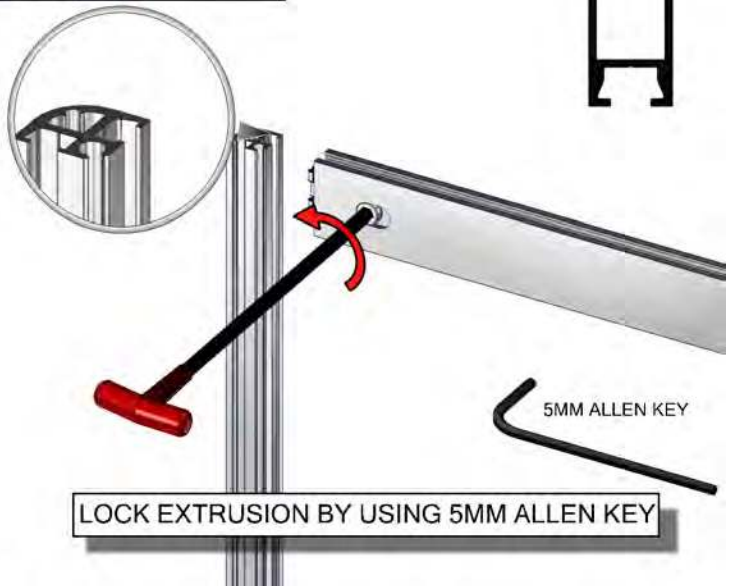

5MM ALLEN KEY

LOCK EXTRUSION BY USING 5MM ALLEN KEY

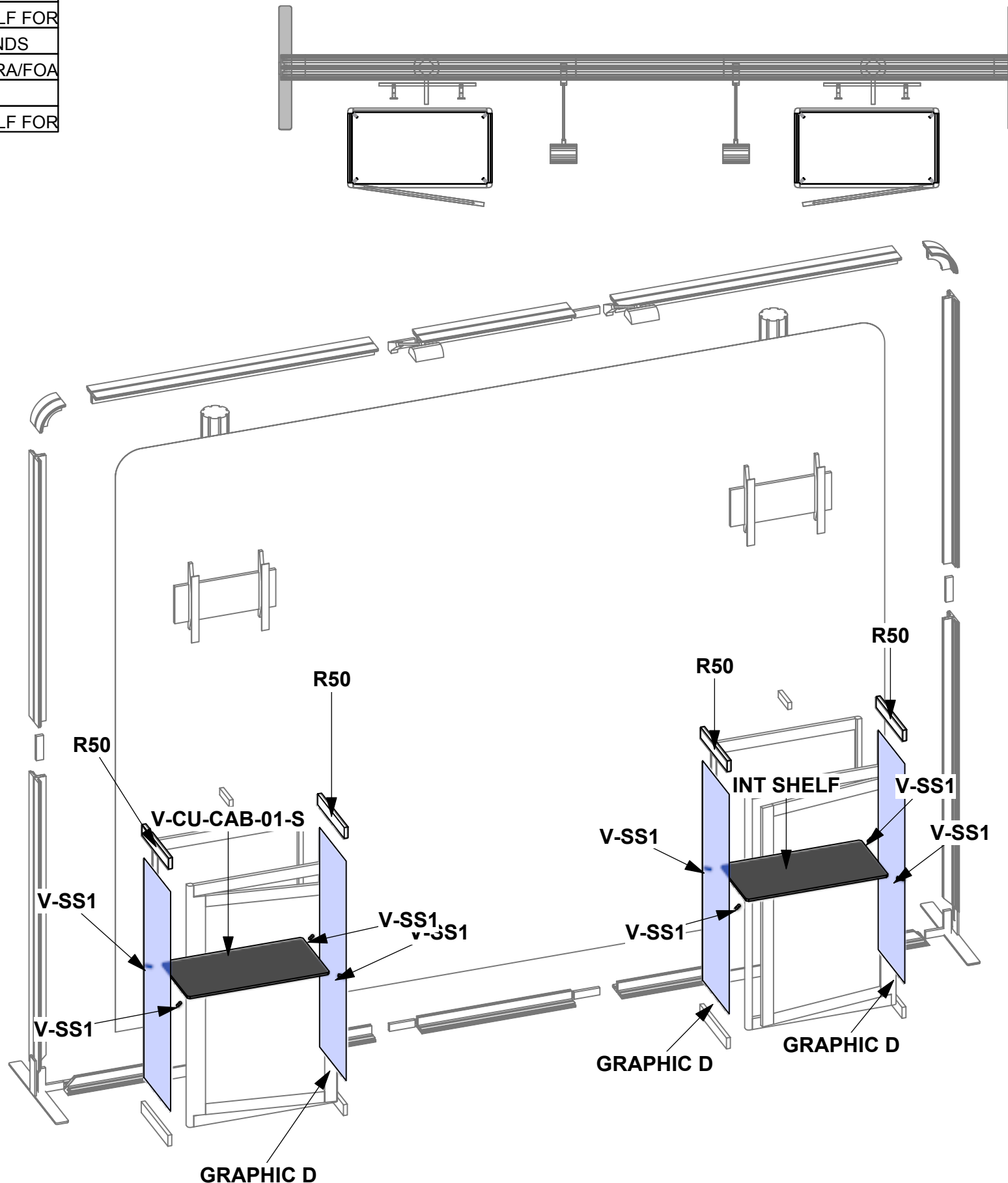

1. Redesign of this exhibit without approval by manufacturer may result in dangerous and unsafe structures. Manufacturer disclaims any responsibility for redesigned exhibits it does not approve in writing.

2. Parts and components such as panels and extrusions are manufactured to metric sizing. Where ever possible sizes have been noted in feet and inches as well as in metric. Below is the imperial to metric sizing table as reference. *Nominal" refers to approximate size.

2400mm = (94 1/2")	Phone Line / Fax
2100mm = (82 5/8")	Internet connection
1800mm = (70 7/8")	Outlet
1500mm = (59")	Main Drop (point of distrution)
1200mm = (47 1/4")	
900mm = (35 1/2")	
600mm = (23 5/8")	
300mm = (11 7/8")	

--- Wire running under carpet

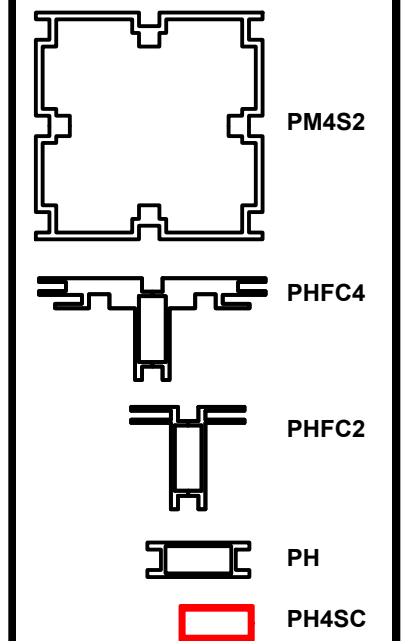

HYBRID PRO RENTAL KIT

Title: SET-UP INSTRUCTIONS

Code	#	Description
V-CW-CT-01	2	384MM X 646MM (15 1/8" X 25 7/16") HYBRID RECTANGLE TOP

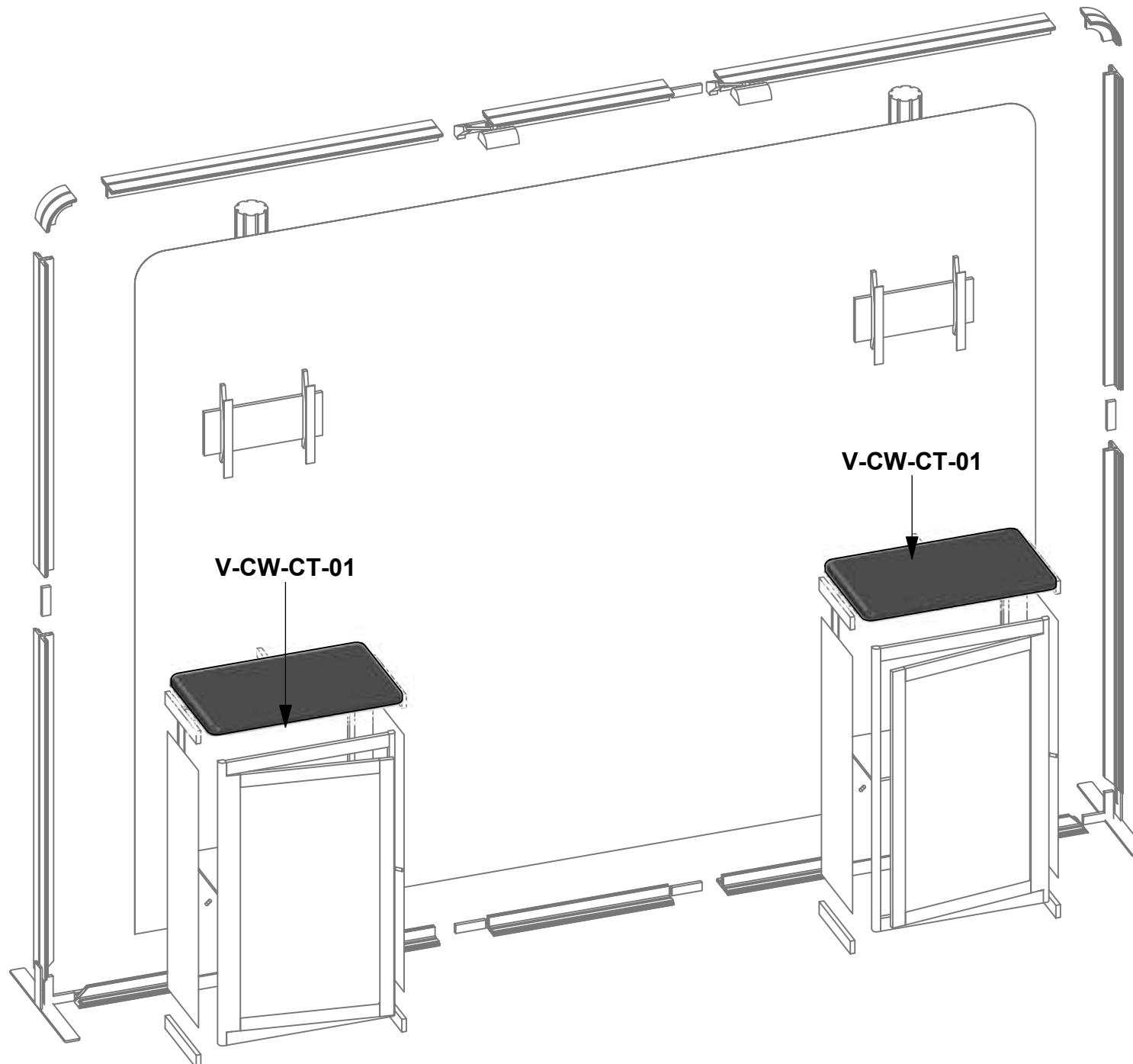
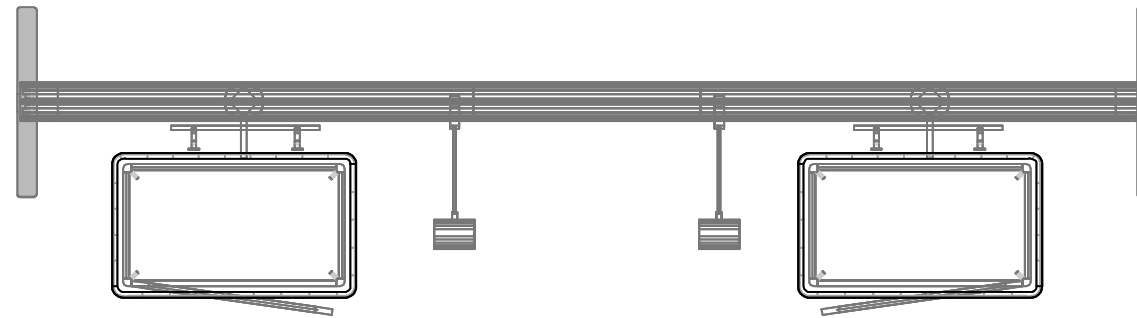

1. Redesign of this exhibit without approval by manufacturer may result in dangerous and unsafe structures. Manufacturer disclaims any responsibility for redesigned exhibits it does not approve in writing.

2. Parts and components such as panels and extrusions are manufactured to metric sizing. Where ever possible sizes have been noted in feet and inches as well as in metric. Below is the imperial to metric sizing table as reference. *Nominal* refers to approximate size.

- | | |
|--------------------|-----------------------------------|
| 2400mm = (94 1/2") | ☒ Phone Line / Fax |
| 2100mm = (82 5/8") | ☒ Internet connection |
| 1800mm = (70 7/8") | ☒ Outlet |
| 1500mm = (59") | ☒ Main Drop (point of distrution) |
| 1200mm = (47 1/4") | |
| 900mm = (35 1/2") | |
| 600mm = (23 5/8") | |
| 300mm = (11 7/8") | |
- Wire running under carpet

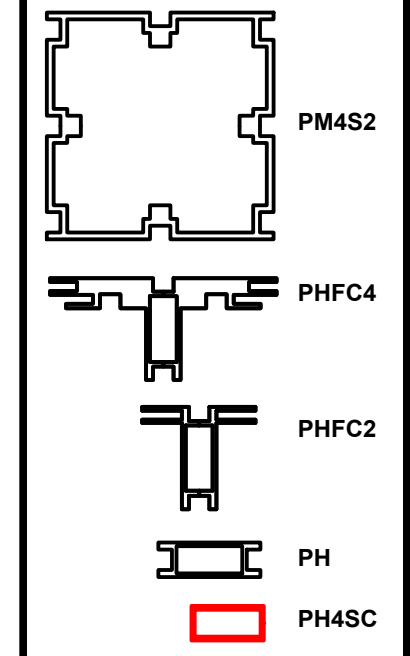

HYBRID PRO RENTAL KIT

Title: SET-UP INSTRUCTIONS

PACKING INSTRUCTIONS



1 (2) MEDIUM MONITOR BRACKETS



2 (4) R10, (4) R45, (2) R46



3 (4) R12, (2) R14

CASE # 1

LEGEND		GREY FOAM FOLDED TO FILL EMPTY SPACES OR USED AS PROTECTION
		1/8" CARDBOARD SPACER (PUT IN BETWEEN EVERY PANEL)
		DIVIDER
		1/4" WHITE FOAM (USED AS PROTECTION DOOR PANELS W/ LOCKS)
		PROTECTION DOOR PANELS W/ LOCKS

INTERNAL DIMS 48.25"L X 24"W X 14"H
EXTERNAL DIMS 51.5"L X 29"W X 14.5"H



1 (1) STEAMER, (2) LED L10 LIGHTS
(2) SW-FOOT



2 (1) R53 (4) R50



3 (2) SINTRA GRAPHICS



4 (1) BLACK SHELF, (1) V-CW-CT-01



5 (1) R52

CASE # 2

LEGEND	
	GREY FOAM FOLDED TO FILL EMPTY SPACES OR USED AS PROTECTION
	1/8" CARDBOARD SPACER (PUT IN BETWEEN EVERY PANEL)
	DIVIDER
	1/4" WHITE FOAM (USED AS PROTECTION DOOR PANELS W/ LOCKS)

INTERNAL DIMS 48.25"L X 24"W X 14"H
EXTERNAL DIMS 51.5"L X 29"W X 14.5"H



1 (4) R50, (1) R53



2 (2) SINTRA GRAPHICS



3 (1) V-CW-CT-01, (1) BLACK SHELF



4 (1) R52



5 (1) HARDWARE BOX, (1) DYESUB GRAPHICS

CASE # 3

LEGEND		GREY FOAM FOLDED TO FILL EMPTY SPACES OR USED AS PROTECTION
		1/8" CARDBOARD SPACER (PUT IN BETWEEN EVERY PANEL)
		DIVIDER
		1/4" WHITE FOAM (USED AS PROTECTION DOOR PANELS W/ LOCKS)
		1/4" WHITE FOAM (USED AS PROTECTION DOOR PANELS W/ LOCKS)

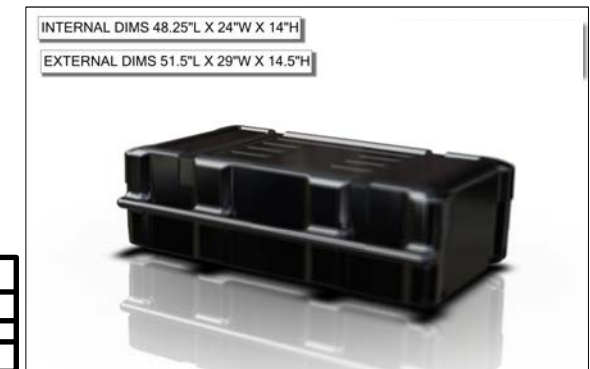

Monitor Bracket Instructions

Tube Applications



TUBE-SM-MB
Sizes: 23" - 42"
Max weight varies per application



TUBE-M-MB
Sizes: 32" - 55"
Max weight varies per application



TUBE-LG-MB
Sizes: 37" - 70"
Max weight varies per application

Included hardware:

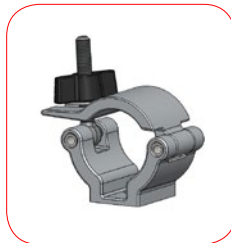

ACC60 x2



TCH-30 x2

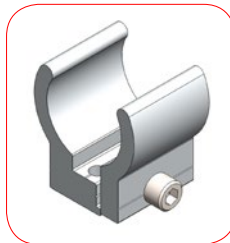

TC-30MM-SILVER x2

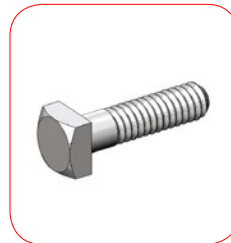

BOLT-1 x4



Flange Wingnut x4

TUBE CONNECTION

ACC60 Clamp Connection

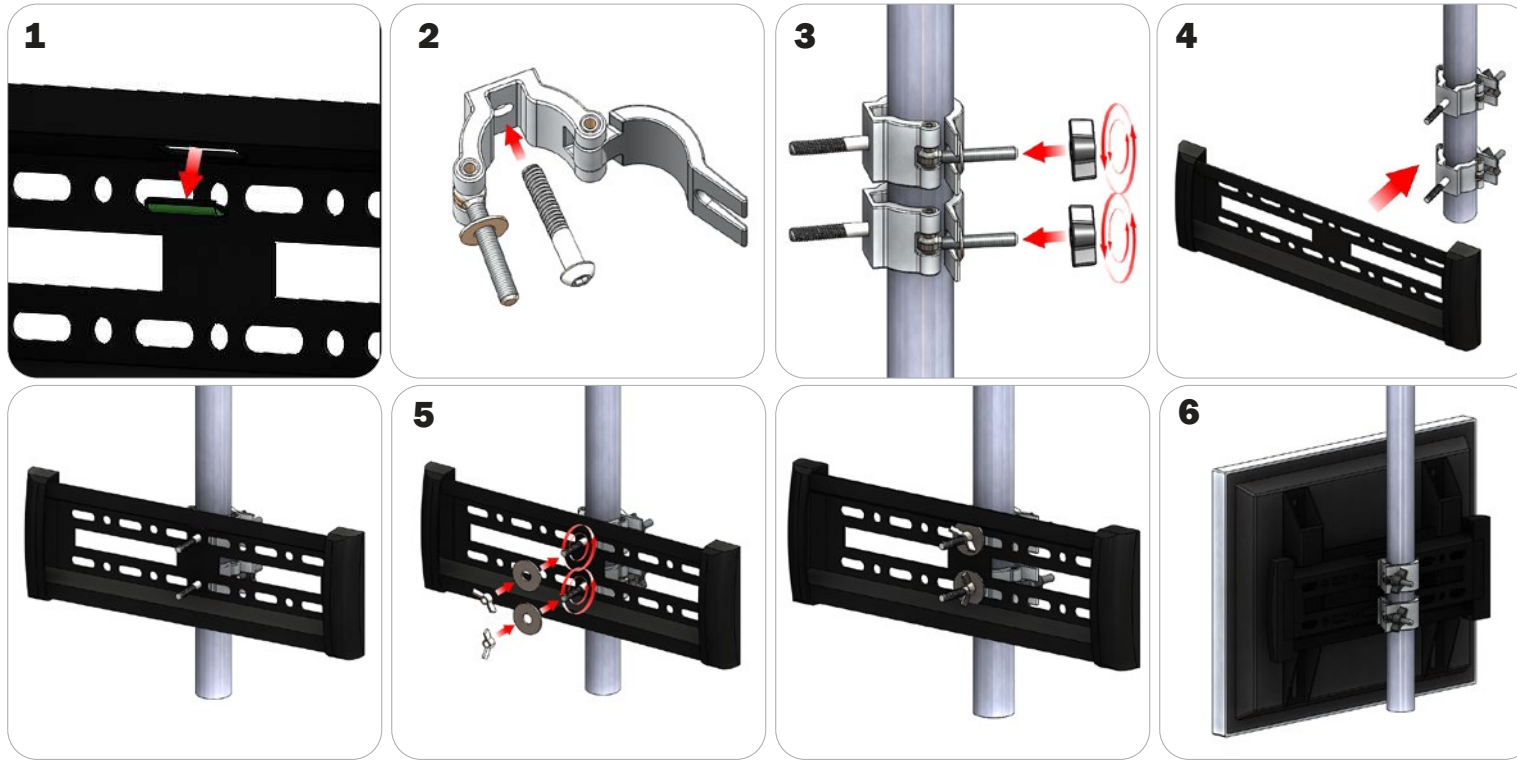

Locate all components needed to assemble the monitor mount with the ACC60 tube method. You will need (1) monitor bracket, (2) ACC60 clamps, (2) washers, and (2) wingnuts. **Step 1:** Apply pressure to the rear side of the leveling gauge clipped into the monitor mount to remove it. **Step 2:** Push the provided bolt through the hole in the ACC60 and place the ACC60 in the desired location. **Step 3:** Tighten the clamp to the tube using the plastic wingnut. **Step 4:** Set your monitor bracket onto the protruding bolts using the of the ACC60 using the center holes on the monitor bracket., adjust ACC60 position if necessary. **Step 5:** Lock your monitor bracket to the ACC60s by placing your washers and locking with provided wingnuts. **Step 6:** Reference the included manufacturer monitor mount instructions for fastening your monitor to the bracket.

TCH Clamp Connection (Tablet Stands)

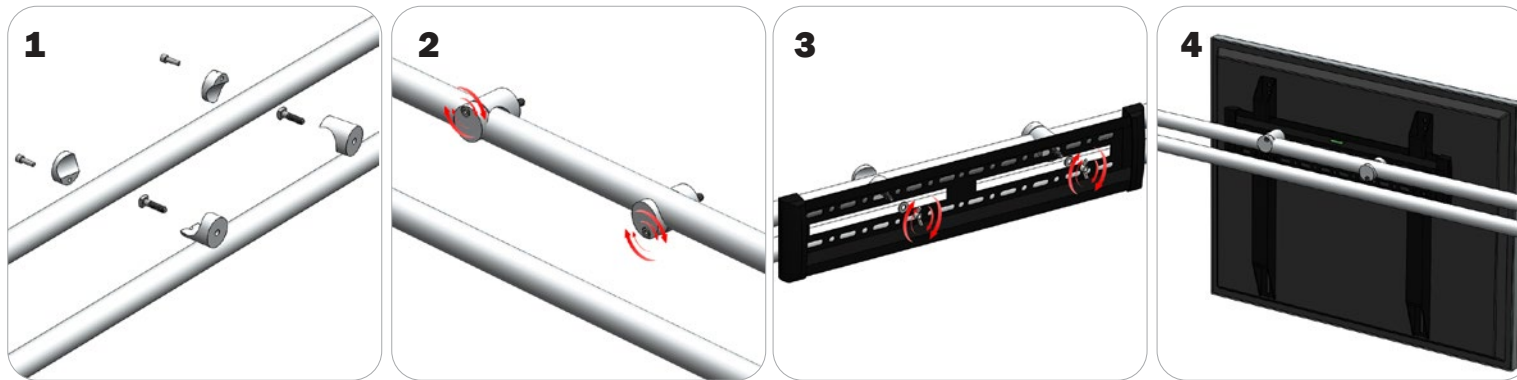

Locate all components needed to assemble the monitor mount with the TCH tube method. You will need (1) monitor bracket, (2) TCH clamps, (2) bolts, (2) washers, and (2) wingnuts. Determine your desired monitor location. **Step 1:** Fit the provided bolts through the TCH clamps then reassemble the clamp. **Step 2:** Lock the clamp onto the tube with the allen head screws on the clamp. **Step 3:** Align your monitor bracket so that the left and right holes slide onto the bolts behind them. Use your washers and wingnuts to lock your monitor bracket in place. **Step 4:** Reference the included manufacturer monitor mount instructions for fastening your monitor to the bracket.

TUBE CONNECTION

TC-30 Clamp Connection

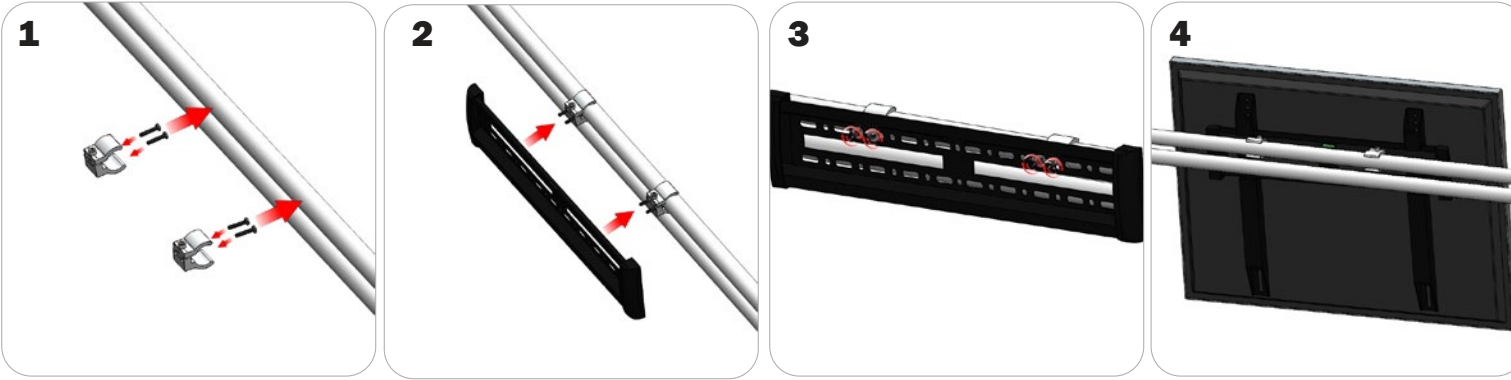

Locate all components needed to assemble the monitor mount with the TC-30 tube clamp method. You will need (1) monitor bracket, (2) TC-30-SILVER clamps, (4) BOLT-1 screws, and (4) flange wingnuts. **Step 1:** Insert the pan-head screws through the holes of your TC-30 clamps. Attach the TC-30 clamps to the tubes but do not tighten. **Step 2:** Set your monitor bracket onto the protruding pan-head screws on your clamps using the holes in the monitor bracket. **Step 3:** Apply your flange wingnuts to the front of your monitor bracket to lock it to the clamps. Lock your clamps securely into place. **Step 4:** Reference the included manufacturer monitor mount instructions for fastening your monitor to the bracket.