

Hybrid Pro Modular Kit 07

HP-K-07

Hybrid Pro™ Modular exhibits and counters are a perfect solution for the serious exhibitor. Exhibits feature heavy-duty aluminum extrusion frames and push-fit fabric graphics. Count on making an unforgettable impact with Hybrid Pro Modular exhibit kits, counters, and accessories.

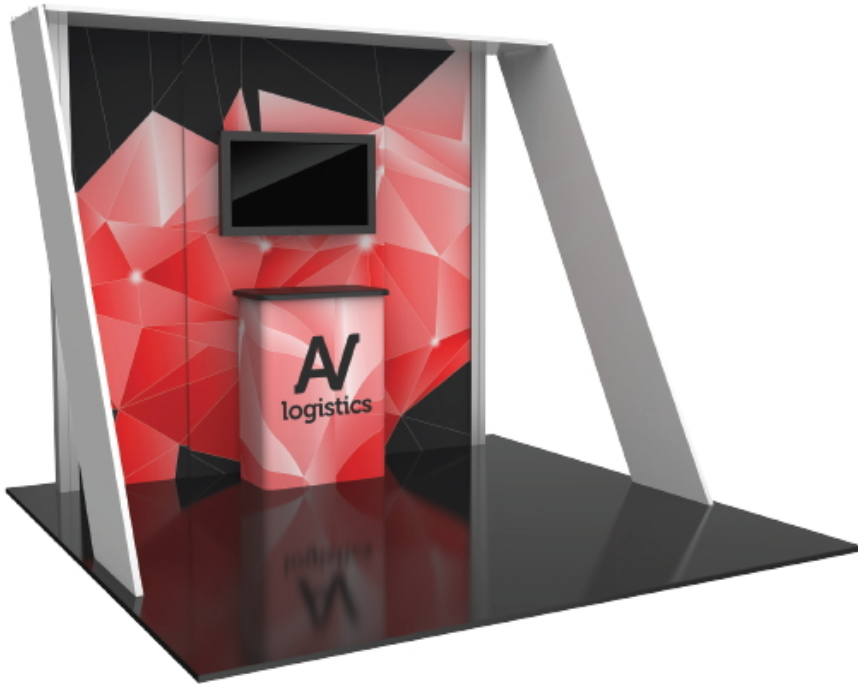

features and benefits:

- Silver aluminum extrusion frame
- Single-sided fabric graphics
- Pillowcase fabric graphic
- Easy step-by-step instructions
- Counter available in four thermoformed finishes, shown below
- Kit includes frame, side/top white accent, three fabric graphic panels, three pillowcase fabric graphics, one counter, one medium monitor mount and three molded cases
- Lifetime hardware warranty against manufacturer defects

dimensions:

Hardware

Assembled unit:
115.25" w x 95.63" h x 79.25" d
2927mm(w) x 2429mm(h) x 2013mm(d)

Approximate weight:
230 lbs / 105 kgs

Shipping

Packing case(s):
1 OCE
2 OCH2

Shipping dimensions:
OCE: Expandable case length (l) may vary
40" - 66" l x 18" h x 18" d
1016mm-1677mm(l) x 458mm(h) x 458mm(d)

OCH2:
52" l x 29" h x 15" d
1321mm(l) x 737mm(h) x 381mm(d)

Approximate total shipping weight:
317 lbs / 144 kgs

Graphic

Refer to related graphic template for more information.

Visit:
www.exhibitors-handbook.com/graphic-templates

additional information:

Graphic material:
Dye-sublimation zipper pillowcase fabric
Dye-sublimation SEG push-fit fabric

Monitor mount holds 32 - 55" LCD's
Monitor max weight: 50 lbs / 37 kgs

Max counter weight: 50 lbs / 23 kgs

*monitor not included

Tabletop Colors:



2 person assembly recommended:



We are continually improving and modifying our product range and reserve the right to vary the specifications without prior notice. All dimensions and weights quoted are approximate and we accept no responsibility for variance. E&OE. See Graphic Templates for graphic bleed specifications.

R-HP-K-07

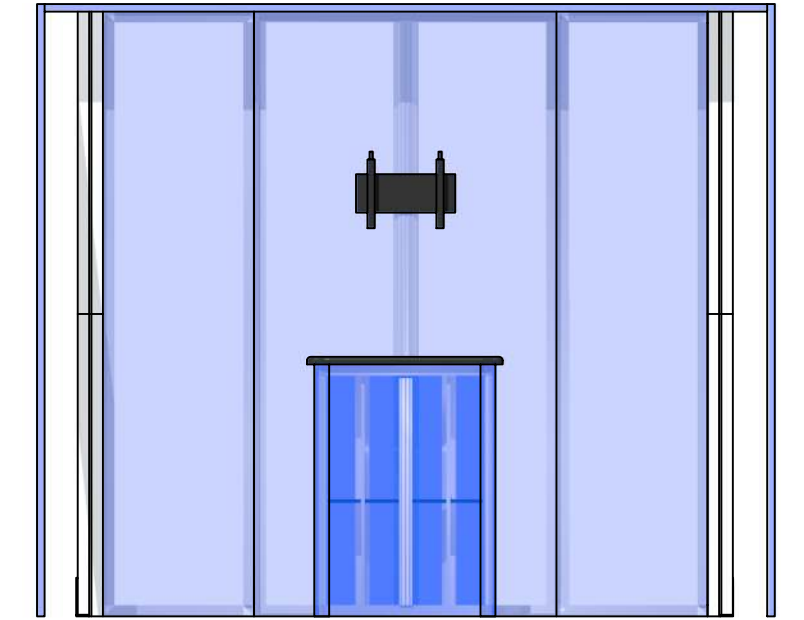
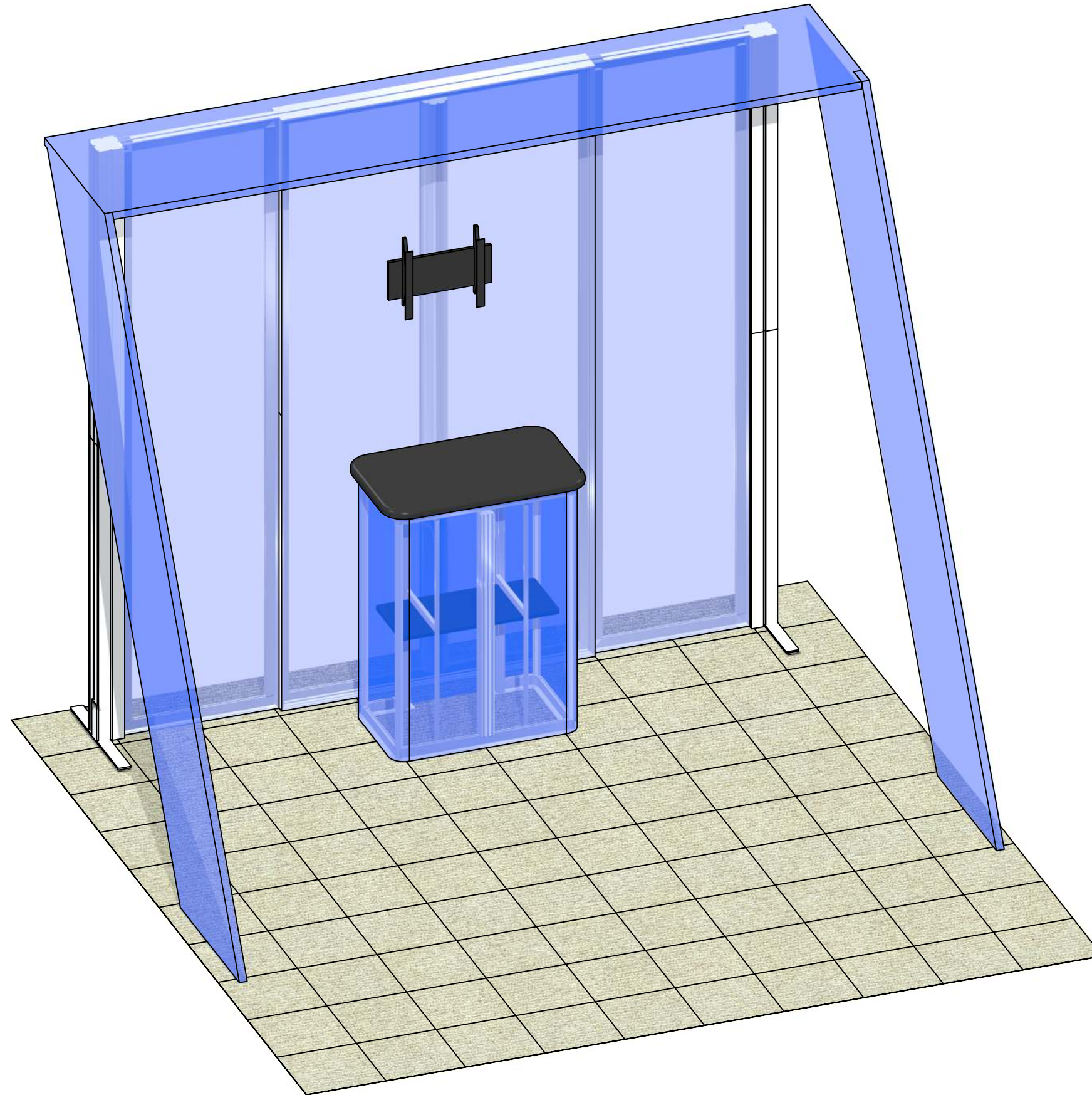

Code	#	Description
EXT-M-MB	1	MEDIUM MONITOR BRACKET FOR MONITORS 32"-55"
R9	2	1200MM (47.24") PHFC4 EXTRUSION WITH MITRE CUT BOTH ENDS
R27	4	1200MM (47.24") PHFC4 EXTRUSION WITH MITRE CUT 1 END FOR CB9 ONE END-IB2 HOLES ONE END
R55	4	510MM (20.08") PHFC2 EXTRUSION WITH LOCKS 2 ENDS
R19	8	1155MM (45.47") PHFC2 EXTRUSION WITH IB2 HOLE ONE SIDE-WITH LOCK 1 END WITH SIDE CAM LOCKS
R15	4	1200MM (47.24") 100MM PM4S2 SQUARE EXTRUSION WITH PH2 STOP AT 600MM
GRAPHIC B	1	94 1/2" (H) X 47 1/4" (W) SINGLE SIDED DYESUB GRAPHIC W/ FCE-2 (SEG) ON PERIMETER
GRAPHIC A2	1	94 1/2" (H) X 23 5/8" (W) SINGLE SIDED DYESUB GRAPHIC W/ FCE-2 (SEG) ON PERIMETER
R12	2	1155MM (45.47") 100MM PM4R8 ROUND EXTRUSION WITH LOCKS 1 END WITH PH2 STOP AT 155MM
R13	2	600MM (23.62") PM4D CONNECTOR WITH TENSION GLIDES
IB2	6	PH INLINE CONNECTOR
CB9-S	8	50MM SQUARE PHCF2 CORNER BRACKET
GRAPHIC A1	1	94 1/2" (H) X 23 5/8" (W) SINGLE SIDED DYESUB GRAPHIC W/ FCE-2 (SEG) ON PERIMETER
CB9	4	CB9 CORNER BRACKET
CUSTOM FS	1	APPROXIMATELY 8' X 10' X 8' CUSTOM FABRIC STRUCTURE - TO PACK INTO OCE -
R14	1	300MM (11.81") PM4D CONNECTOR WITH TENSION GLIDES
SW-FOOT	2	SMARTWALL SUPPORT FOOT

BOM

R-HP-K-07

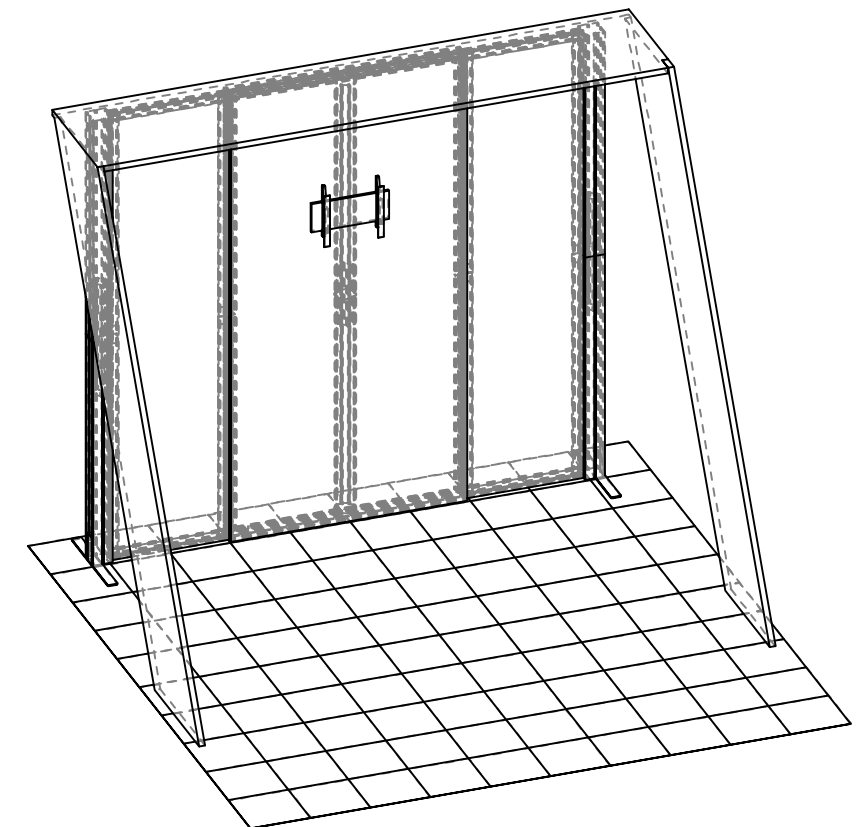
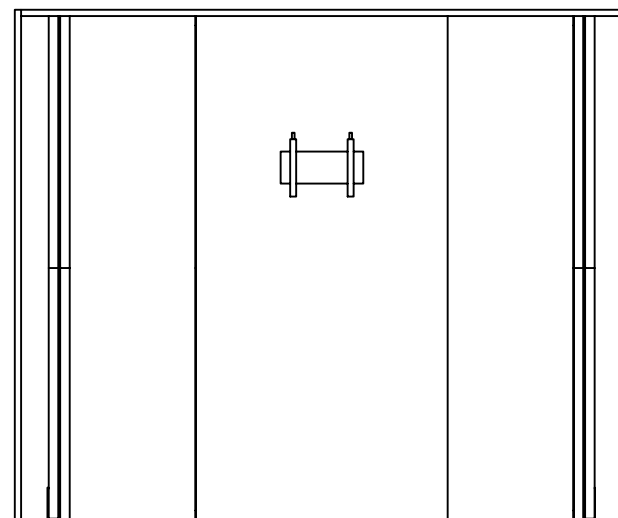
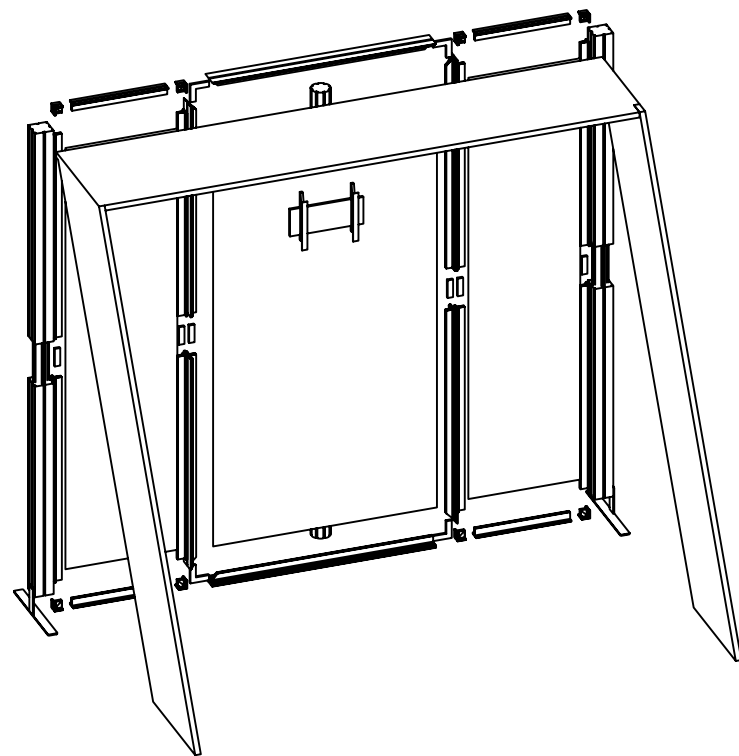
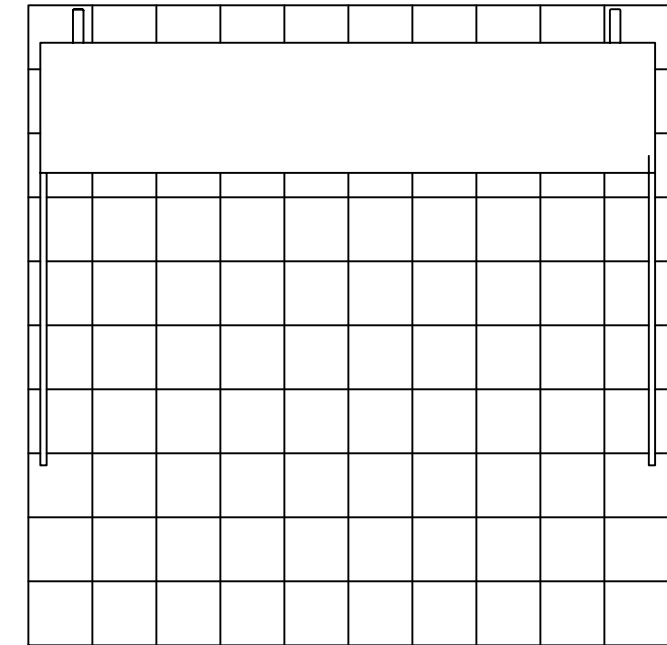

1. Redesign of this exhibit without approval by manufacturer may result in dangerous and unsafe structures. Manufacturer disclaims any responsibility for redesigned exhibits it does not approve in writing.

2. Parts and components such as panels and extrusions are manufactured to metric sizing. Where ever possible sizes have been noted in feet and inches as well as in metric. Below is the imperial to metric sizing table as reference. "Nominal" refers to approximate size.

- | | |
|--------------------|-----------------------------------|
| 2400mm = (94 1/2") | ▼ Phone Line / Fax |
| 2100mm = (82 5/8") | ▼ Internet connection |
| 1800mm = (70 7/8") | ▼ Outlet |
| 1500mm = (59") | ▼ Main Drop (point of distrution) |
| 1200mm = (47 1/4") | |
| 900mm = (35 1/2") | |
| 600mm = (23 5/8") | |
| 300mm = (11 7/8") | |
- Wire running under carpet

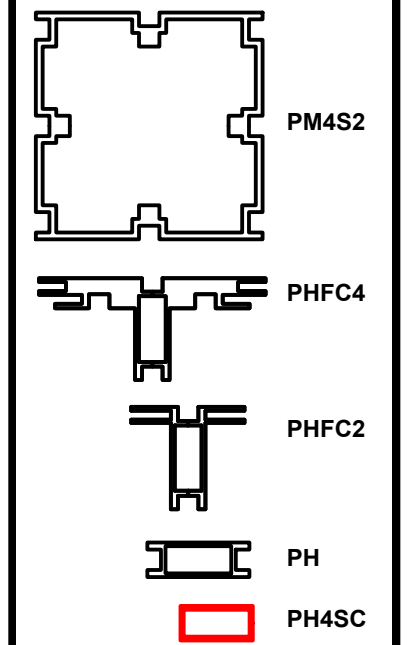
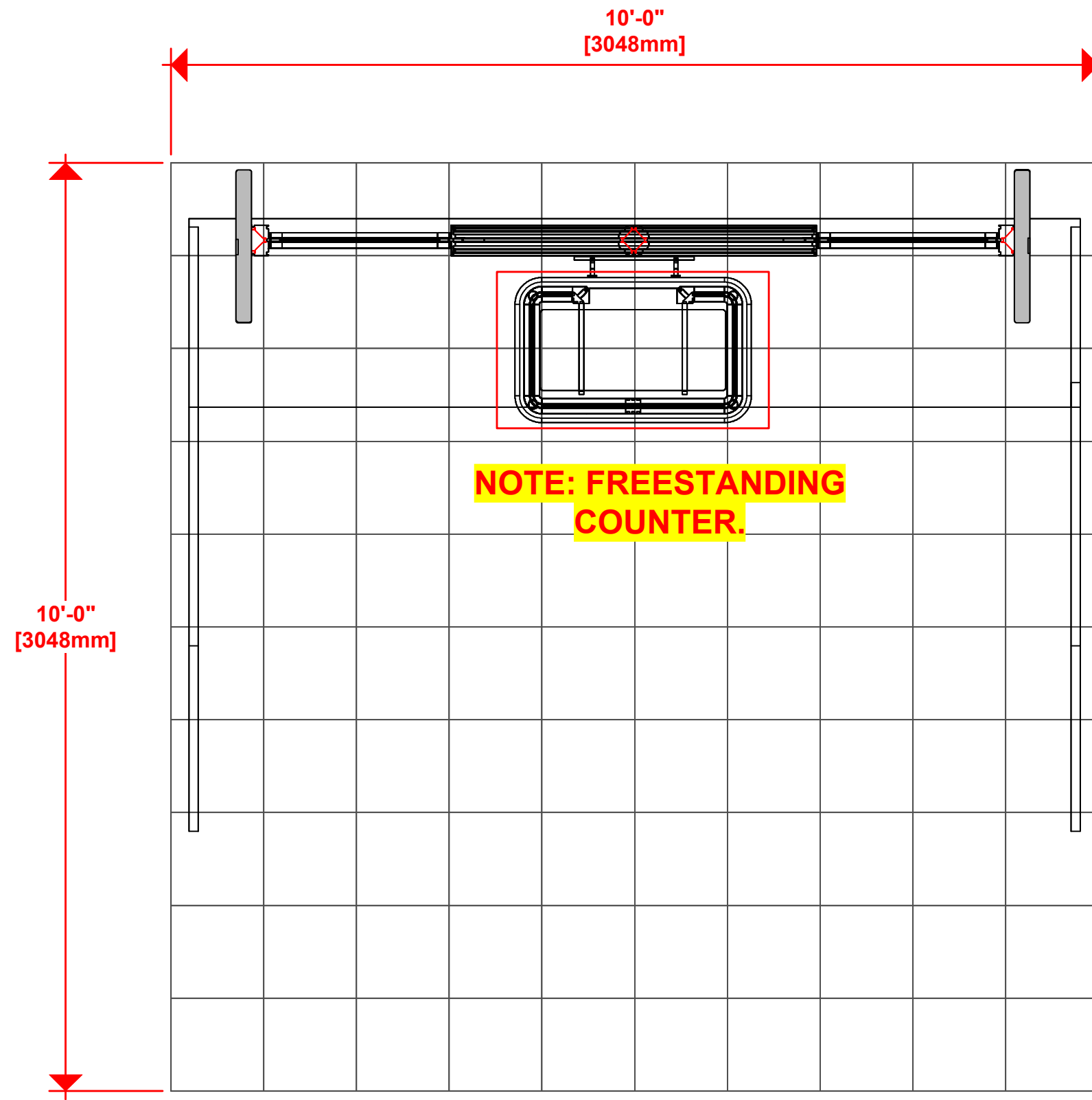

HYBRID PRO RENTAL KIT

Title: SET-UP INSTRUCTIONS

Code	#	Description
R9	2	1200MM (47.24") PHFC4 EXTRUSION WITH MITRE CUT BOTH ENDS
R27	4	1200MM (47.24") PHFC4 EXTRUSION WITH MITRE CUT 1 END FOR CB9 ONE EN
R12	2	1155MM (45.47") 100MM PM4R8 ROUND EXTRUSION WITH LOCKS 1 END WITH
IB2	2	PH INLINE CONNECTOR
CB9	4	CB9 CORNER BRACKET
R14	1	300MM (11.81") PM4D CONNECTOR WITH TENSION GLIDES

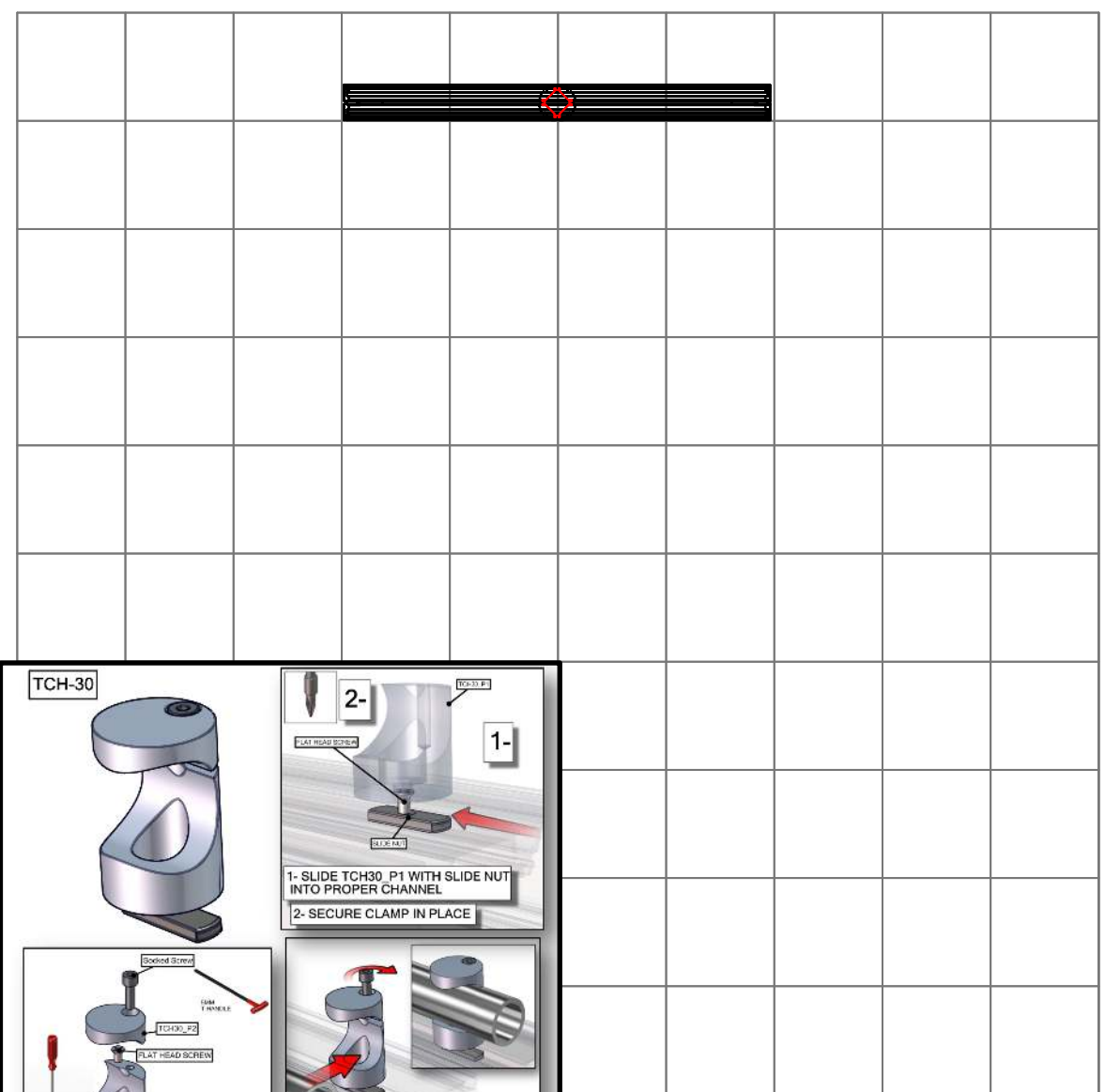
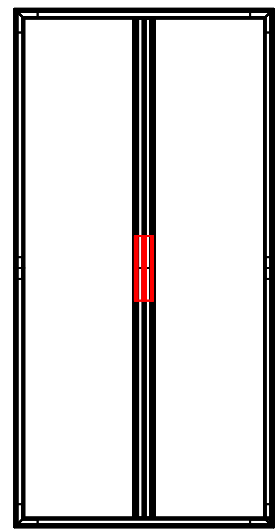
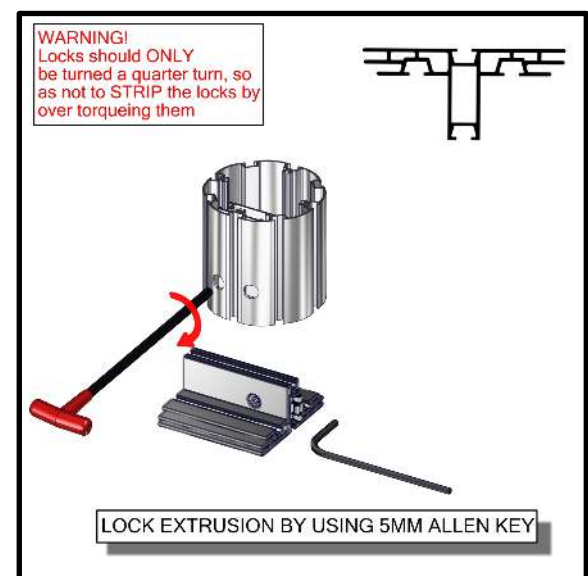
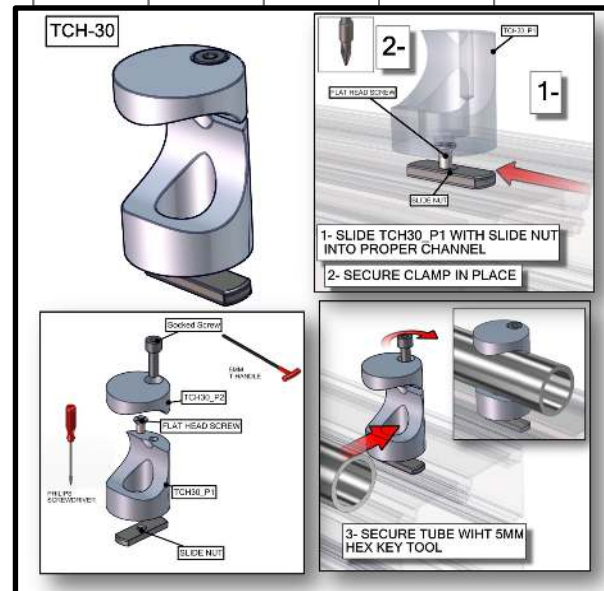
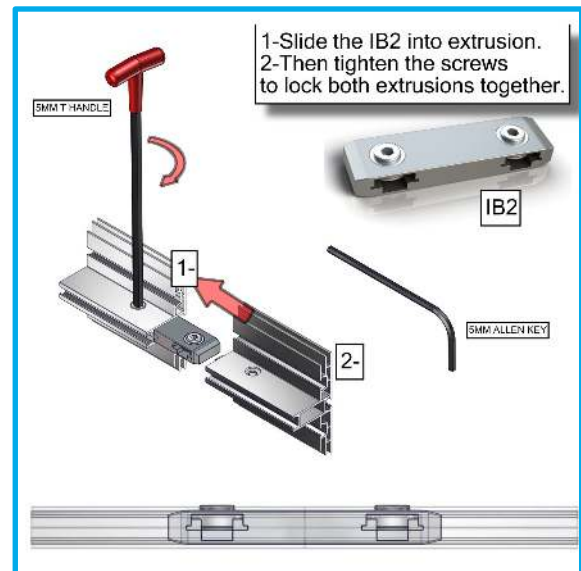
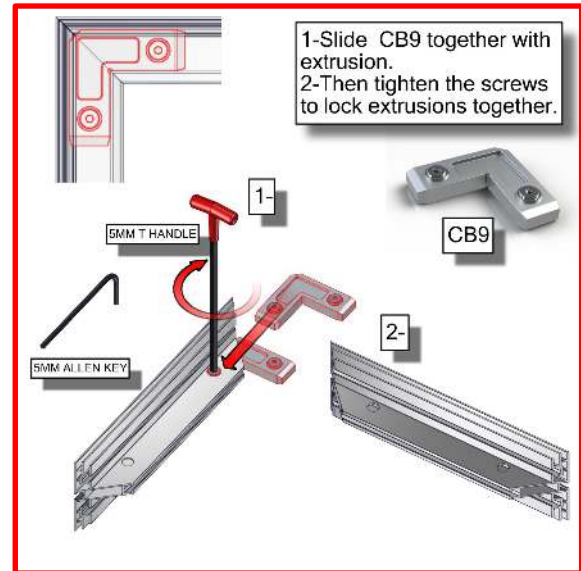
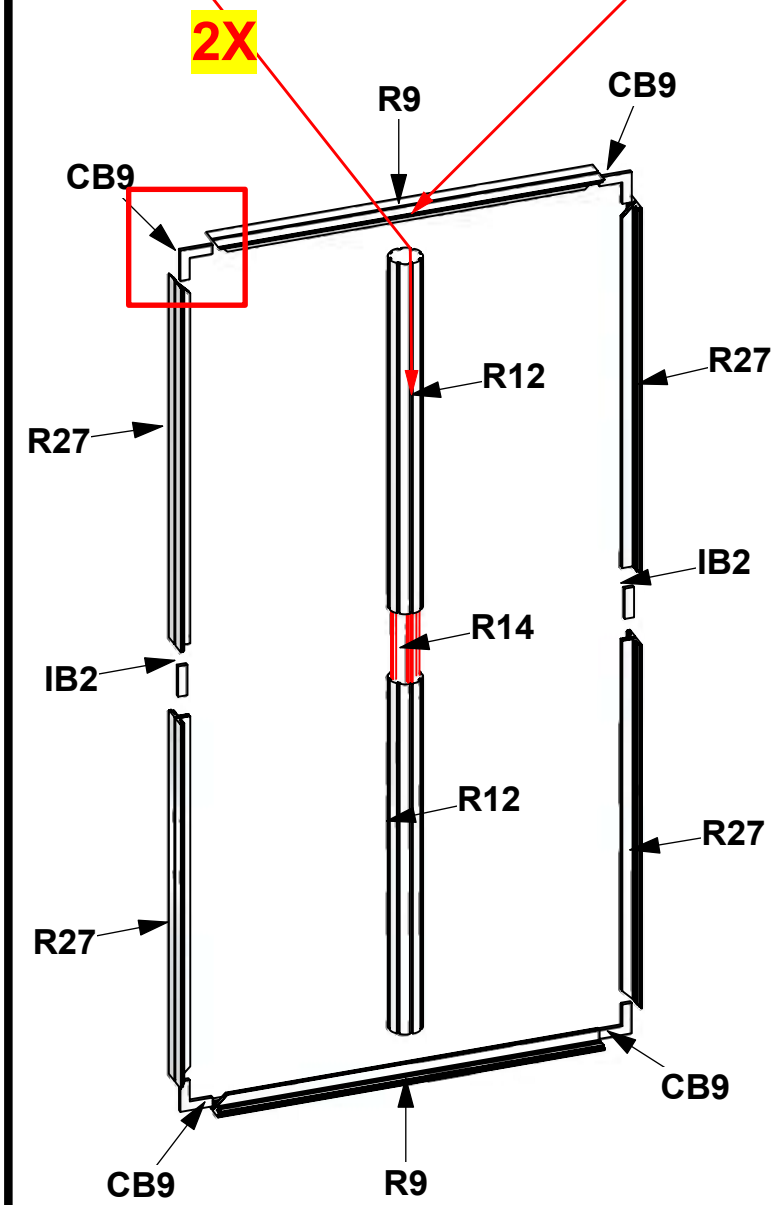
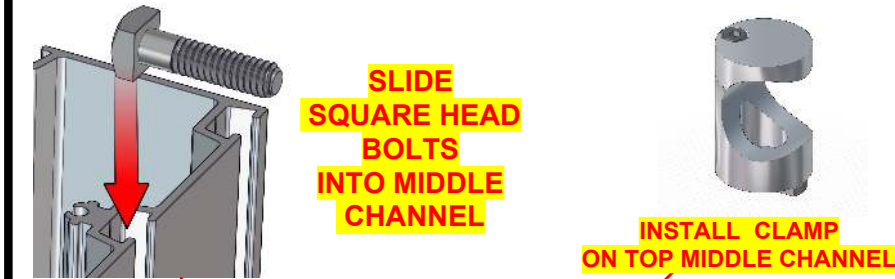

1. Redesign of this exhibit without approval by manufacturer may result in dangerous and unsafe structures. Manufacturer disclaims any responsibility for redesigned exhibits it does not approve in writing.

2. Parts and components such as panels and extrusions are manufactured to metric sizing. Where ever possible sizes have been noted in feet and inches as well as in metric. Below is the imperial to metric sizing table as reference. "Nominal" refers to approximate size.

2400mm = (94 1/2")	Phone Line / Fax
2100mm = (82 5/8")	Internet connection
1800mm = (70 7/8")	Outlet
1500mm = (59")	Main Drop (point of distrution)
1200mm = (47 1/4")	
900mm = (35 1/2")	
600mm = (23 5/8")	
300mm = (11 7/8")	

--- Wire running under carpet

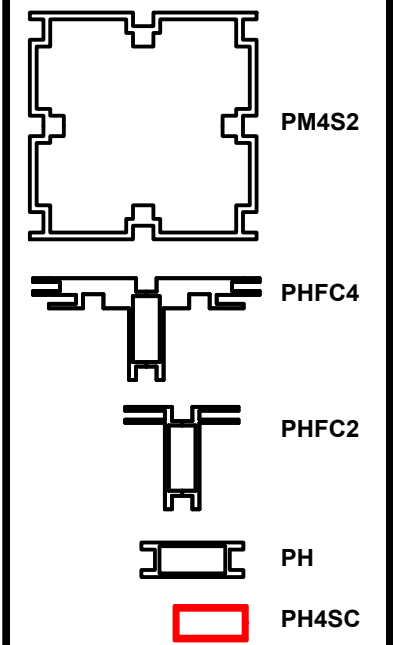

HYBRID PRO RENTAL KIT

Title: SET-UP INSTRUCTIONS

Code	#	Description
R55	4	510MM (20.08") PHFC2 EXTRUSION WITH LOCKS 2 ENDS
R19	8	1155MM (45.47") PHFC2 EXTRUSION WITH IB2 HOLE ONE SIDE-WITH LOCK 1 EN
IB2	4	PH INLINE CONNECTOR
CB9-S	8	50MM SQUARE PHCF2 CORNER BRACKET

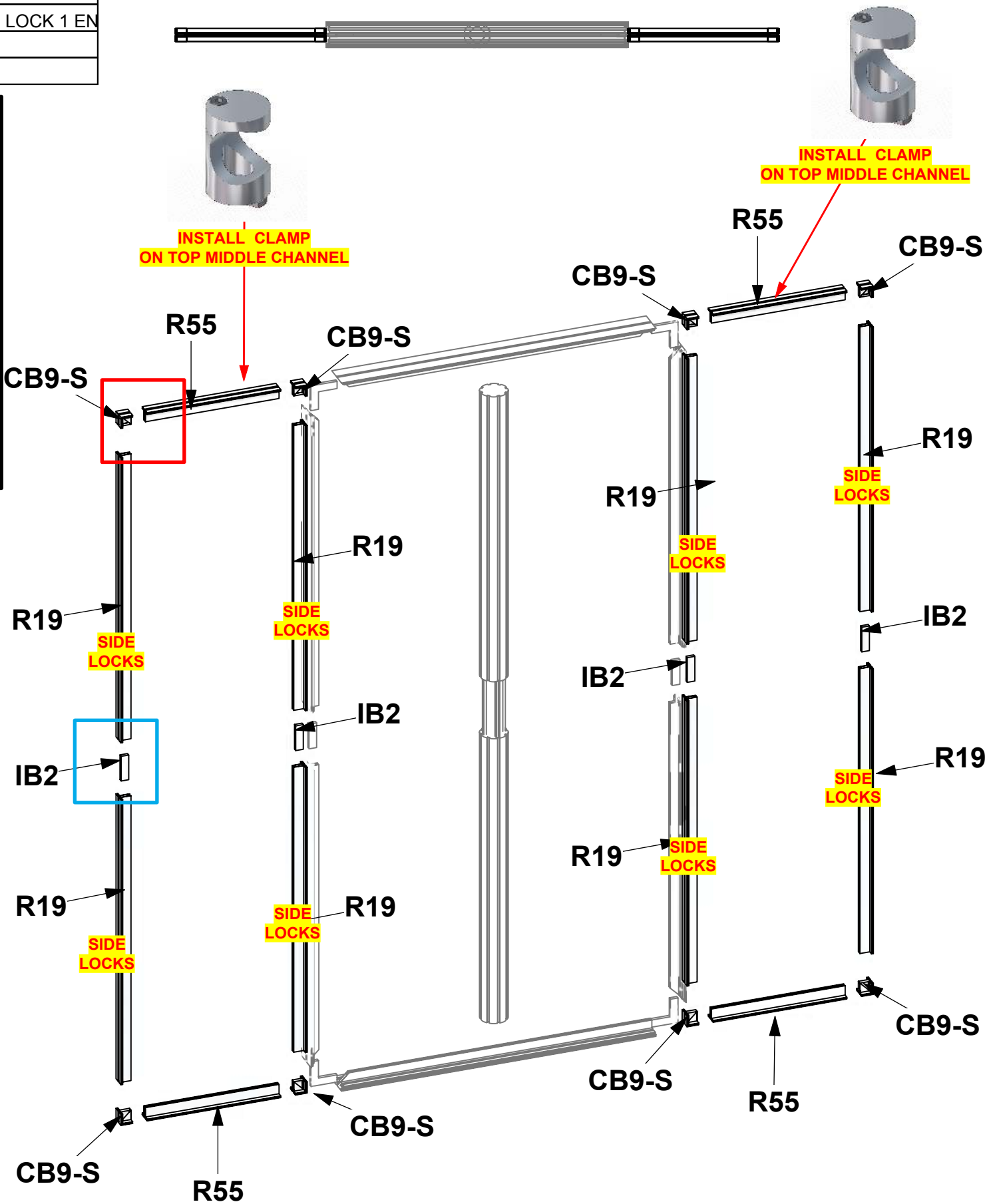
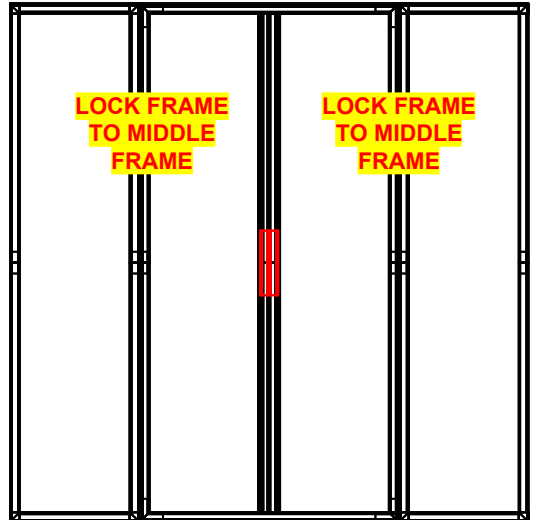
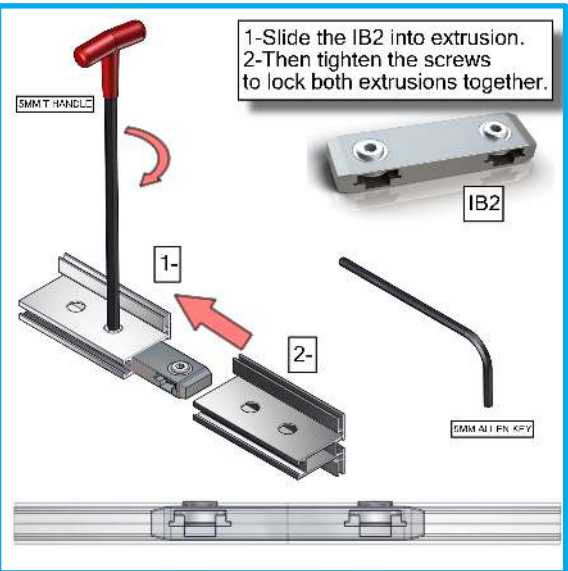
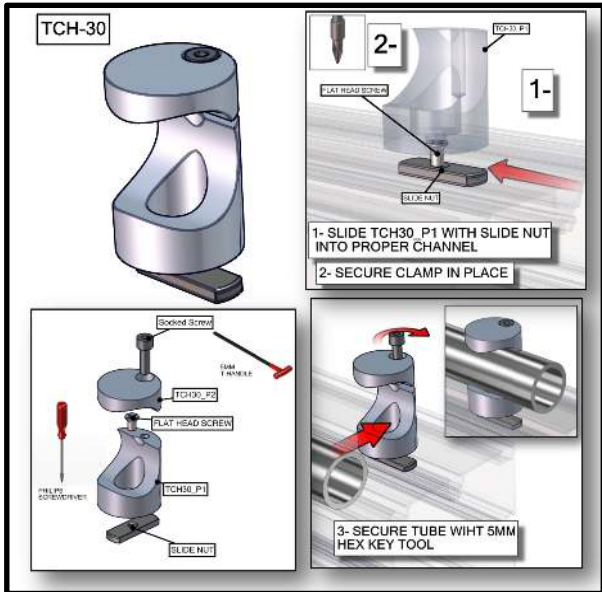
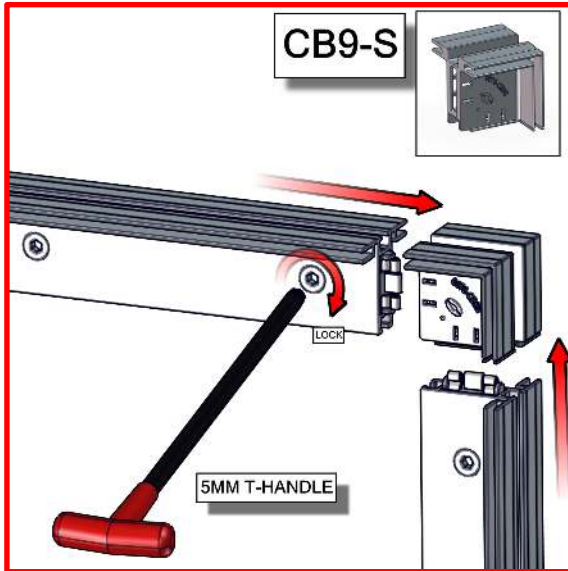

1. Redesign of this exhibit without approval by manufacturer may result in dangerous and unsafe structures. Manufacturer disclaims any responsibility for redesigned exhibits it does not approve in writing.

2. Parts and components such as panels and extrusions are manufactured to metric sizing. Where ever possible sizes have been noted in feet and inches as well as in metric. Below is the imperial to metric sizing table as reference. "Nominal" refers to approximate size.

2400mm = (94 1/2")
 2100mm = (82 5/8")
 1800mm = (70 7/8")
 1500mm = (59")
 1200mm = (47 1/4")
 900mm = (35 1/2")
 600mm = (23 5/8")
 300mm = (11 7/8")

Phone Line / Fax
 Internet connection
 Outlet
 Main Drop (point of distrution)
 Wire running under carpet

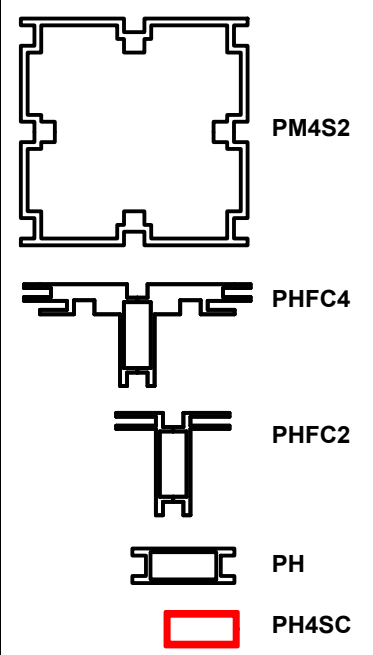

HYBRID PRO RENTAL KIT

Title: SET-UP INSTRUCTIONS

Code	#	Description
R15	4	1200MM (47.24") 100MM PM4S2 SQUARE EXTRUSION WITH PH2 STOP AT 600M
R13	2	600MM (23.62") PM4D CONNECTOR WITH TENSION GLIDES
SW-FOOT	2	SMARTWALL SUPPORT FOOT

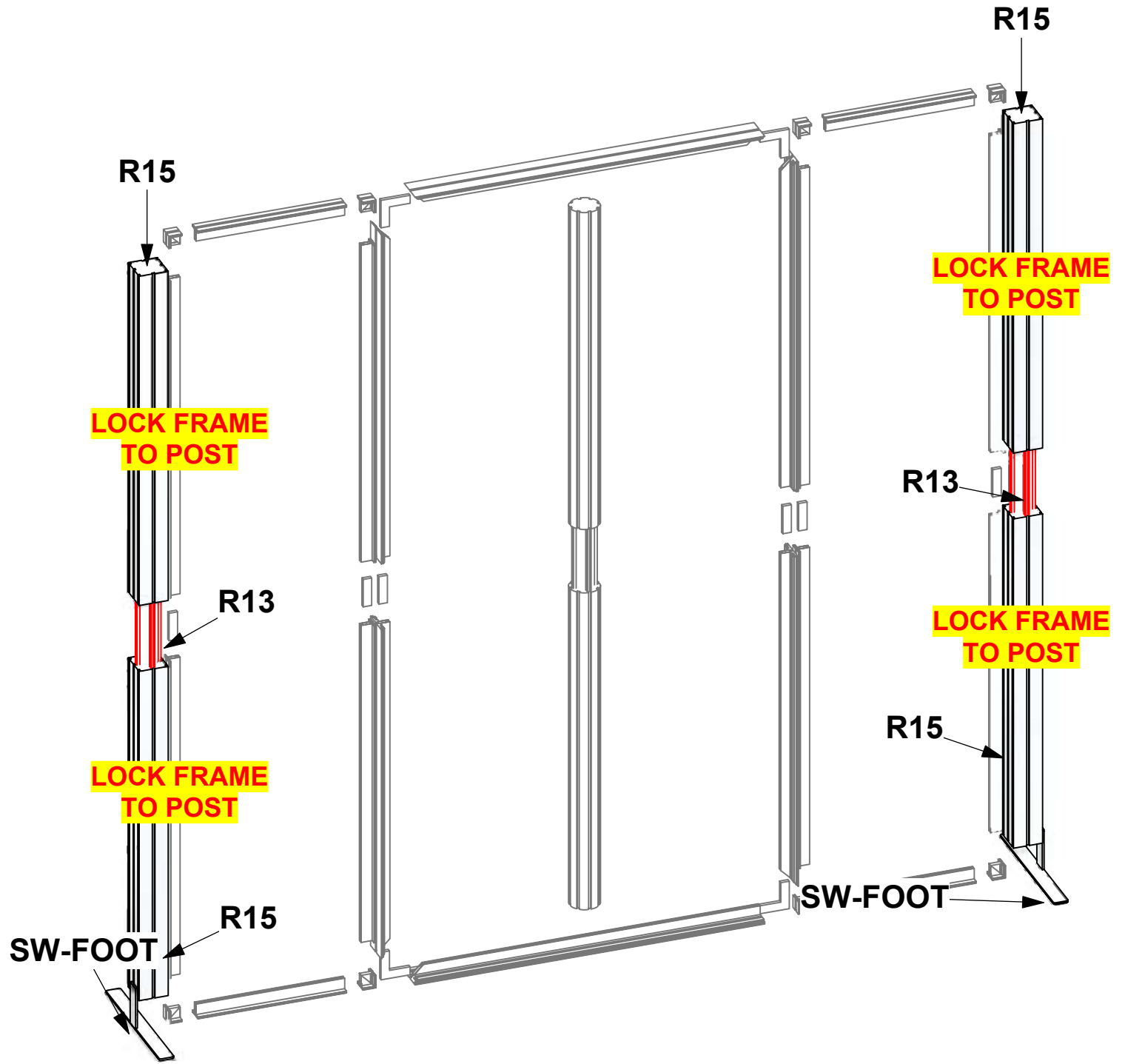
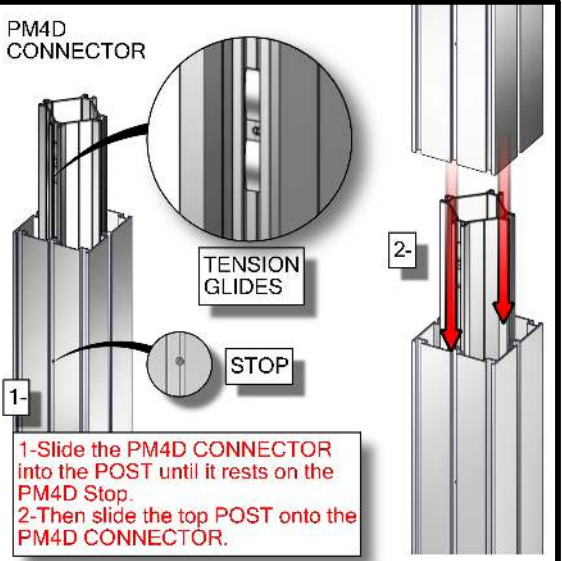
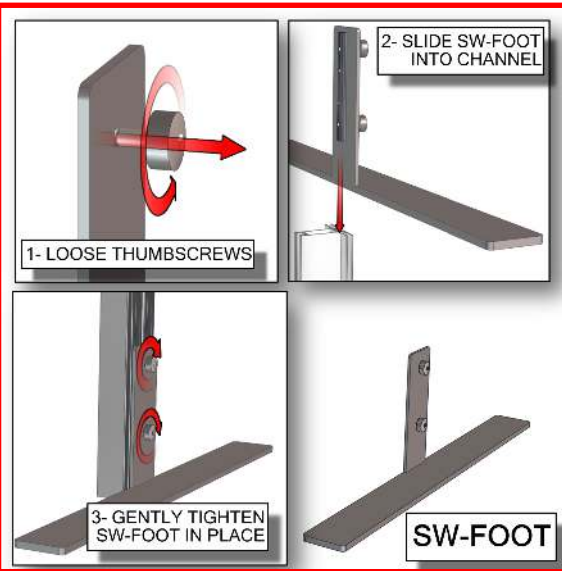

1. Redesign of this exhibit without approval by manufacturer may result in dangerous and unsafe structures. Manufacturer disclaims any responsibility for redesigned exhibits it does not approve in writing.

2. Parts and components such as panels and extrusions are manufactured to metric sizing. Where ever possible sizes have been noted in feet and inches as well as in metric. Below is the imperial to metric sizing table as reference. "Nominal" refers to approximate size.

2400mm = (94 1/2")	Phone Line / Fax
2100mm = (82 5/8")	Internet connection
1800mm = (70 7/8")	Outlet
1500mm = (59")	Main Drop (point of distrution)
1200mm = (47 1/4")	
900mm = (35 1/2")	
600mm = (23 5/8")	
300mm = (11 7/8")	

--- Wire running under carpet

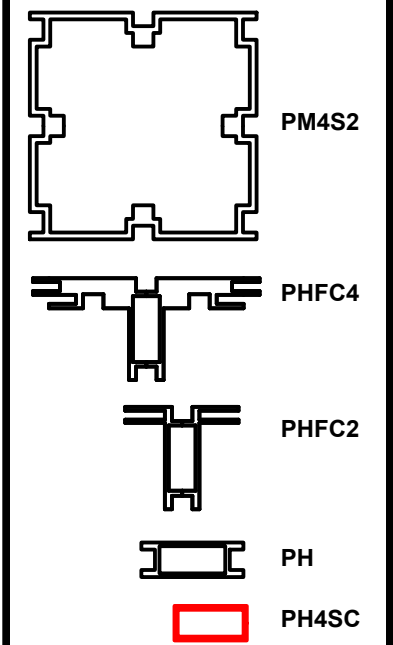

HYBRID PRO RENTAL KIT

Title: SET-UP INSTRUCTIONS

Code	#	Description
EXT-M-MB	1	MEDIUM MONITOR BRACKET FOR MONITORS 32"-55"
GRAPHIC B	1	94 1/2" (H) X 47 1/4" (W) SINGLE SIDED DYESUB GRAPHIC W/ FCE-2 (SEG) ON PERIMETER
GRAPHIC A2	1	94 1/2" (H) X 23 5/8" (W) SINGLE SIDED DYESUB GRAPHIC W/ FCE-2 (SEG) ON PERIMETER
GRAPHIC A1	1	94 1/2" (H) X 23 5/8" (W) SINGLE SIDED DYESUB GRAPHIC W/ FCE-2 (SEG) ON PERIMETER

EXT-M-MB

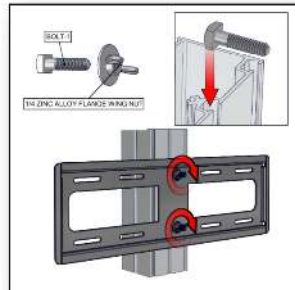
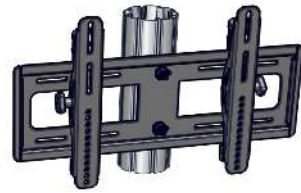
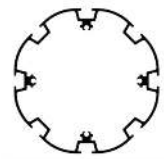

1- INSERT BOLTS INTO MIDDLE CHANNEL. THEN SECURE MONITOR MOUNT WITH WING NUTS.

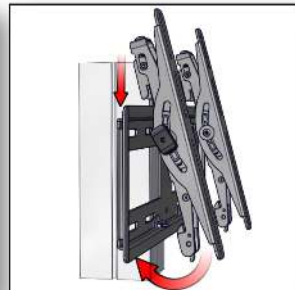

2- ATTACH MONITOR TO BRACKETS SEE SANUS MANUAL FOR MORE INFO

FCE-2 TO PHFC2

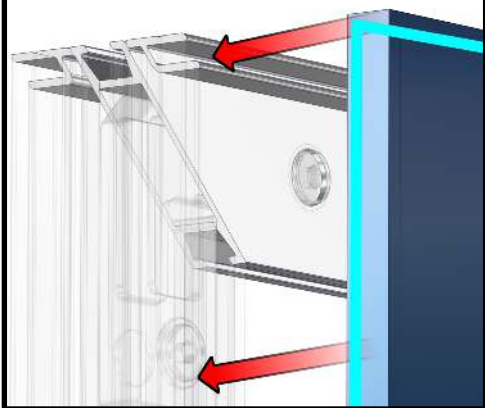

FCE-2 TO PHFC4

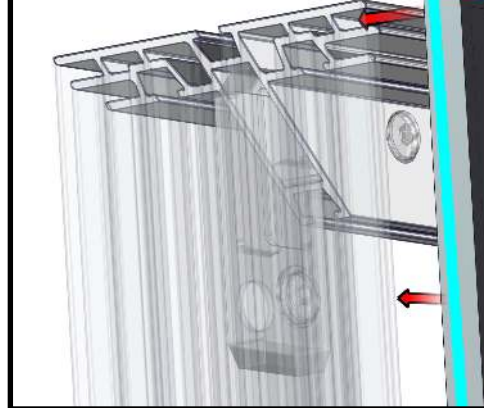

FCE-2 TO PHFC4

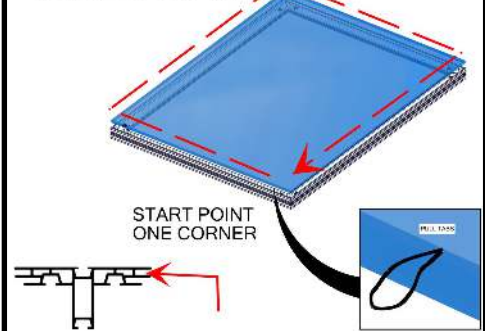

Install graphic by pressing the FCE-2 into the channels of PHFC4 extrusion. To pull graphics out of the channels, use tabs on the front side

FCE-2 TO PHFC2

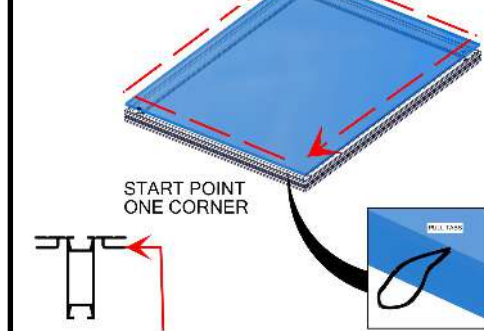

Install graphic by pressing the FCE-2 into the channels of PHFC2 extrusion. To pull graphics out of the channels, use tabs on the front side

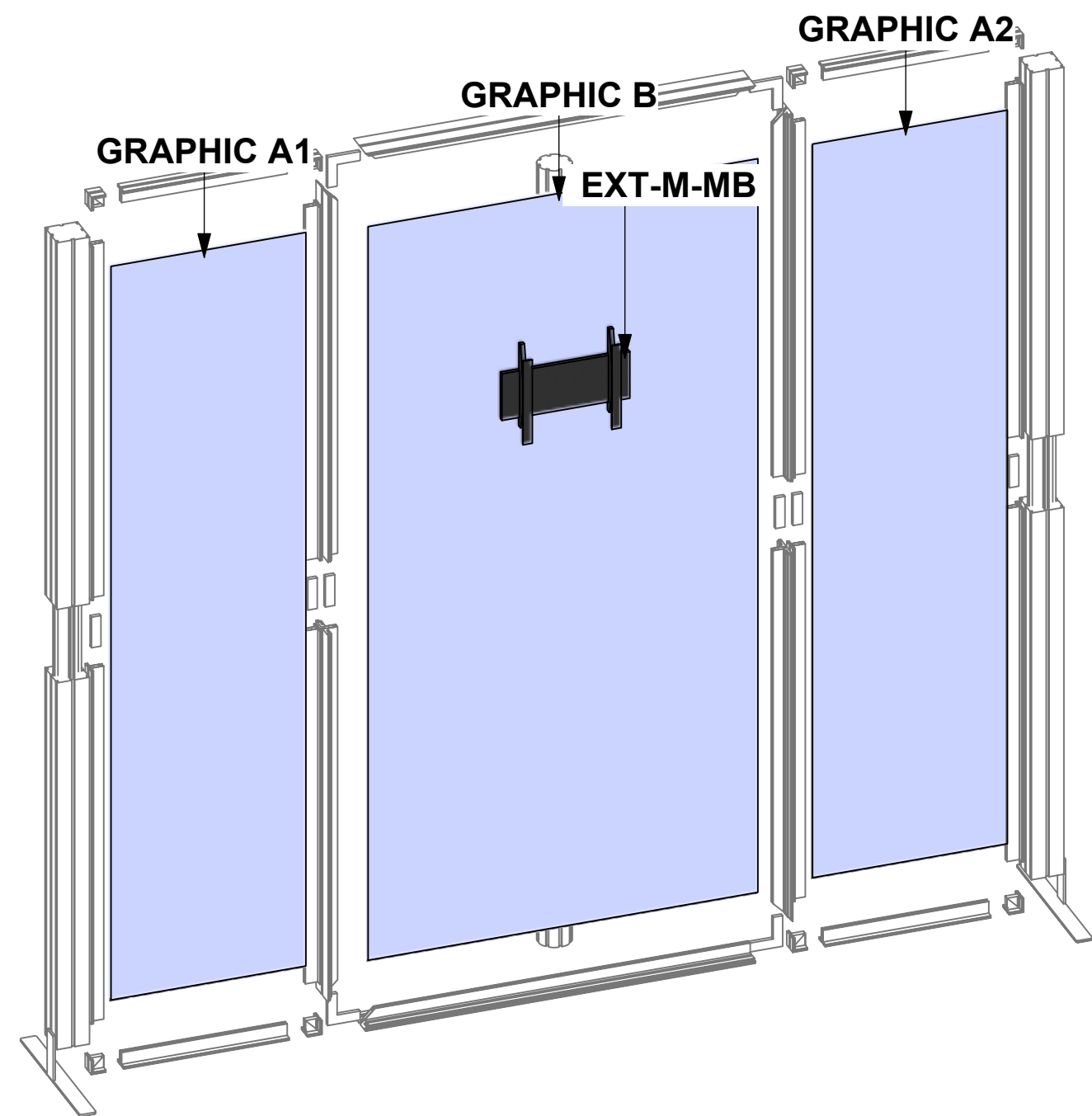
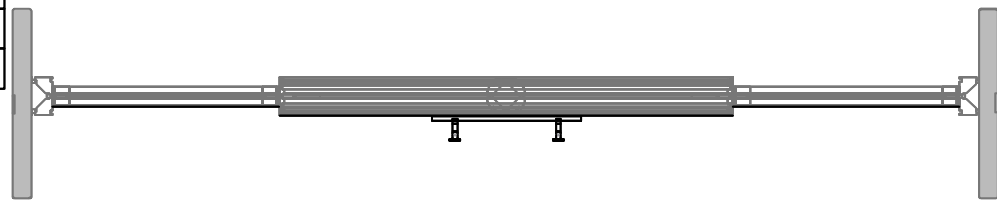

1. Redesign of this exhibit without approval by manufacturer may result in dangerous and unsafe structures. Manufacturer disclaims any responsibility for redesigned exhibits it does not approve in writing.

2. Parts and components such as panels and extrusions are manufactured to metric sizing. Where ever possible sizes have been noted in feet and inches as well as in metric. Below is the imperial to metric sizing table as reference. "Nominal" refers to approximate size.

2400mm = (94 1/2")	Phone Line / Fax
2100mm = (82 5/8")	Internet connection
1800mm = (70 7/8")	Outlet
1500mm = (59")	Main Drop (point of distrution)
1200mm = (47 1/4")	
900mm = (35 1/2")	
600mm = (23 5/8")	
300mm = (11 7/8")	

--- Wire running under carpet

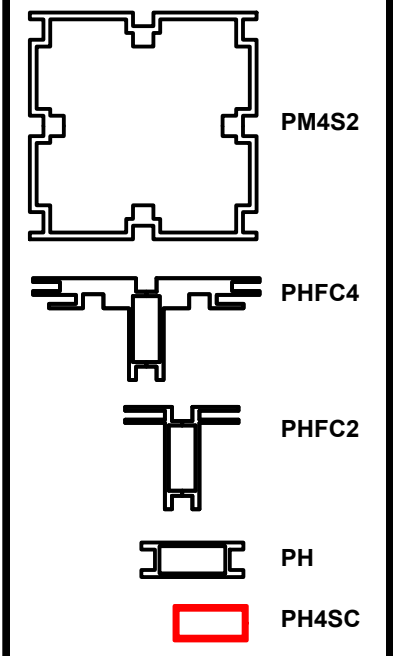

HYBRID PRO RENTAL KIT

Title: SET-UP INSTRUCTIONS

SET UP INSTRUCTIONS:

1. CONNECT BOTTOM AND TOP RAILS FOLLOWING THE LABELS
2. CONNECT SIDE RAILS
3. CLEAN THE FRAME AND PLACE THEM ON CLEAN PLACE
4. CAREFULLY REMOVE FABRIC COVER FROM BAGS
5. PLACE COVER AROUND THE BOTTOM OF THE FRAME
6. PULL COVER CAREFULLY UP TO THE TOP
7. CLOSE ALL ZIPPERS
8. ADJUST FABRIC AROUND THE FRAME

BREAK DOWN INSTRUCTIONS:

REVERSE SET-UP STEPS TO BREAKDOWN FRAME

FABRIC CARE INSTRUCTIONS:

1. UNZIP COVER ZIPPERS
2. CAREFULLY REMOVE FABRIC COVER
3. CLOSE ALL ZIPPERS
4. FOLD OR ROLL NEATLY
5. PLACE FABRIC IN COVER BAG

PART LIST:

- PER UNIT
- 21 30MM DIA. TUBE SECTIONS
 - 26 ES-30 EXPANDING SPIGOT
 - 1 2.5MM HEX KEY
 - 3 TCH-30 CLAMPS
 - 1 FABRIC COVER

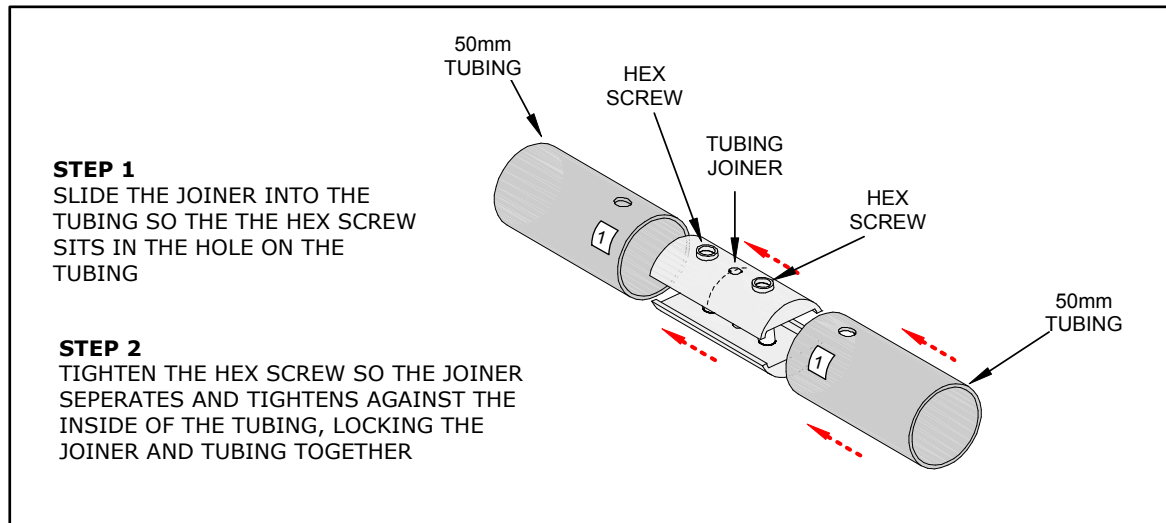
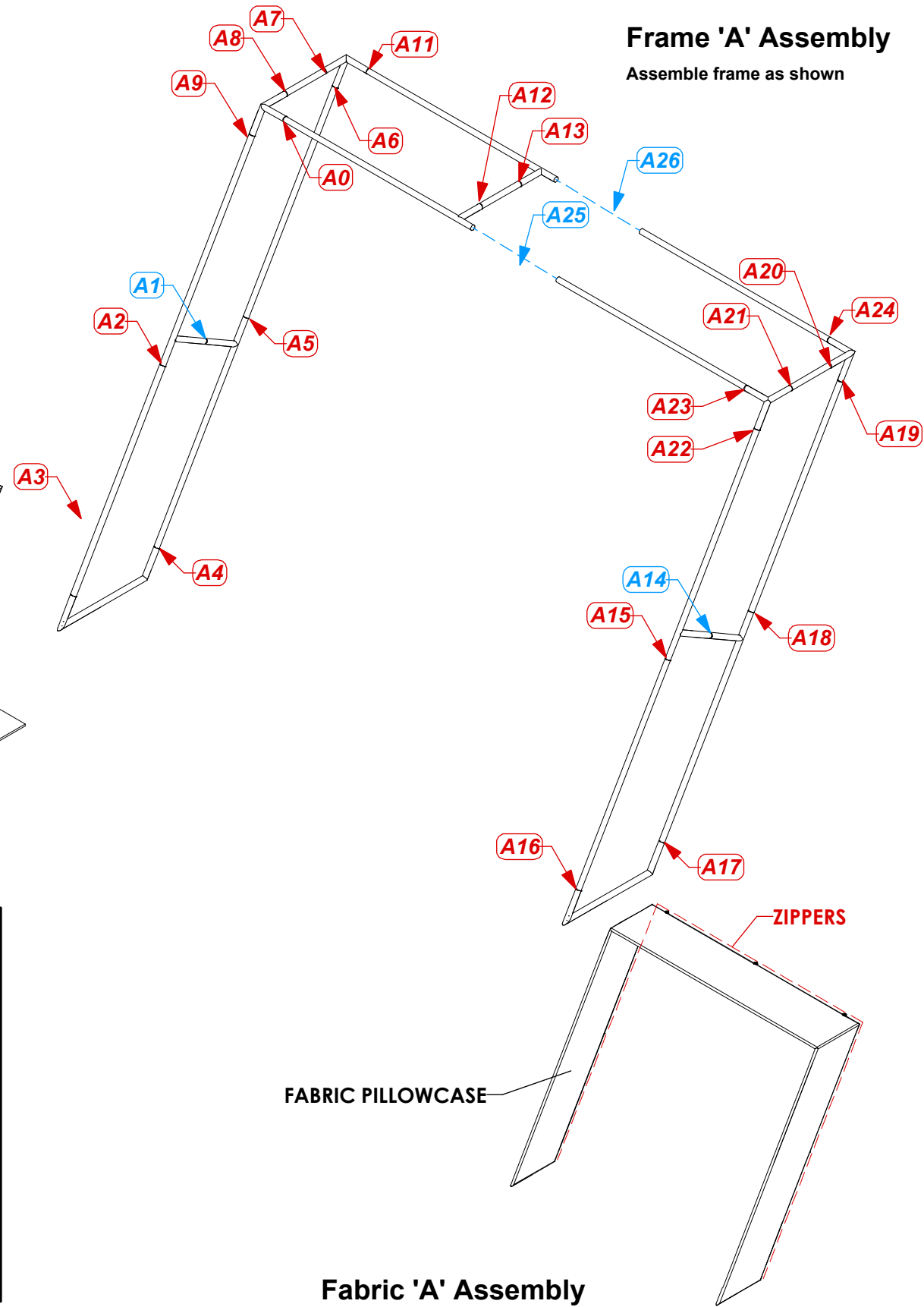
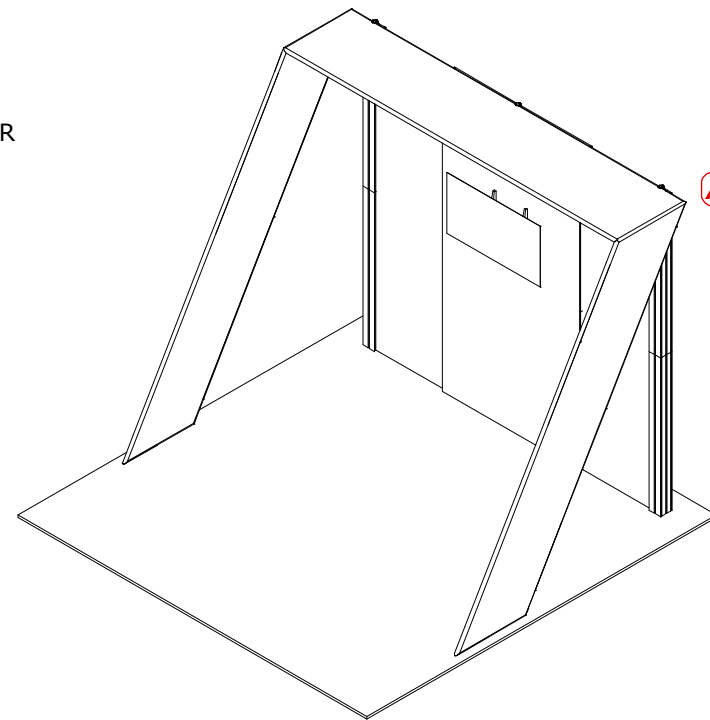

1. Redesign of this exhibit without approval by manufacturer may result in dangerous and unsafe structures. Manufacturer disclaims any responsibility for redesigned exhibits it does not approve in writing.

2. Parts and components such as panels and extrusions are manufactured to metric sizing. Where ever possible sizes have been noted in feet and inches as well as in metric. Below is the imperial to metric sizing table as reference. "Nominal" refers to approximate size.

2400mm = (94 1/2")	Phone Line / Fax
2100mm = (82 5/8")	Internet connection
1800mm = (70 7/8")	Outlet
1500mm = (59")	Main Drop (point of distrution)
1200mm = (47 1/4")	
900mm = (35 1/2")	
600mm = (23 5/8")	
300mm = (11 7/8")	

--- Wire running under carpet

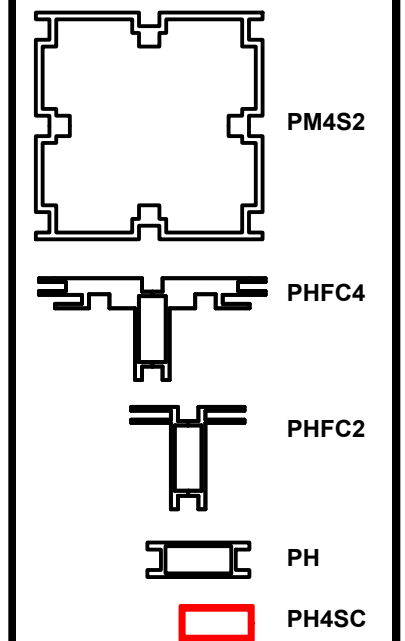

HYBRID PRO RENTAL KIT

Title: SET-UP INSTRUCTIONS

Code	#	Description
CUSTOM FS	1	APPROXIMATELY 8' X 10' X 8' CUSTOM FABRIC STRUCTURE - TO PACK INT

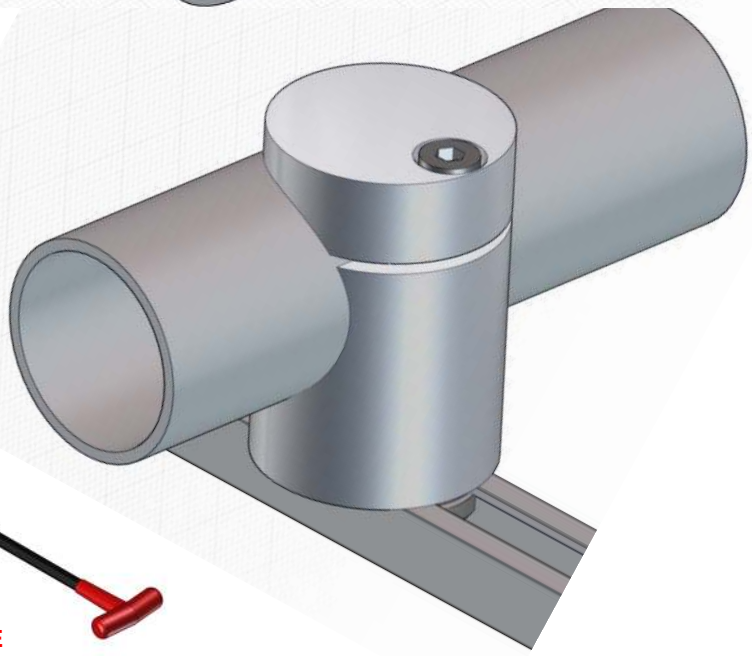
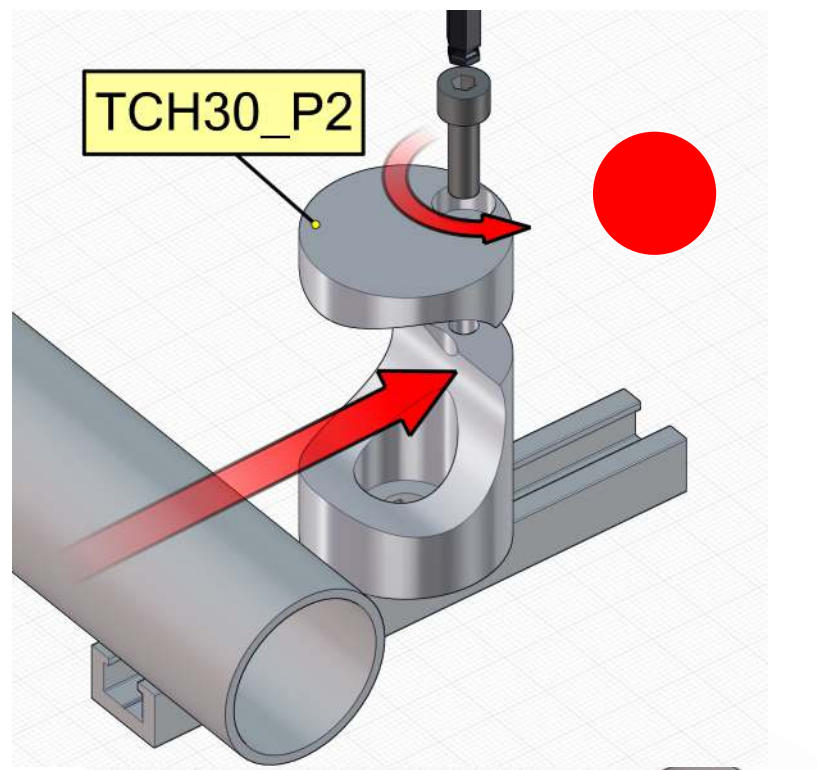
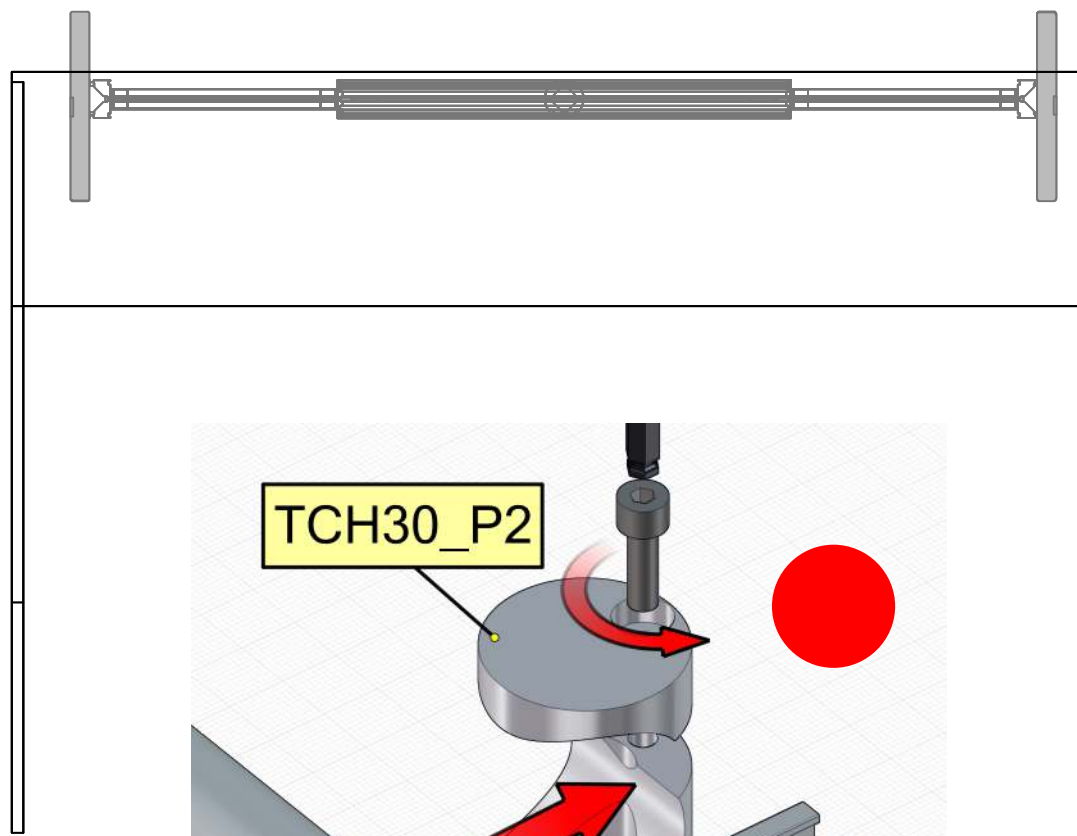
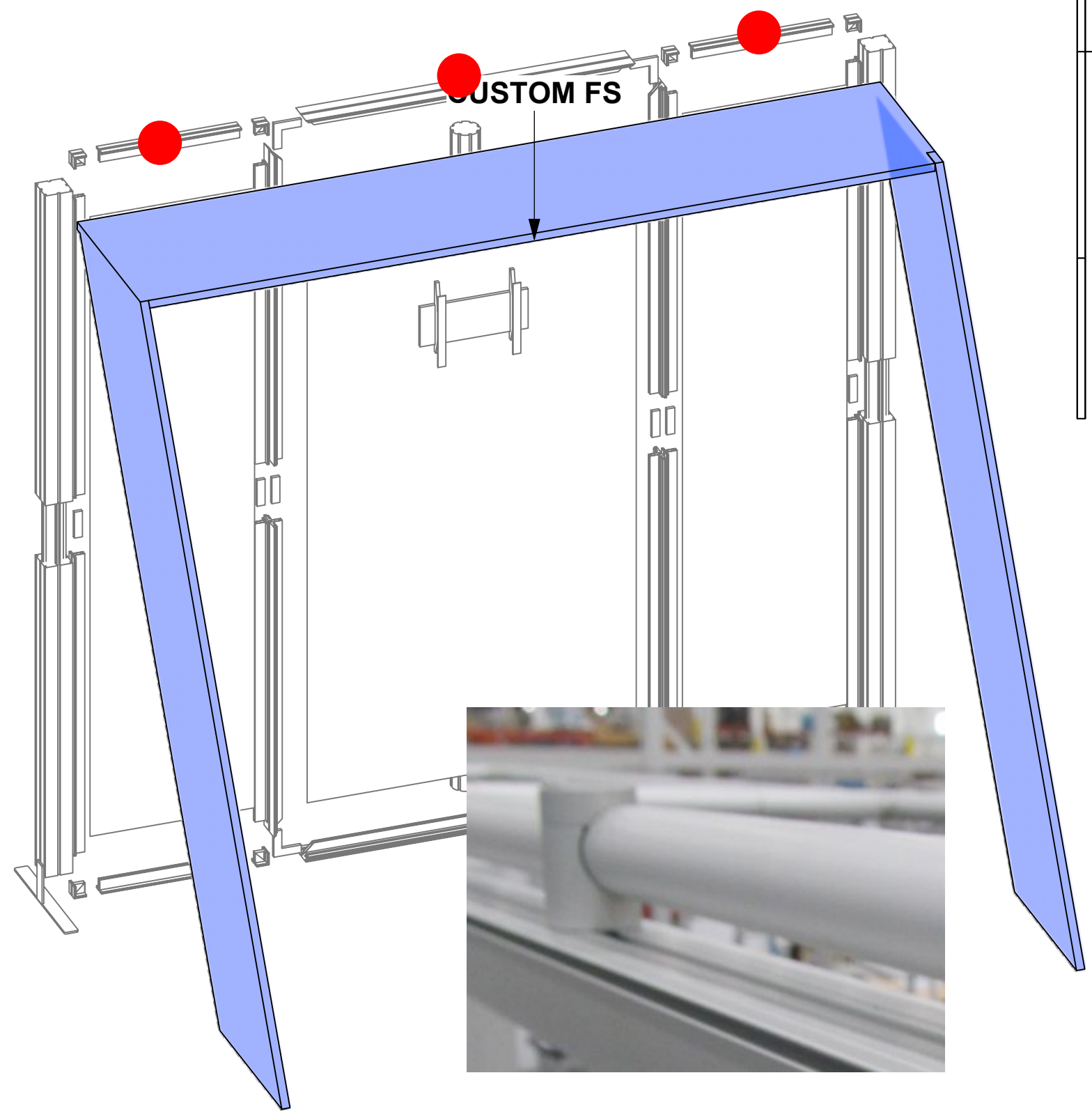

5MM T HANDLE

1. Redesign of this exhibit without approval by manufacturer may result in dangerous and unsafe structures. Manufacturer disclaims any responsibility for redesigned exhibits it does not approve in writing.

2. Parts and components such as panels and structures are manufactured to metric sizing. Where ever possible sizes have been noted in feet and inches as well as in metric. Below is the imperial to metric sizing table as reference. "Nominal" refers to approximate size.

2400mm = (94 1/2")	Phone Line / Fax
2100mm = (82 5/8")	Internet connection
1800mm = (70 7/8")	Outlet
1500mm = (59")	Main Drop (point of distrution)
1200mm = (47 1/4")	
900mm = (35 1/2")	
600mm = (23 5/8")	
300mm = (11 7/8")	

--- Wire running under carpet

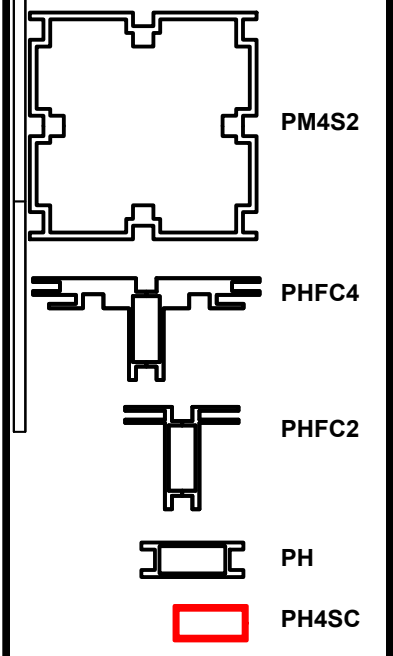

HYBRID PRO RENTAL KIT

Title: SET-UP INSTRUCTIONS

PACKING INSTRUCTIONS

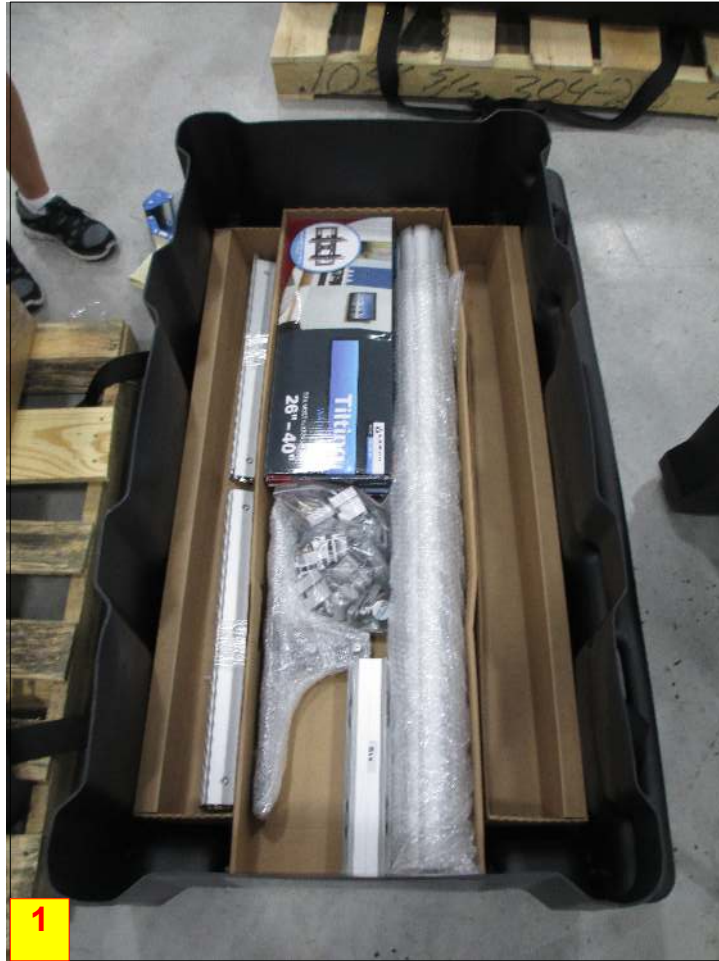

(1) MM-MB, (2) SW FOOT, (1) R14,
(1) R12, (4) R55
HARDWARE BOX

(8) R15, (1) R12, (2) R13

(8) R19, (3) R27,(2) R9

(1) R27, HARDWARE ITEMS

CASE # 1

LEGEND		GREY FOAM FOLDED TO FILL EMPTY SPACES OR USED AS PROTECTION
		1/8" CARDBOARD SPACER (PUT IN BETWEEN EVERY PANEL)
		DIVIDER
		1/4" WHITE FOAM (USED AS PROTECTION DOOR PANELS W/ LOCKS)

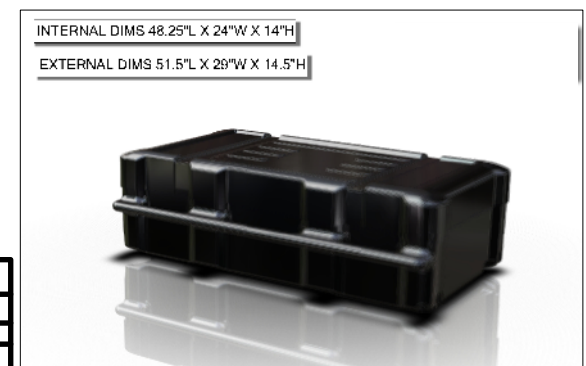



FABRIC STRUCTURE

CASE # 2

LEGEND		GREY FOAM FOLDED TO FILL EMPTY SPACES OR USED AS PROTECTION
		1/8" CARDBOARD SPACER (PUT IN BETWEEN EVERY PANEL)
		DIVIDER
		1/4" WHITE FOAM (USED AS PROTECTION DOOR PANELS W/ LOCKS)

INTERNAL DIMS 11" w X 14" h X 38" d
EXTERNAL DIMS 18" w X 17" h X 39" d

Monitor Bracket Instructions

Tube Applications



TUBE-SM-MB
Sizes: 23" - 42"
Max weight varies per application



TUBE-M-MB
Sizes: 32" - 55"
Max weight varies per application



TUBE-LG-MB
Sizes: 37" - 70"
Max weight varies per application

Included hardware:

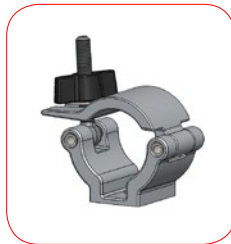

ACC60 x2



TCH-30 x2

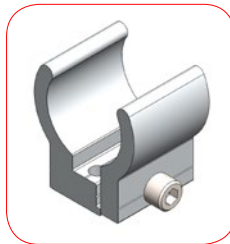

TC-30MM-SILVER x2

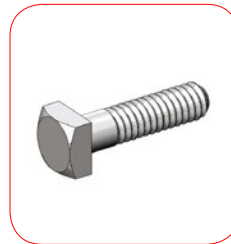

BOLT-1 x4

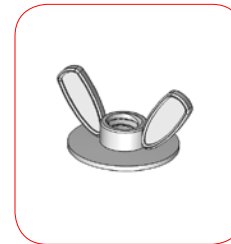

Flange Wingnut x4

TUBE CONNECTION

ACC60 Clamp Connection

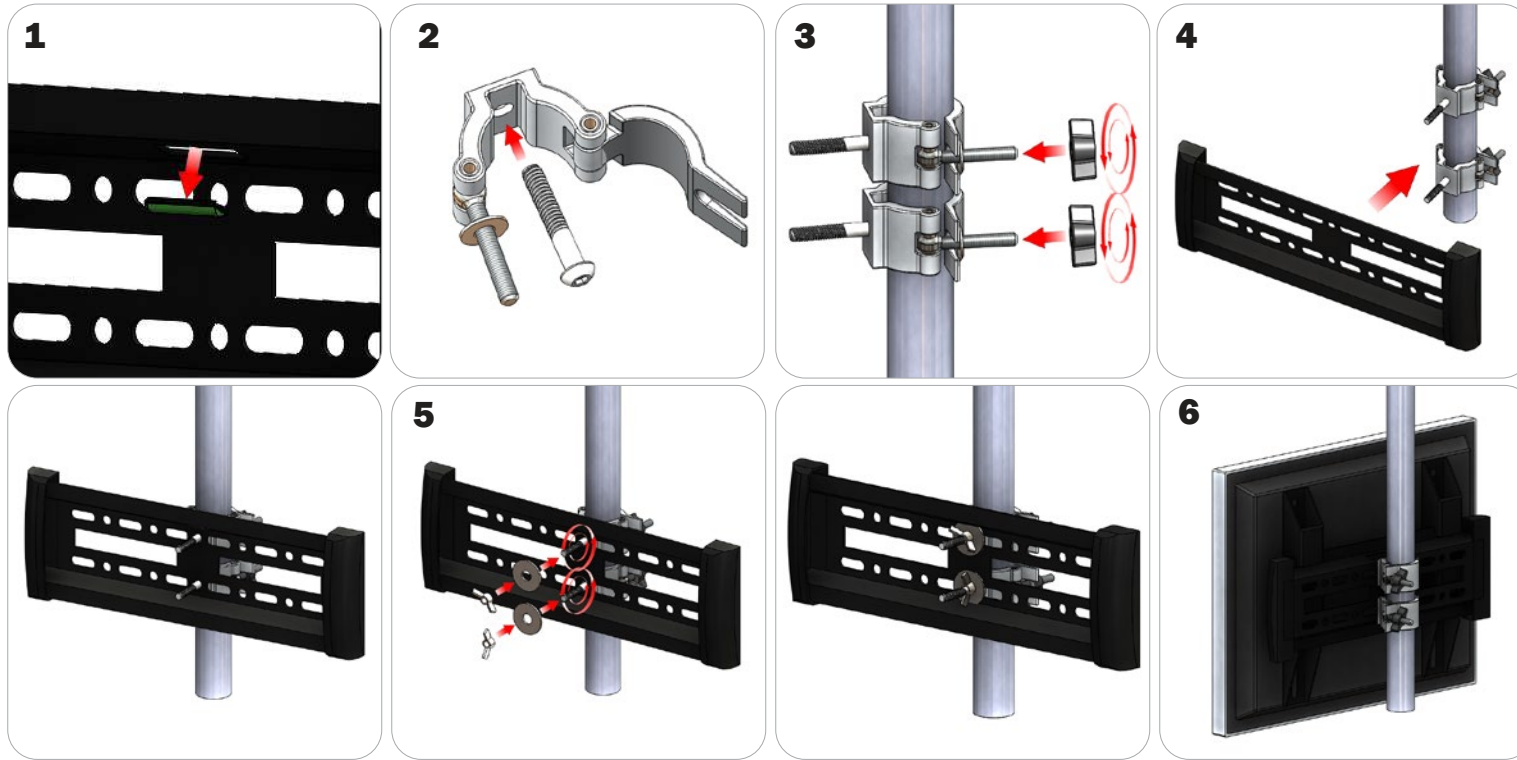

Locate all components needed to assemble the monitor mount with the ACC60 tube method. You will need (1) monitor bracket, (2) ACC60 clamps, (2) washers, and (2) wingnuts. **Step 1:** Apply pressure to the rear side of the leveling gauge clipped into the monitor mount to remove it. **Step 2:** Push the provided bolt through the hole in the ACC60 and place the ACC60 in the desired location. **Step 3:** Tighten the clamp to the tube using the plastic wingnut. **Step 4:** Set your monitor bracket onto the protruding bolts using the of the ACC60 using the center holes on the monitor bracket., adjust ACC60 position if necessary. **Step 5:** Lock your monitor bracket to the ACC60s by placing your washers and locking with provided wingnuts. **Step 6:** Reference the included manufacturer monitor mount instructions for fastening your monitor to the bracket.

TCH Clamp Connection (Tablet Stands)

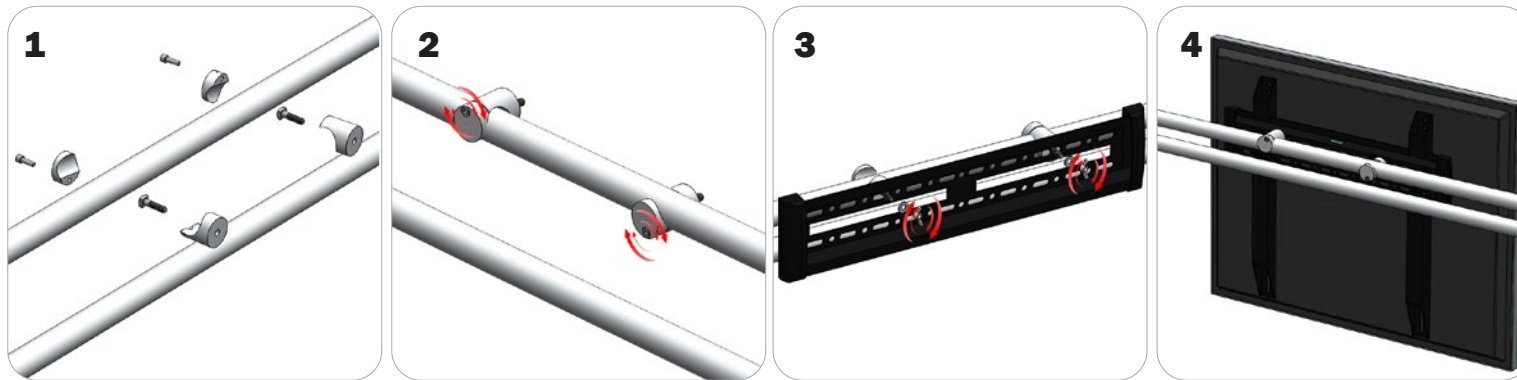

Locate all components needed to assemble the monitor mount with the TCH tube method. You will need (1) monitor bracket, (2) TCH clamps, (2) bolts, (2) washers, and (2) wingnuts. Determine your desired monitor location. **Step 1:** Fit the provided bolts through the TCH clamps then reassemble the clamp. **Step 2:** Lock the clamp onto the tube with the allen head screws on the clamp. **Step 3:** Align your monitor bracket so that the left and right holes slide onto the bolts behind them. Use your washers and wingnuts to lock your monitor bracket in place. **Step 4:** Reference the included manufacturer monitor mount instructions for fastening your monitor to the bracket.

TUBE CONNECTION

TC-30 Clamp Connection

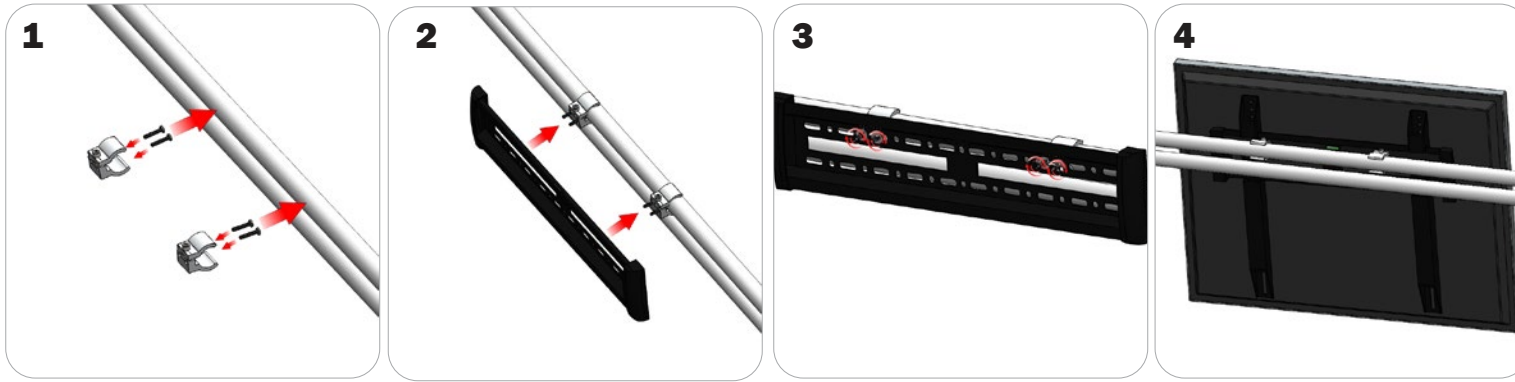

Locate all components needed to assemble the monitor mount with the TC-30 tube clamp method. You will need (1) monitor bracket, (2) TC-30-SILVER clamps, (4) BOLT-1 screws, and (4) flange wingnuts. **Step 1:** Insert the pan-head screws through the holes of your TC-30 clamps. Attach the TC-30 clamps to the tubes but do not tighten. **Step 2:** Set your monitor bracket onto the protruding pan-head screws on your clamps using the holes in the monitor bracket. **Step 3:** Apply your flange wingnuts to the front of your monitor bracket to lock it to the clamps. Lock your clamps securely into place. **Step 4:** Reference the included manufacturer monitor mount instructions for fastening your monitor to the bracket.