

Hybrid Pro Modular Kit 09

HP-K-09

Hybrid Pro™ Modular exhibits and counters are a perfect solution for the serious exhibitor. Exhibits feature heavy-duty aluminum extrusion frames and push-fit fabric graphics. Count on making an unforgettable impact with Hybrid Pro Modular exhibit kits, counters, and accessories.



We are continually improving and modifying our product range and reserve the right to vary the specifications without prior notice. All dimensions and weights quoted are approximate and we accept no responsibility for variance. E&OE. See Graphic Templates for graphic bleed specifications.

features and benefits:

- Silver aluminum extrusion frame
- Illuminated graphic panel with interior top and bottom LED lighting
- Single-sided fabric graphics
- Easy step-by-step instructions
- Counter available in four thermoformed finishes, shown below
- Kit includes frame, five fabric graphic panels, two illuminated graphic panels, two tables, one counter, four spotlights, two small monitor mounts, three medium monitor mounts and three molded cases
- Lifetime hardware warranty against manufacturer defects

dimensions:

Hardware

Assembled unit:
228.38" w x 94.75" h x 40.13" d
5801mm(w) x 2407(h) x 1019mm(d)

Approximate weight:
324 lbs / 147 kg

Shipping

Packing case(s):
1 SCRATE
1 OCH2

Shipping dimensions:
SCRATE:
57" l x 59" h x 33" d
1448mm(l) x 1449mm(h) x 838mm(d)

OCH2:
52" l x 29" h x 15" d
1321mm(l) x 737mm(h) x 381mm(d)

Approximate total shipping weight:
503 lbs / 229 kg

Graphic

Refer to related graphic template for more information.

Visit:
<https://www.theexhibitorshandbook.com/download-graphic-templates>

additional information:

Graphic material:
Dye-sublimation SEG push-fit fabric

Table dimensions:
21" w x 40.5" h x 19.7" d
533mm(w) x 1029mm(h) x 500mm(d)

Tables holds max weight 25 lbs / 12 kg

Counter dimensions:
30.63" w x 40.5" h x 18.75" d
778mm(w) x 1029mm(h) x 476mm(d)

Counter holds max weight 50 lbs / 23 kg

Small monitor brackets hold 17-37" LCD, maximum weight: 40 lbs / 19 kg

Medium monitor bracket holds 32-55" LCD, maximum weight: 80 lbs / 37 kg

Tabletop Colors:

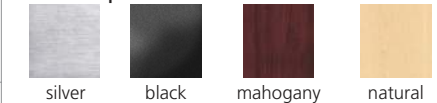

2 person assembly recommended:



This product may include the following materials for recycle:
aluminum, select wood, fabric, cardboard, paper, steel, and plastics.

Included In Your Kit

Tools, Components, & Connectors



HEX KEY SET x1



PHFC2-8R-20-L-L x8



PHFC2-1155-L-L1-SIDE x16



PHFC4-900-MCB9-MCB9 x6



PHFC4-1200-L1-MCB9 x12



PM4D-300-TG x1



PM4R8-1155-A165-L x2

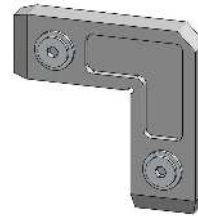

CB9 x12

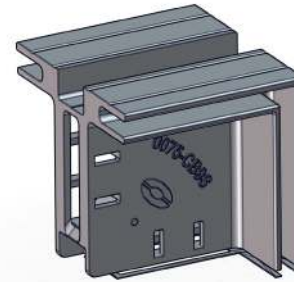

CB9-S x16

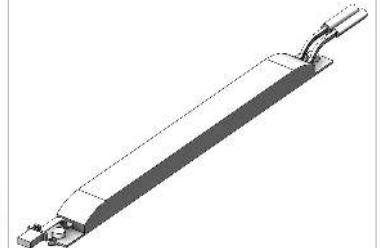

LED-DB-SUPLY-2 x2

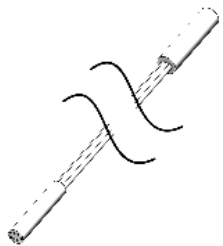

LED-DB-PWRSUPLY-2-CL-300 x2

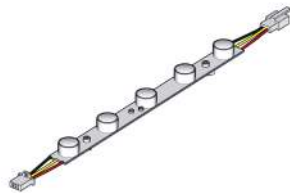

LED-WHT-DB-300 x32



IB2 x8



LUM-LED2-ORL-S x4

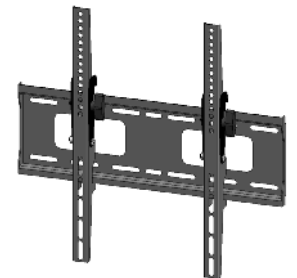

EXT-M-MB x1

Included In Your Kit

Tools, Components, & Connectors

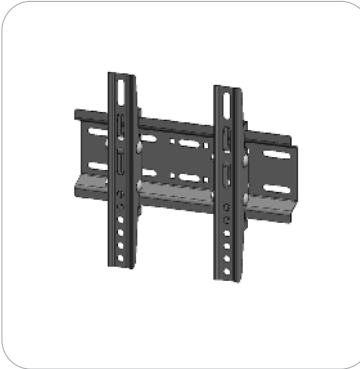

EXT-SM-MB x2

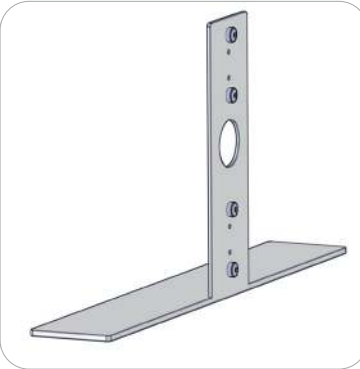

SW-FOOT-500-LN x6



LN114-S2-450 x4



PH4SC-300-TG x2



PM2S2-1200-A165-A165 x8

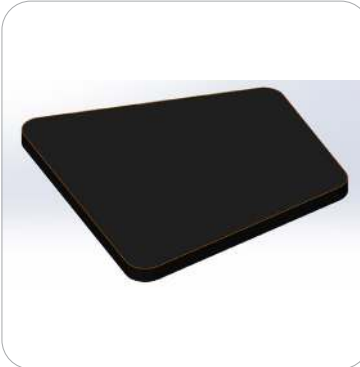

V-WS-12 x2



V-LG-05 x2

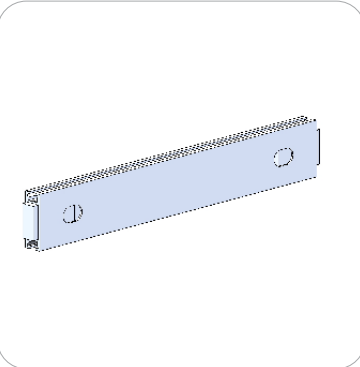

PH-300-S-S x2

Included In Your Kit

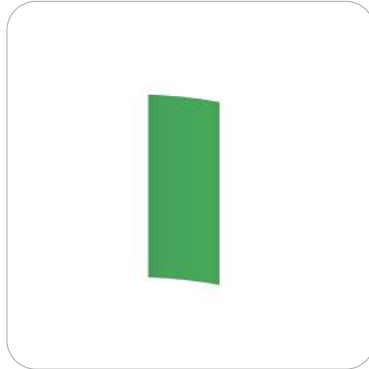

A1 x1



A2 x1

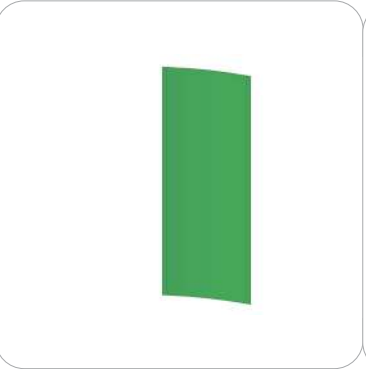

A3 x1

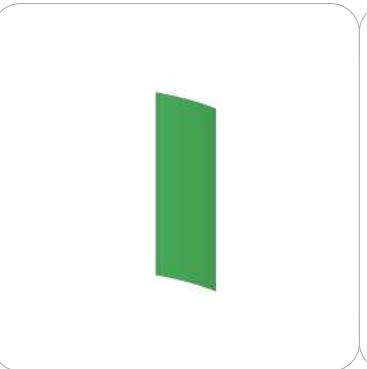

A4 x1

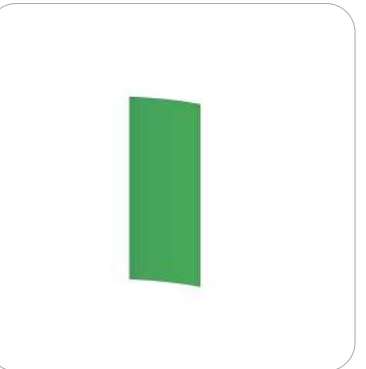

GRAPHIC C x1

Graphics



B2 x1

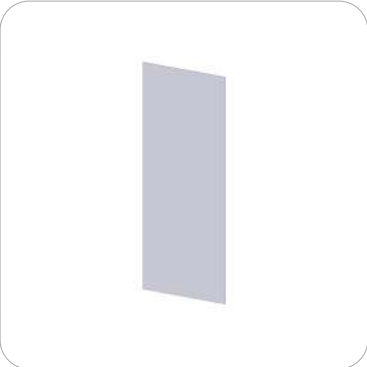

UNPRINTED B x1

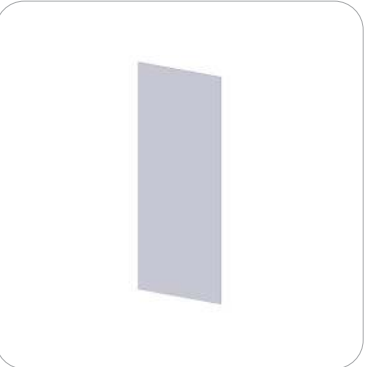

UNPRINTED B2 x1

Exploded View

HP-K-09

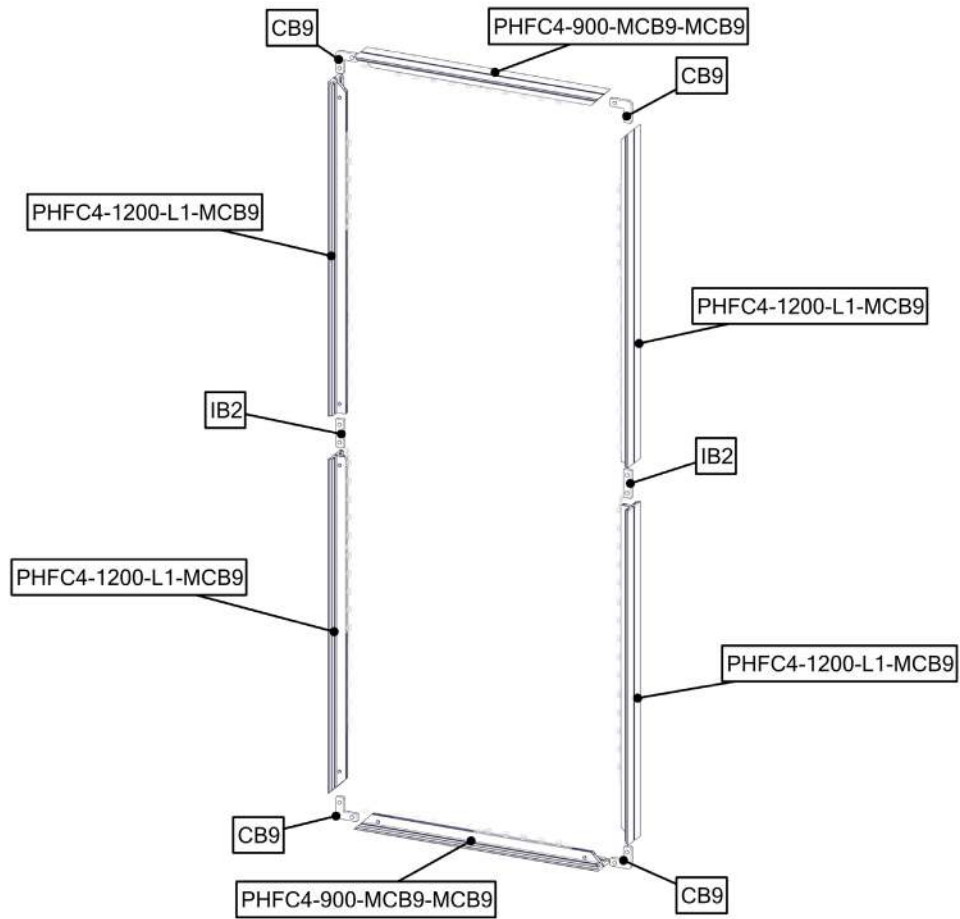

-ASSEMBLE LEFT SIDE MAIN FRAME

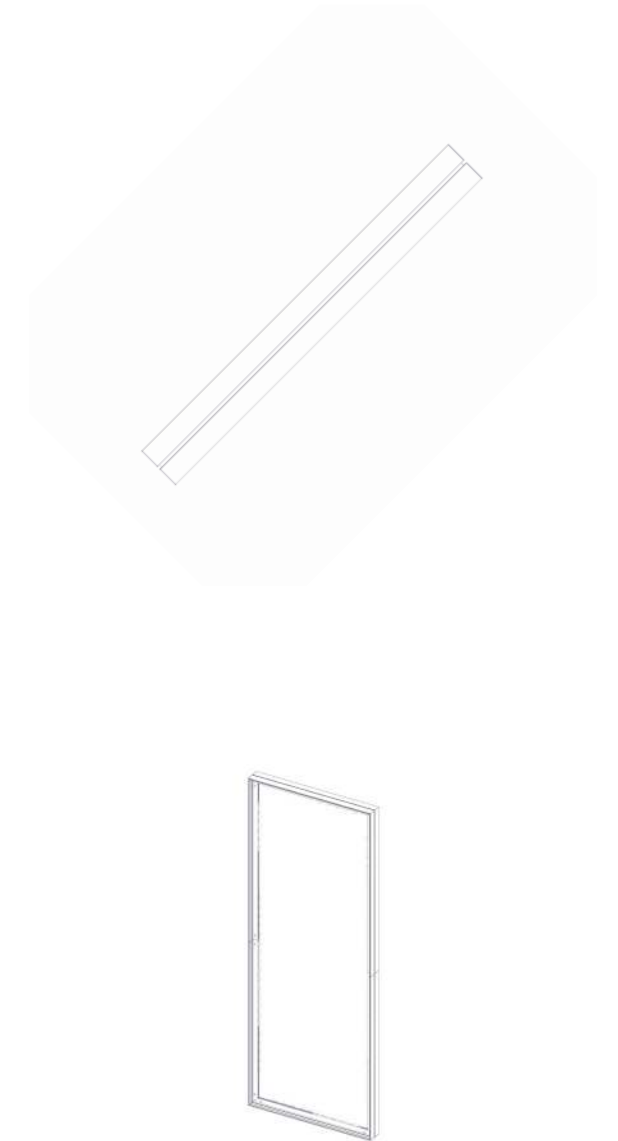

Lighting Diagram

HP-K-09

-LIGHTING DIAGRAM FOR LEFT & RIGHT SIDE LIGHT BOX

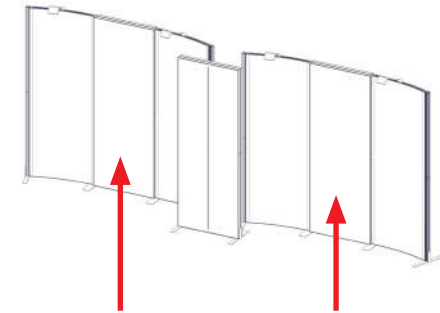
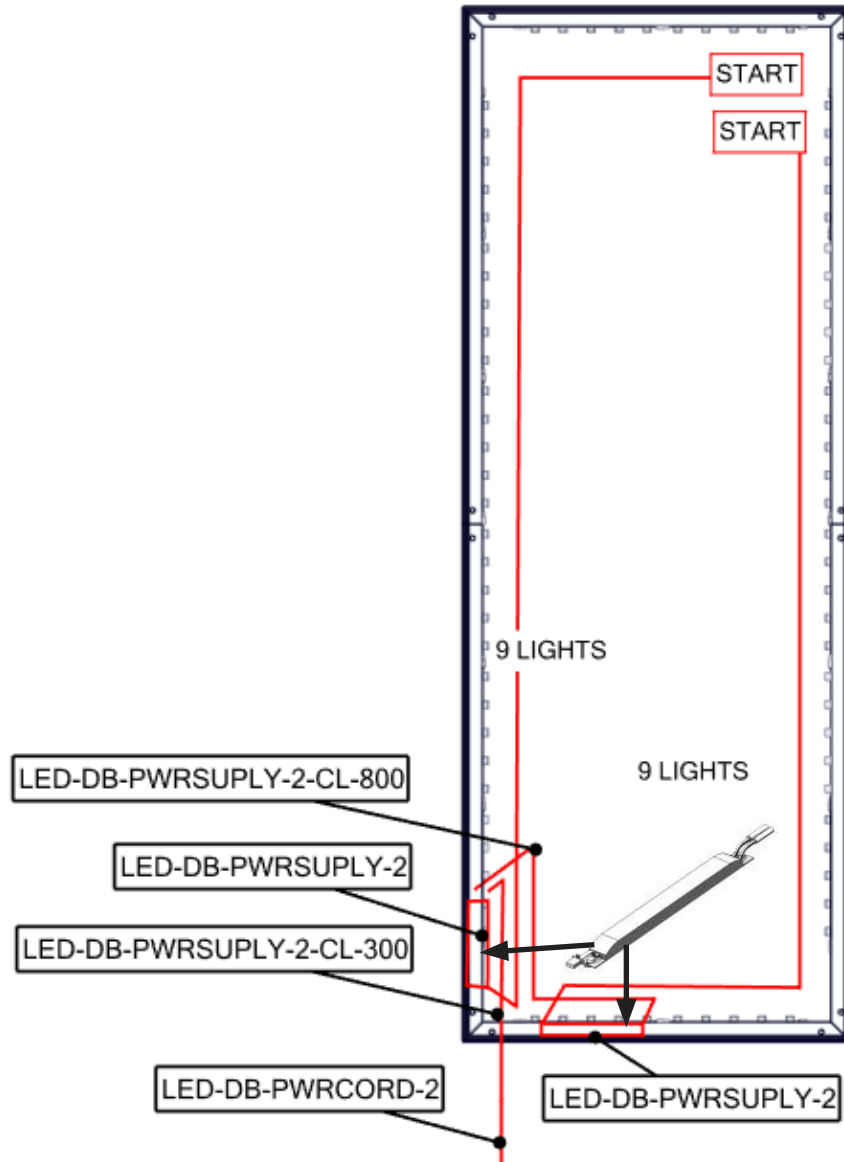

LEFT & RIGHT SIDE LIGHT BOX

Exploded View

HP-K-09

-ATTACH TO MAIN FRAME

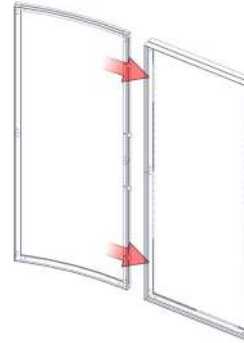
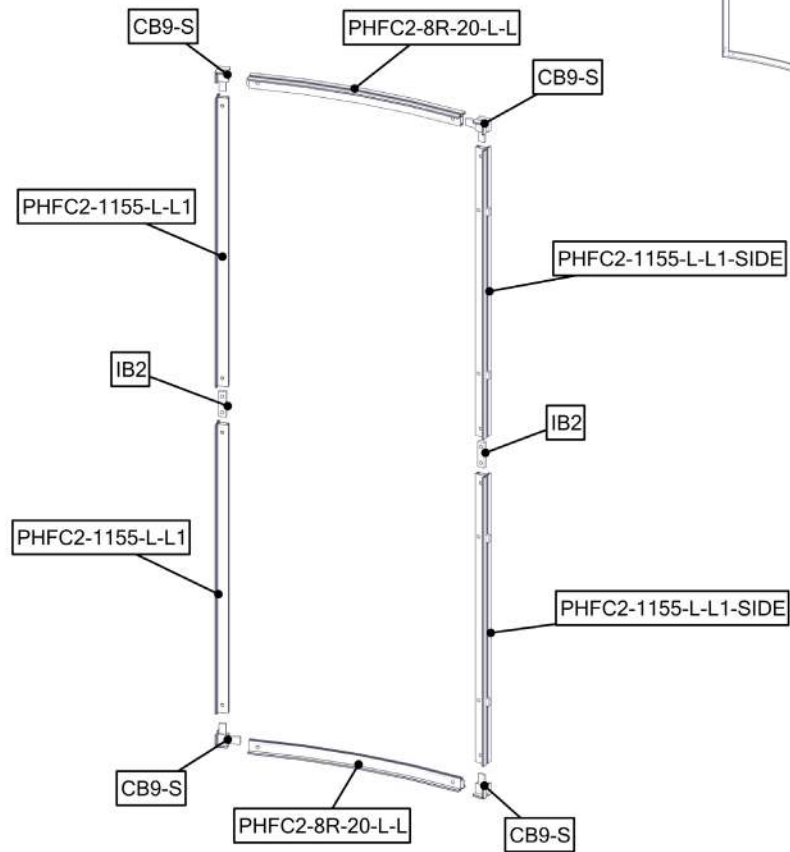

-ASSEMBLE LEFT SIDE LEFT WING FRAME

Labeling Diagram

HP-K-09

-ATTACH TO MAIN FRAME

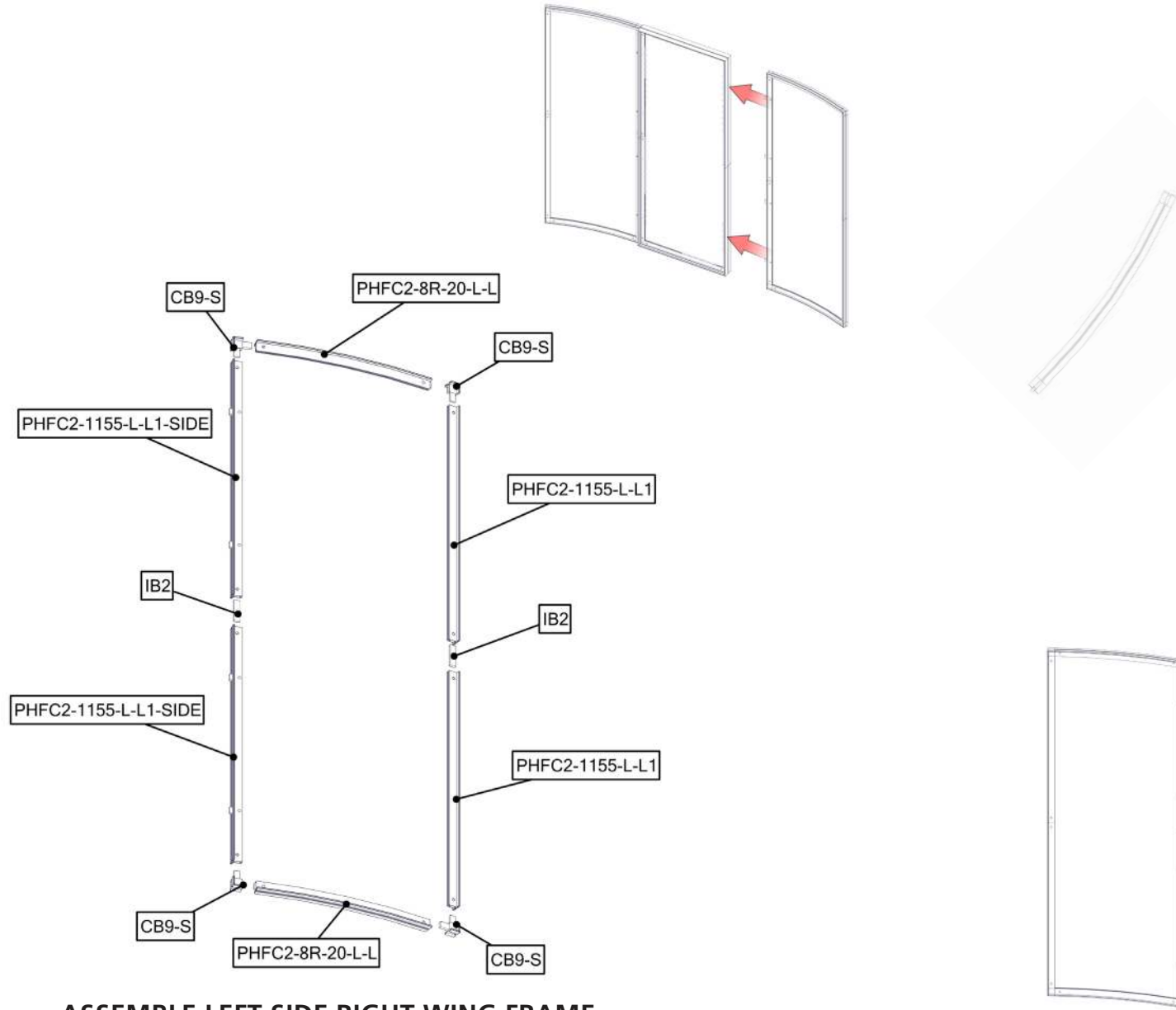

Labeling Diagram

HP-K-09

-ATTACH TO MAIN FRAME

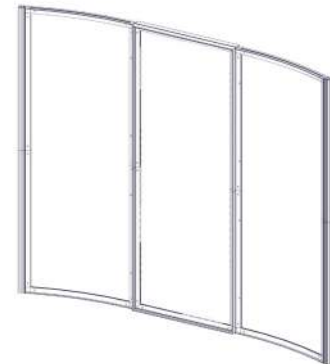
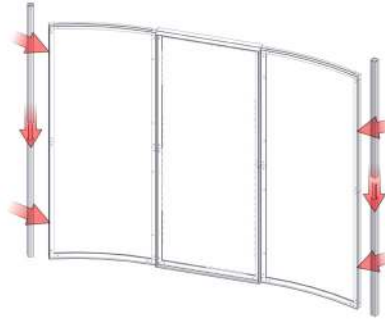

PM2S2-1200-A165

PH4-300-TG

PM2S2-1200-A165

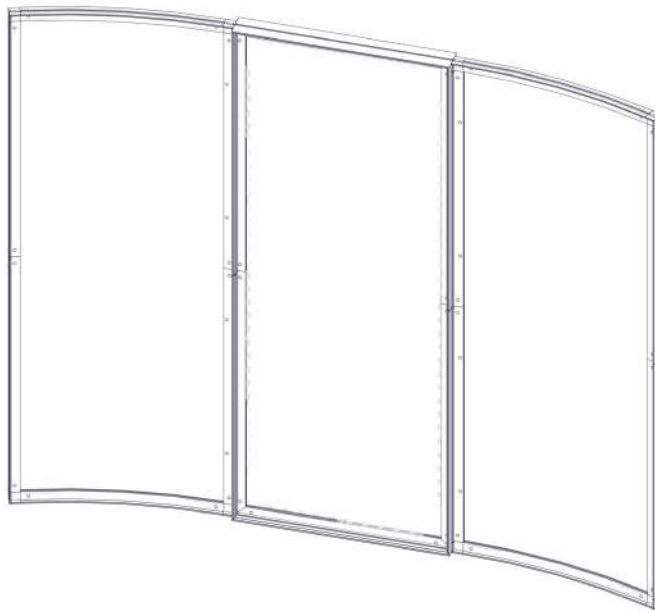

PM2S2-1200-A165

PH4-300-TG

PM2S2-1200-A165

-ASSEMBLE LEFT SIDE FRAME SUPPORTS

Labeling Diagram

HP-K-09

-ATTACH TO MAIN FRAME

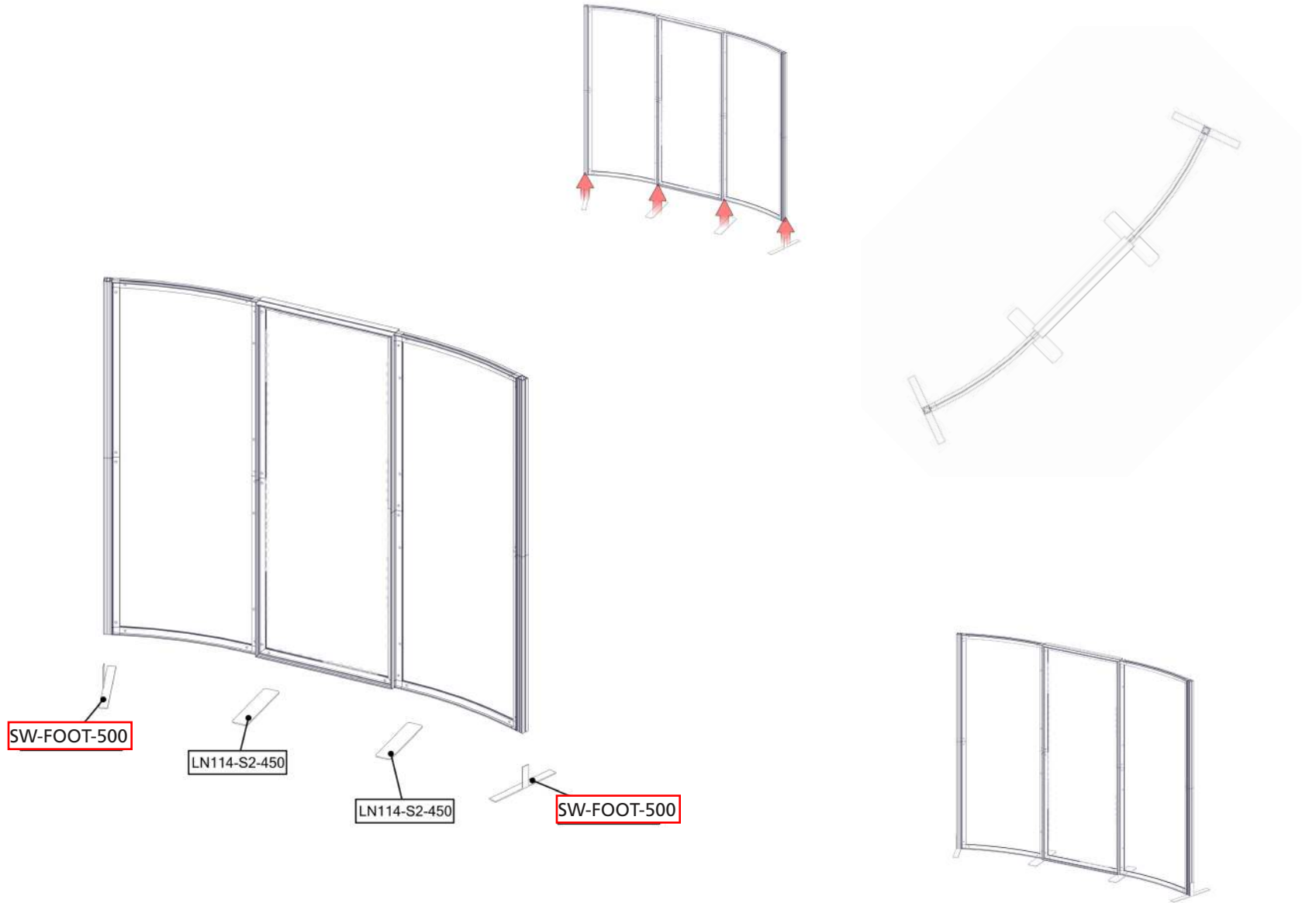

-ATTACH LEFT SIDE FRAME BASE

Labeling Diagram

HP-K-09

-ATTACH TO MAIN FRAME

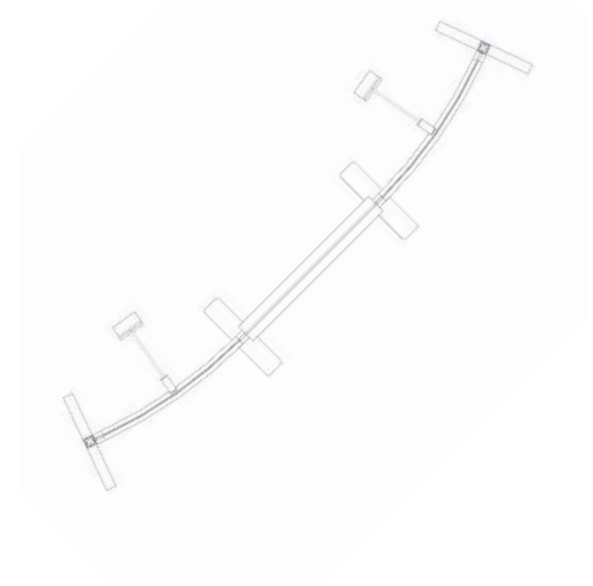
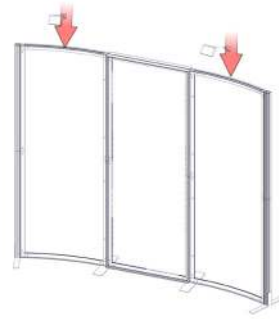

LUM-LED2-ORL-S

LUM-LED2-ORL-S

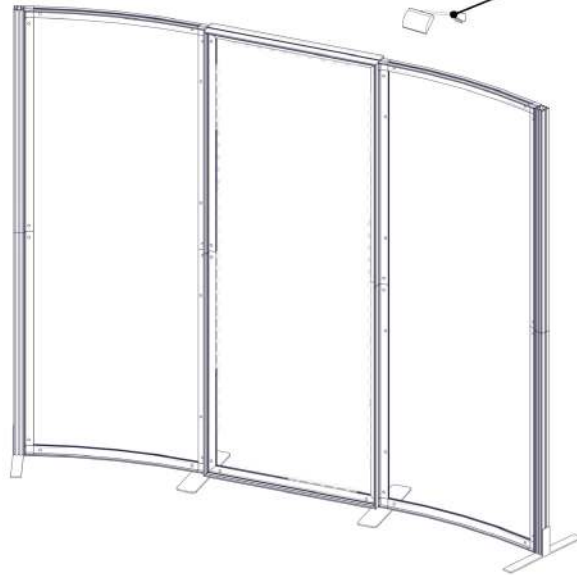

-ATTACH LIGHT TO TOP OF FRAME

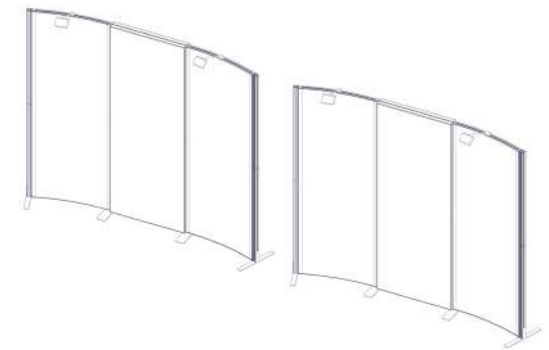

REPEAT THE SAME PROCESS TO ASSEMBLE THE RIGHT SIDE FRAME

Labeling Diagram

HP-K-09

-ATTACH GRAPHICS
FRONT & REAR

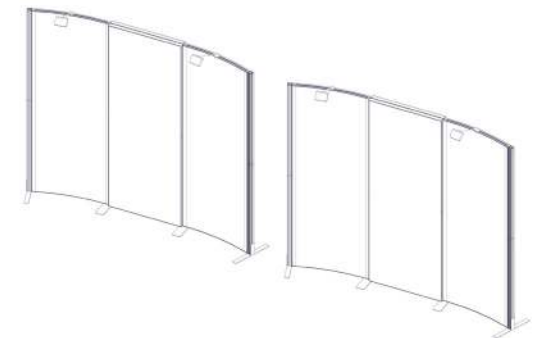
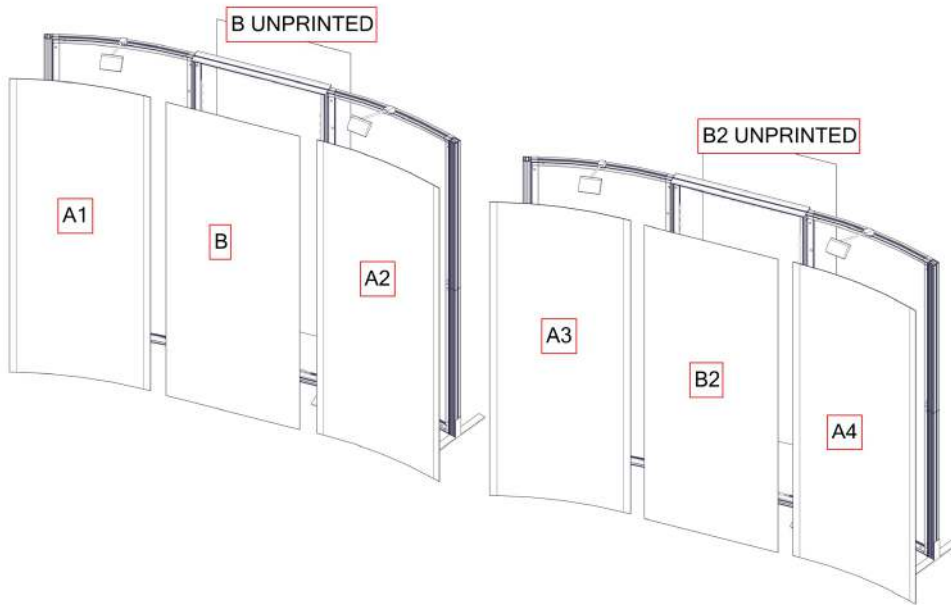
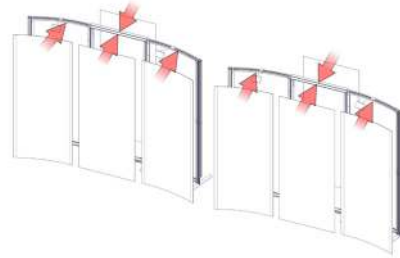

-ATTACH LEFT & RIGHT FRAME GRAPHICS

Labeling Diagram

HP-K-09

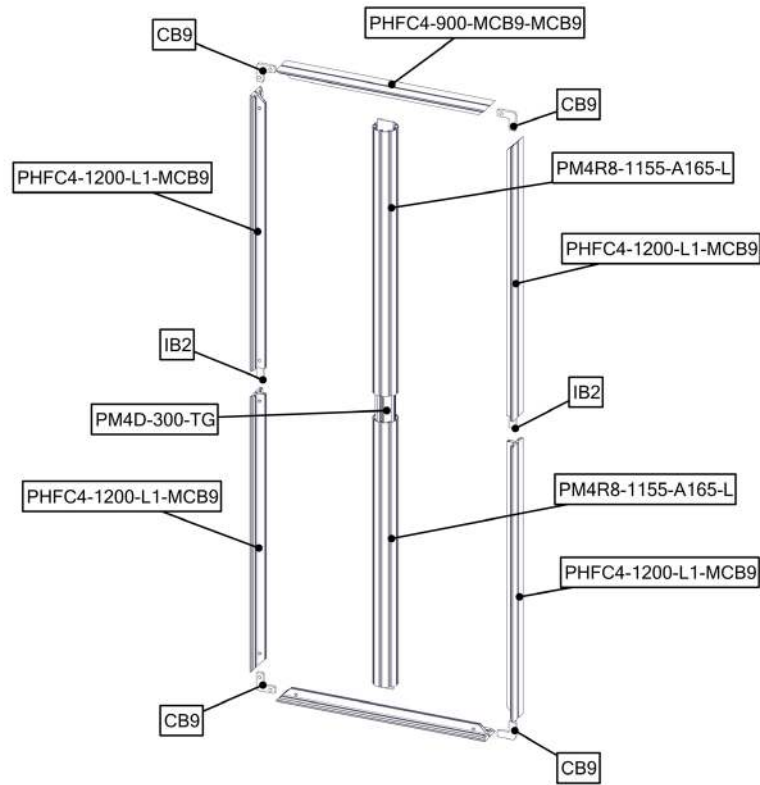

-ASSEMBLE FRONT CENTER FRAME

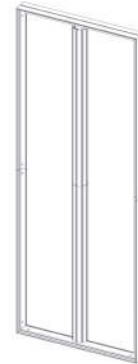
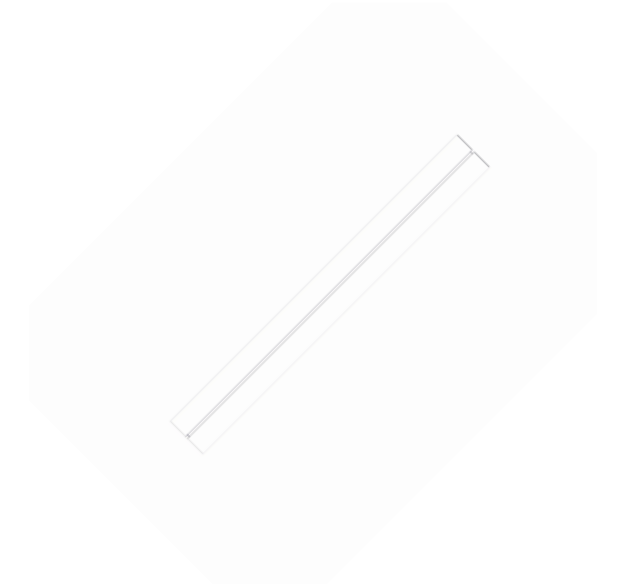

Labeling Diagram

HP-K-09

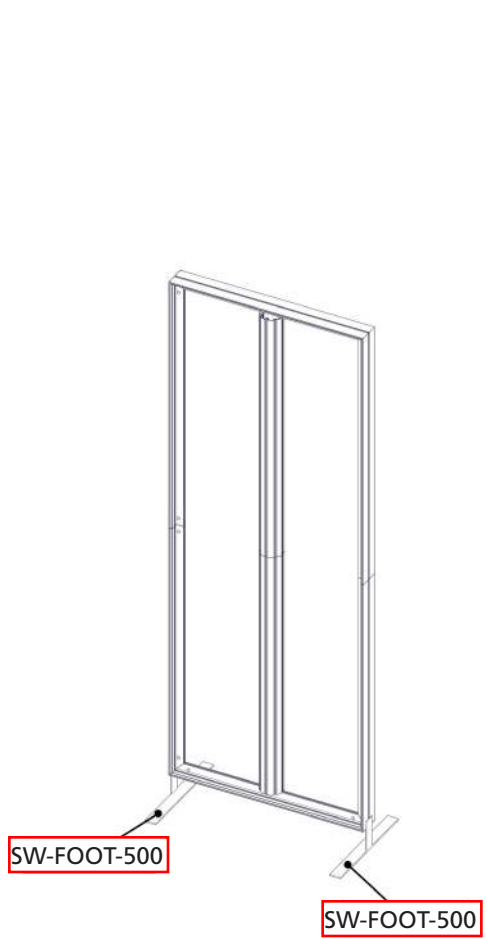

-ATTACH FRAME BASE

Labeling Diagram

HP-K-09

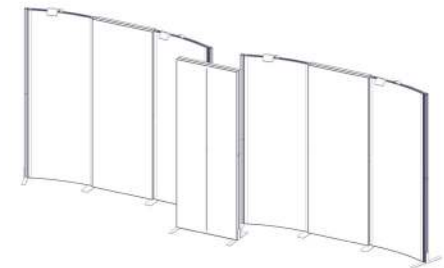
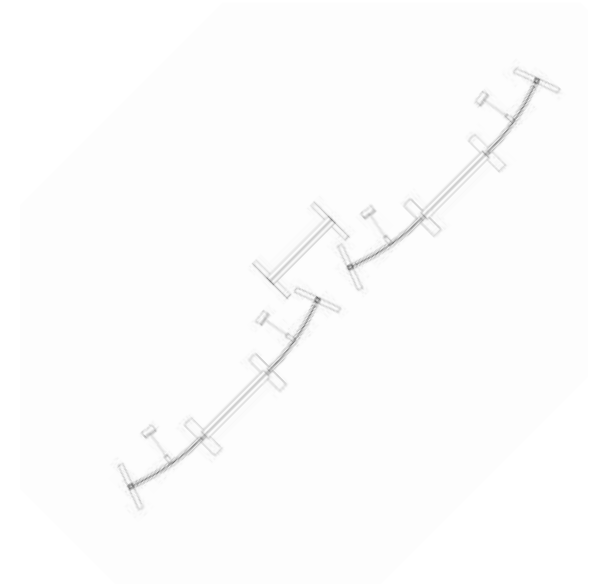
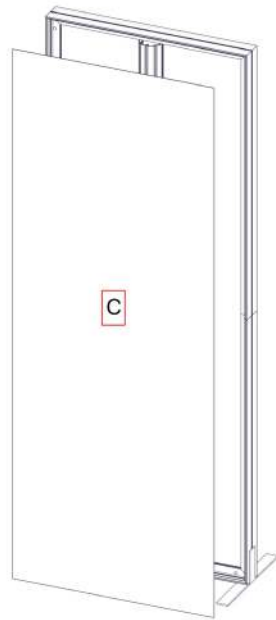

-ATTACH FRONT FRAME GRAPHIC

Labeling Diagram

HP-K-09

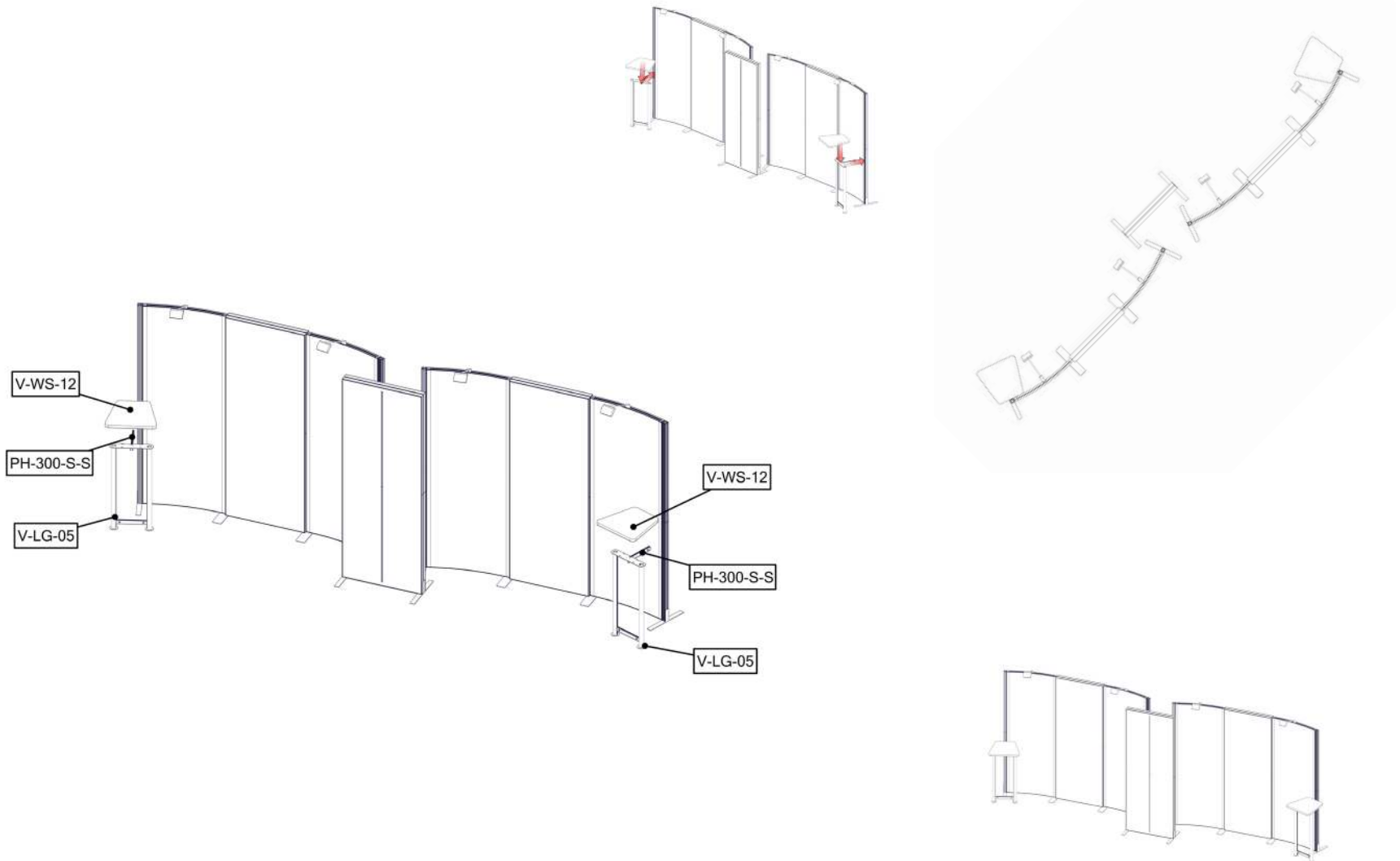

-ASSEMBLE

Labeling Diagram

HP-K-09

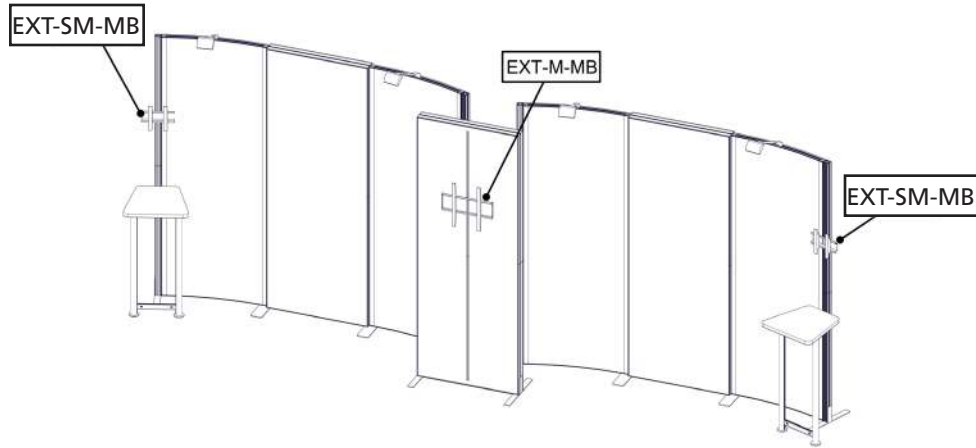
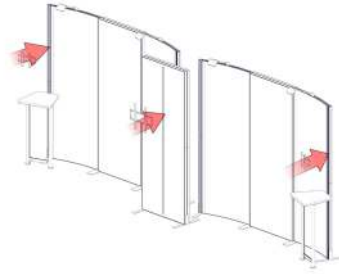

-ASSEMBLE

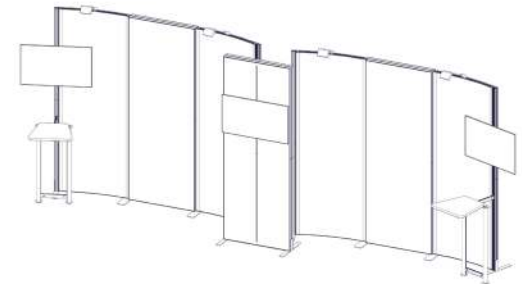

Labeling Diagram

HP-K-09

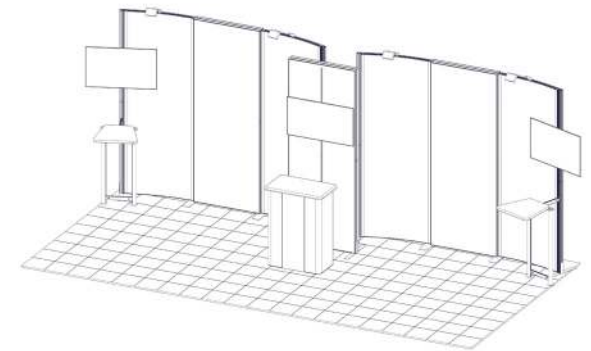
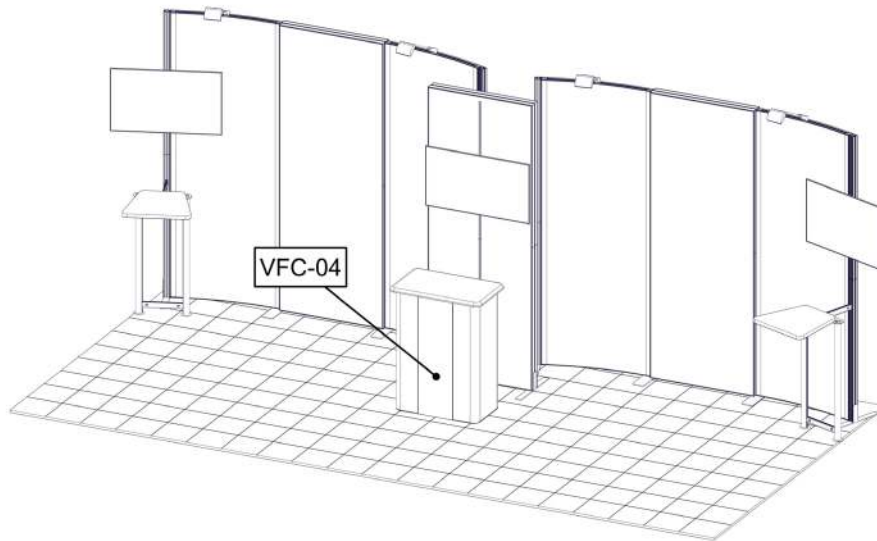

**-PLACEMENT OF VFC-04
PDF WITH DETAIL INSTRUCTIONS ON
ASSEMBLE FOLLOW THIS PAGE**

Over -Head Layout

HP-K-09

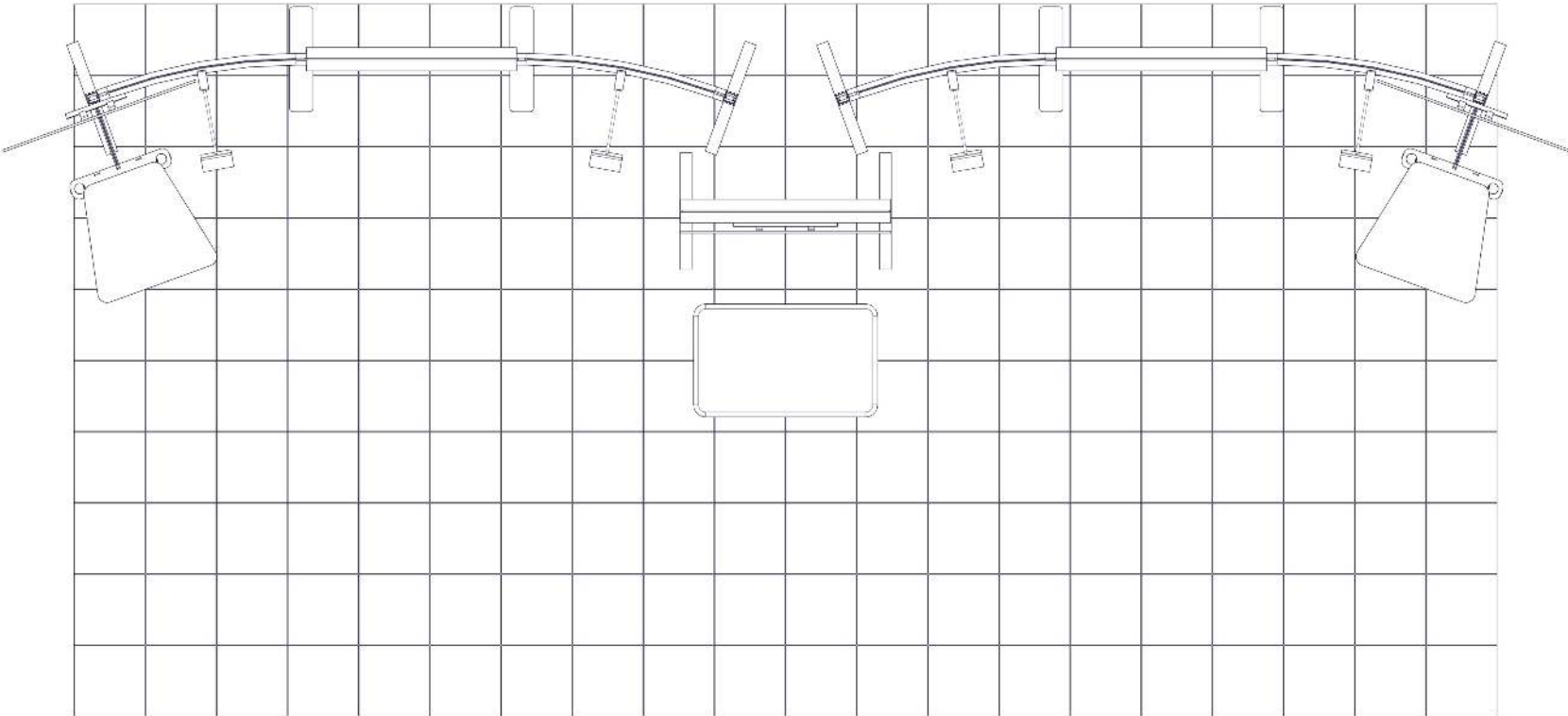

Kit Assembly

Step by Step

Step 1.

Gather the components to build the frame. Use the Exploded View and the Labeling Diagram for part labels.

Reference Connection Method(s) 1 and 2 for more details.



Step 2.

Gather the components to build the frame. Use the Exploded View and the Labeling Diagram for part labels.

Reference Connection Method(s) 3 and 6 for more details.



Step 3.

Gather the components to build the frame. Use the Exploded View and the Labeling Diagram for part labels.

Reference Connection Method(s) 3 and 6 for more details.



Step 4.

Connect frames. Use the Exploded View and the Labeling Diagram for part labels.

Reference Connection Method(s) 4 for more details.

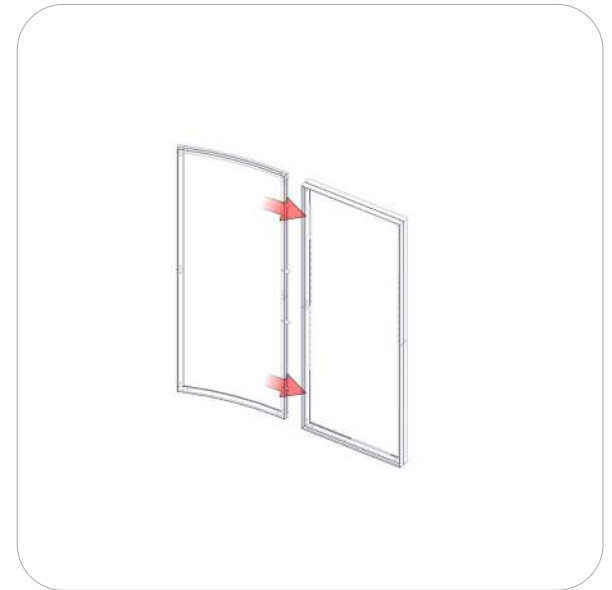

Kit Assembly

Step by Step

Step 5.

Connect frames. Use the Exploded View and the Labeling Diagram for part labels.

Reference Connection Method(s) 4 for more details.

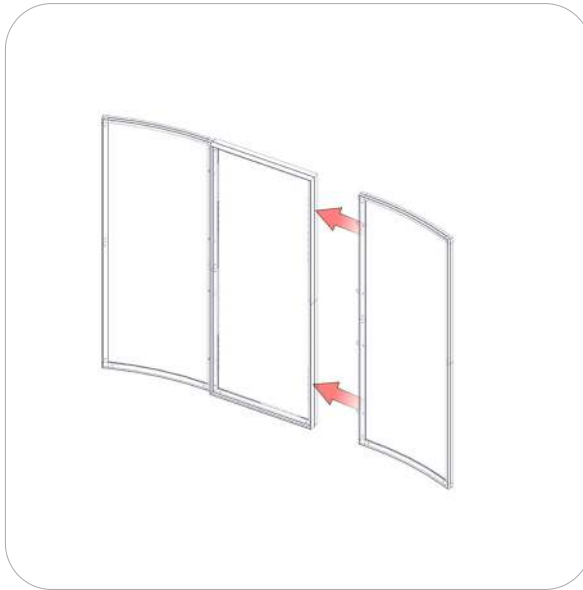

Step 6.

Attach PM252 side supports to both sides.. Use the Exploded View and the Labeling Diagram for part labels.

Reference Connection Method(s) 4 and 12 for more details.

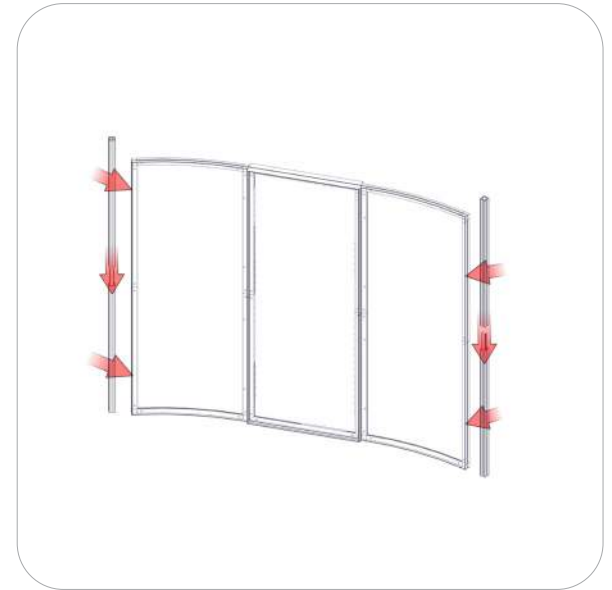

Step 7.

Attach frame SW-FOOT for stability. Use the Exploded View and the Labeling Diagram for part labels.

Reference Connection Method(s) 7 and 8 for more details.

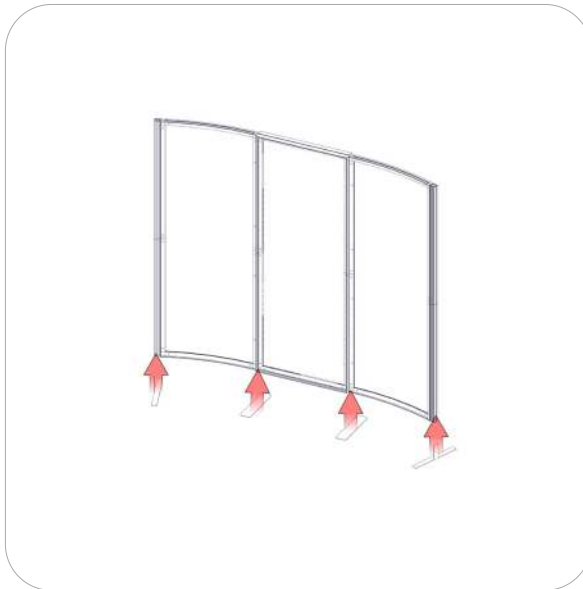

Step 8.

Attach light fixtures to the top of frame. Use the Exploded View and the Labeling Diagram for part labels.

Reference Connection Method(s) 17 for more details.

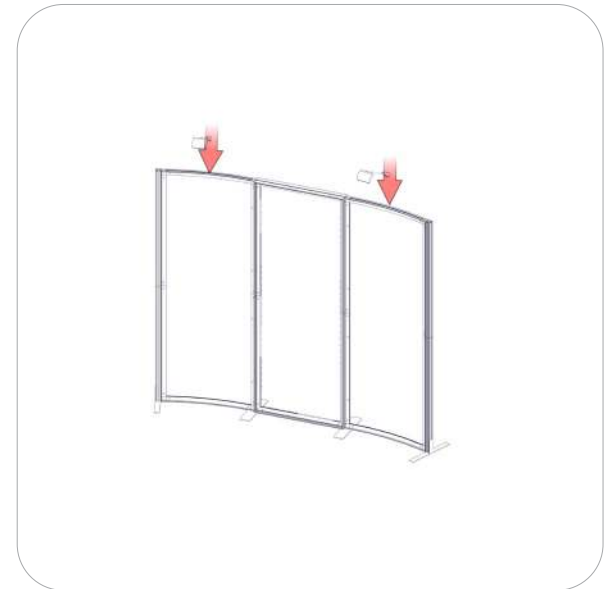

Kit Assembly

Step by Step

Step 9.

Apply graphics to frame. Use the Exploded View and the Labeling Diagram for part labels.

Reference Connection Method(s) 9 for more details.

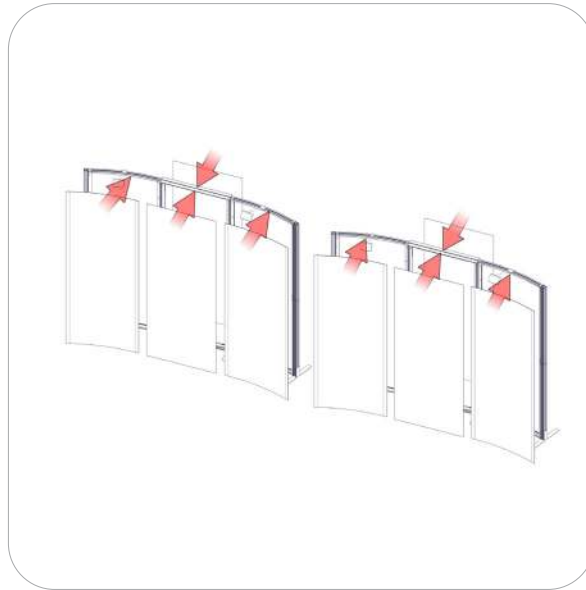
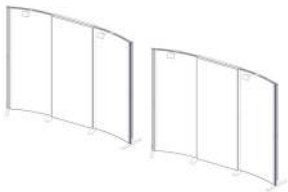

Step 10.

Assemble front frame. Use the Exploded View and the Labeling Diagram for part labels.

Reference Connection Method(s) 14 and 16 for more details.



Step 11.

Attach frame SW-FOOT for stability. Use the Exploded View and the Labeling Diagram for part labels.

Reference Connection Method(s) 8 for more details.



Step 12.

Apply graphics to frame. Use the Exploded View and the Labeling Diagram for part labels.

Reference Connection Method(s) 9 for more details.

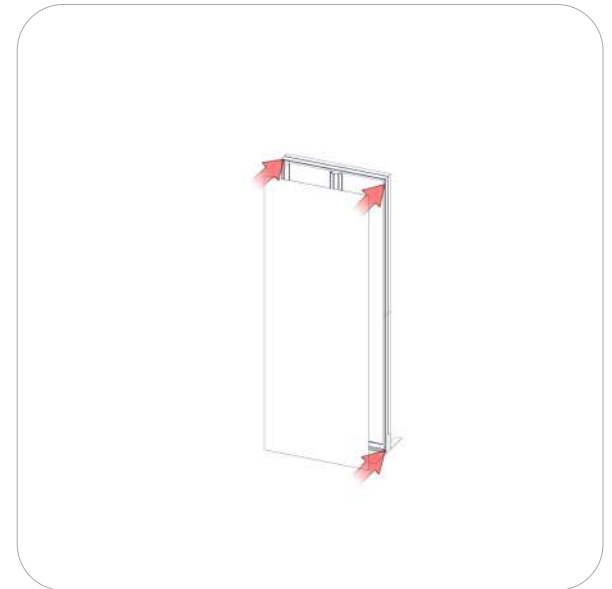

Kit Assembly

Step by Step

Step 13.

Gather the components needed to assemble work table. Use the Exploded View and the Labeling Diagram for part labels.

Reference Connection Method(s) 1, 2 and 3 for more details.

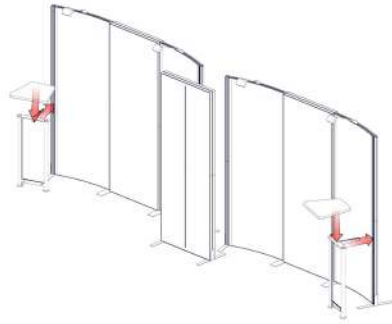
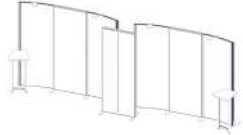

Step 14.

Attach monitor mounts. Use the Exploded View and the Labeling Diagram for part labels.

Reference Connection Method(s) 11 and 15 for more details.

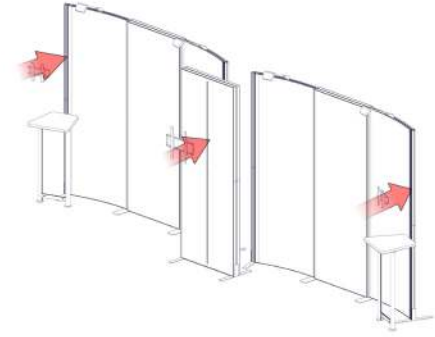
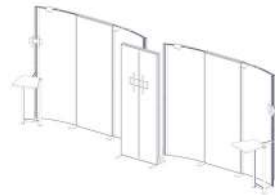

Step 15.

VFC-04. See Detailed PDF attached, with instructions on how to assemble.

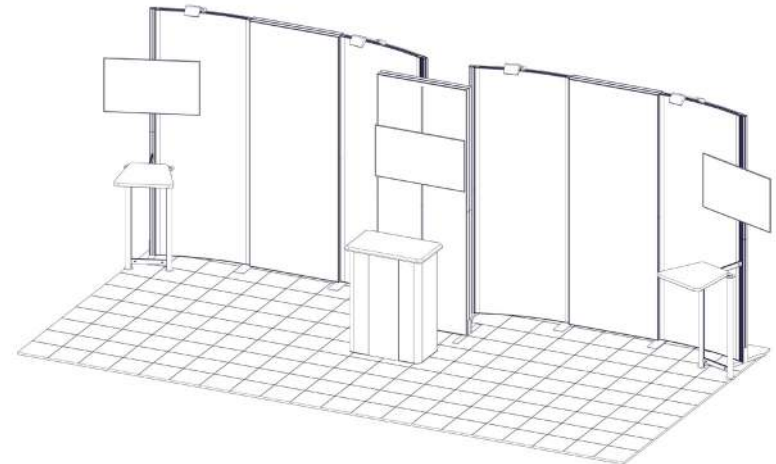
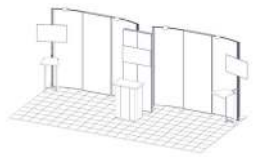

COMPLETE SETUP

Connection Methods

Connection Method 1: CB9



First, insert the corner connector into the extrusion while holding in the lock button with the allen key tool. Second, slide the next extrusion onto the same corner connector while holding in the lock button using the allen key tool. Third, use the allen key tool for locking the corner connector buttons in place. Use the allen key tool to make half turns clock-wise. Do not over tighten the lock buttons.

Connection Method 2: IB2



First, insert the in-line connector into the extrusion while holding in the lock button with the allen key tool. Second, slide the next extrusion onto the same in-line connector while holding in the lock button using the allen key tool. Third, use the allen key tool for locking the in-line connector buttons in place. Use the allen key tool to make half turns clock-wise. Do not over tighten the lock buttons.

Connection Method 3: CB9-S

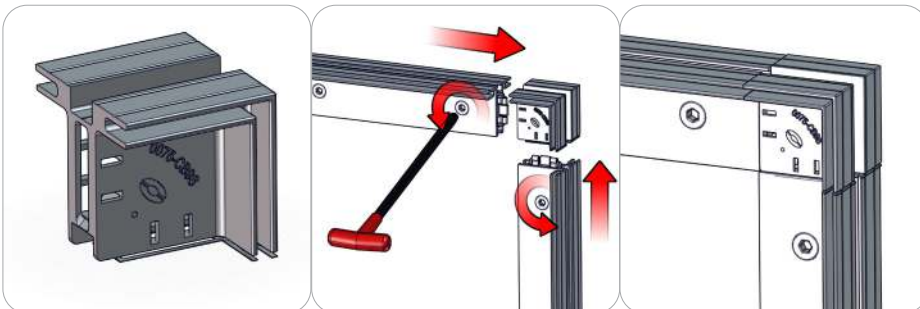

First, make sure the cam lock button is unlocked. Second, insert the cam lock teeth in to corner bracket channel. Third, tighten the cam lock button. Use the allen key tool to turn the lock buttons, make quarter turns and do not over tighten the lock buttons. Repeat for opposite end.

Connection Method 4: CAM LOCK

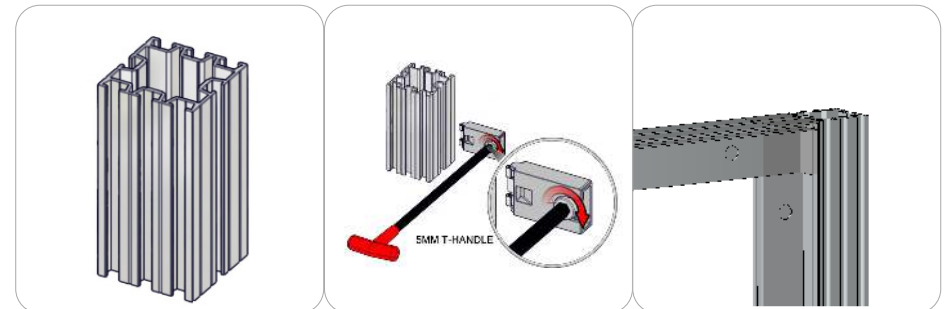

First, pull frame close together. Notice the PHFC2 has embedded CAM LOCKS on sides. Second, make sure CAM LOCKS IS loosed to fix into PM2S2 channel. Use the allen key tool to make half turns clock-wise. Do not over tighten the lock buttons.

Connection Methods

Connection Method 5: CB9/PHFC2



First, insert the corner connector into the extrusion while holding in the lock button with the allen key tool. Second, slide the next extrusion onto the same corner connector while holding in the lock button using the allen key tool. Third, use the allen key tool for locking the corner connector buttons in place. Use the allen key tool to make half turns clock-wise. Do not over tighten the lock buttons.

Connection Method 6: IB2/PHFC2

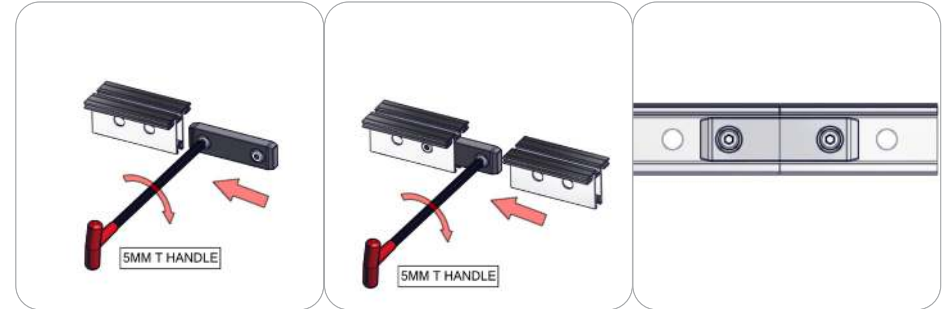

First, insert the in-line connector into the extrusion while holding in the lock button with the allen key tool. Second, slide the next extrusion onto the same in-line connector while holding in the lock button using the allen key tool. Third, use the allen key tool for locking the in-line connector buttons in place. Use the allen key tool to make half turns clock-wise. Do not over tighten the lock buttons.

Connection Method 7: LN114-S2-450

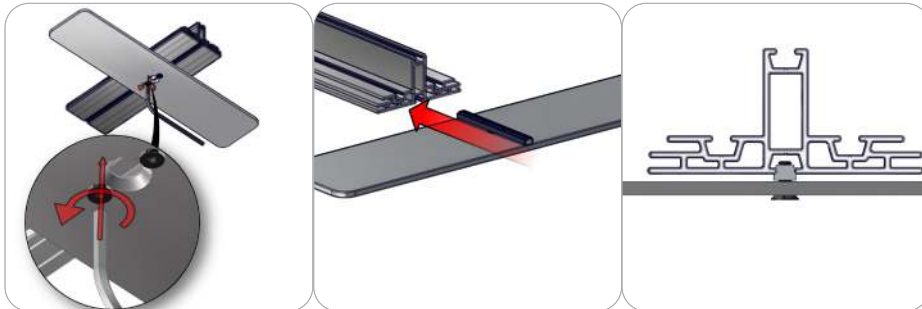

First, loosen the screws and channel bar on the stabilizing base. Do not disassemble them. Second, slide channel bar into the frame channel flush with the base of the frame. Third, tighten the screws and channel bar securing the attachment. Do not over tighten the screws.
(tools not included for this step)

Connection Method 8: SW-FOOT-500

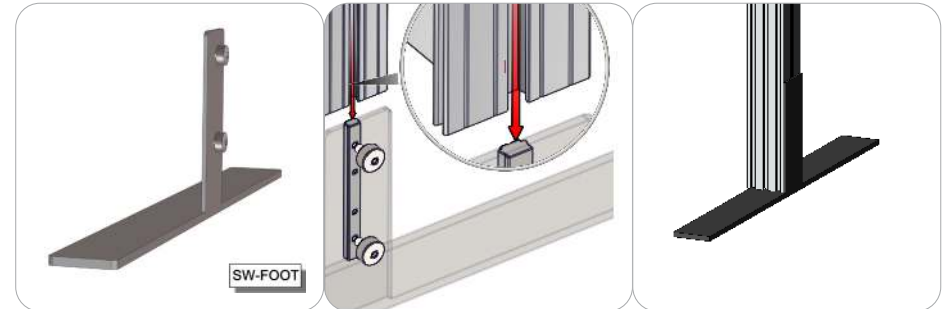

First, loosen the thumb screws and channel bars on the stabilizing bases. Do not disassemble them. Second, slide channel bars into the frame channel flush with the base of the frame. Third, tighten the thumb screws and channel bars securing the attachment. Do not over tighten the thumb screws.

Connection Methods

Connection Method 9: Graphic Application

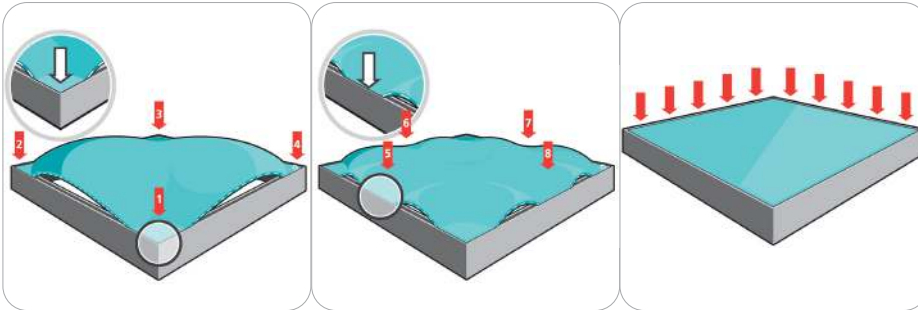

First, insert the silicone edge frame corners into the frame graphic channel (points 1 through 4). Second, insert the silicone edge frame sides into the frame graphic channel (points 5 through 8). Third, push the remaining silicone edge fabric into the frame graphic channel. Similar setup is recommended for the opaque liner. To remove these panels, simply pull the loop tag sewn near a corner.

Connection Method 10: PM4DSC

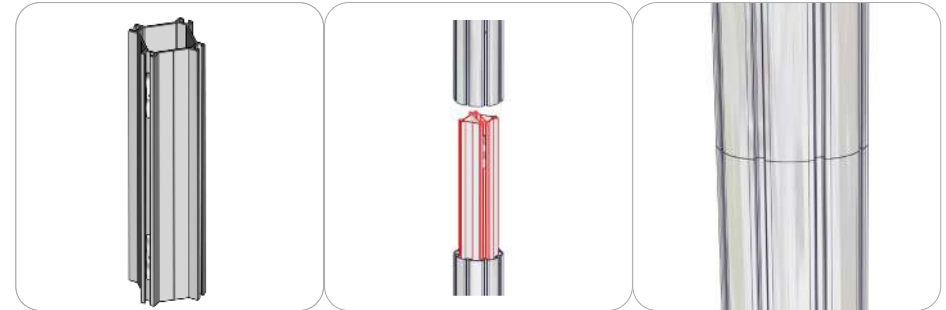

First, take the PM4DSC connector and align it with the internal channels of the next extrusion. Second, slide the connector into the inside channels of the extrusion. The tension glides on the connector will keep it center and snug. The extrusion will have stop pins pre installed to stop it from sinking in. Third, take the next extrusion and apply it on top of the connector completing your connection.

Connection Method 11: PH1/PM2S2



First, with the cam lock disengaged, place the cam lock teeth into the extrusion channel. Second, use the allen key tool to lock it in place. Make half turns clock-wise to engage the cam lock. Do not over tighten the lock buttons.

Connection Method 12: PH4/ PM2S2

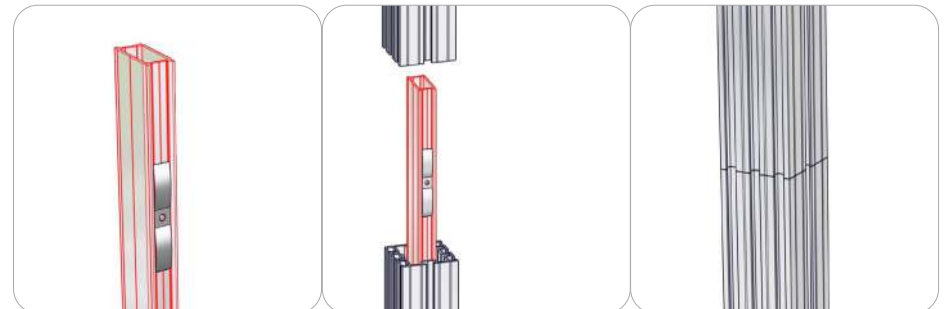

First, take the PH4SC connector and align it with the internal channels of the next extrusion. Second, slide the connector into the inside channels of the extrusion. The tension glides on the connector will keep it center and snug. The extrusion will have stop pins pre installed to stop it from sinking in. Third, take the next extrusion and apply it on top of the connector completing your connection.

Connection Methods

Connection Method 13: PH1/PM2S2

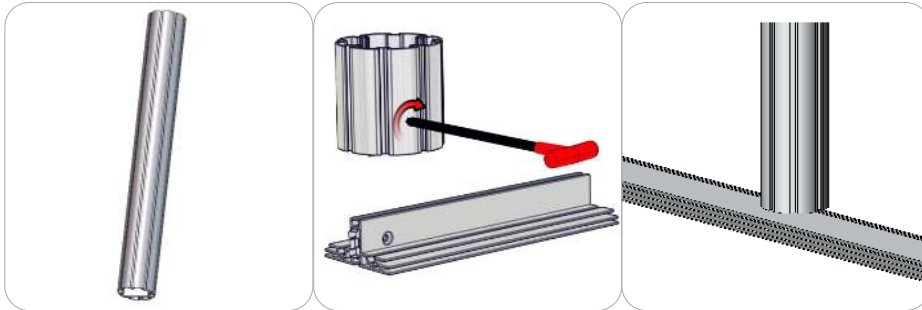

First, with the cam lock disengaged PM4R8, place the cam lock teeth into the PHFC4 extrusion channel. Second, use the allen key tool to lock it in place. Make half turns clock-wise to engage the cam lock. Do not over tighten the lock buttons.

Connection Method 14: Counter Legs with thumb screw

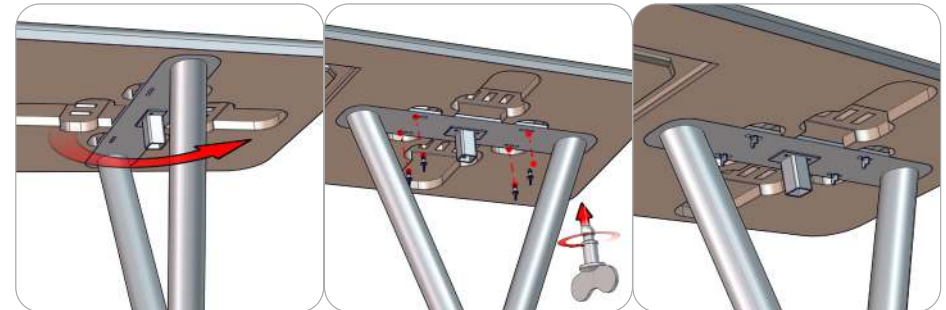

First, choose an orientation for the counter leg to be positioned on the under side of the counter top. With the counter leg in place, use the thumb screws to fasten the top plate of the leg onto the underside of the counter top. Do not over tighten.

Connection Method 15: LUM-LED2-ORL-S



First, slide light clip onto the lights. Second, then slide the light into the channel at an angle and then gently lower down.

Monitor Bracket Instructions

Extrusion Channel Applications

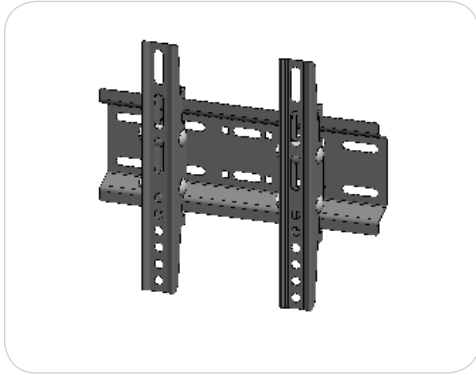

EXT-SM-MB

**Vesa Pattern: 75 x 75
up to 200 x 200mm**

Max weight varies per application

Assembled unit:

10" w x 8.86" h x 2" d
255mm (w) x 225mm (h) x 50mm (d)

Shipping dimensions:

14" l x 6" h x 4" d
356mm (l) x 152mm (h) x 102mm (d)

Approximate total shipping weight:

6 lbs / 3 kg

Recommended monitor sizes:

23" - 42"

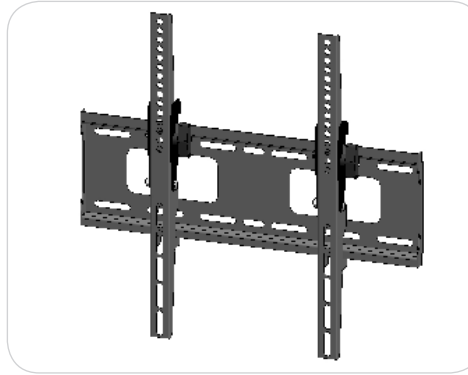

EXT-M-MB

**Vesa Pattern: 200 x 200
up to 400 x 400mm**

Max weight varies per application

Assembled unit:

17.6" w x 16.7" h x 1.6" d
448mm (w) x 425mm (h) x 40mm (d)

Shipping dimensions:

24" l x 4" h x 4" d
610mm (l) x 102mm (h) x 102mm (d)

Approximate total shipping weight:

8 lbs / 4 kg

Recommended monitor sizes:

32" - 55"

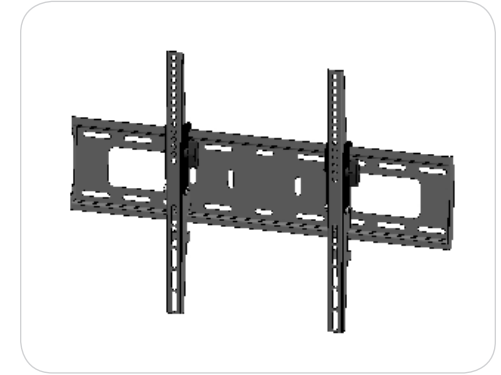

EXT-LG-MB

**Vesa Pattern: 200 x 200
up to 600 x 400mm**

Max weight varies per application

Assembled unit:

25.9" w x 16.7" h x 1.6" d
658mm (w) x 425mm (h) x 40mm (d)

Shipping dimensions:

28" l x 6" h x 6" d
711mm (l) x 152mm (h) x 152mm (d)

Approximate total shipping weight:

9 lbs / 5 kg

Recommended monitor sizes:

37" - 70"

Included hardware:

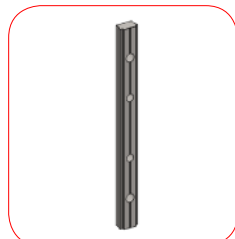

LN-100

x2



M5 x 10

LN-LCD-SCW

x2



1/4"-20 x 1"

BOLT-1

x2



1/4"-20

Flange Wing nut

x2

Extrusion Connection

Channel Connection A

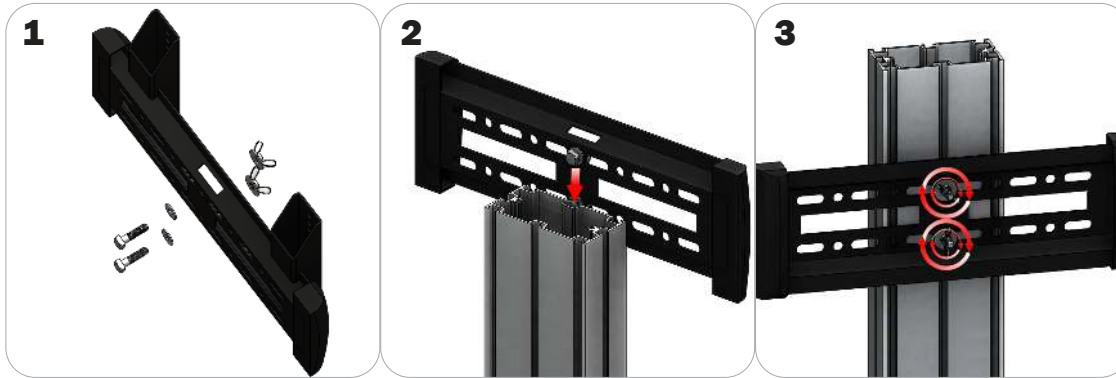

Locate all components needed to assemble the monitor mount with the channel connection A method. You will need (1) monitor bracket, (2) square head bolts, (2) washers, and (2) wing nuts.

Step 1: Insert the provided bolts through the washers and center top and bottom holes of the monitor mount. Loosely thread your wing nuts onto the end of the bolts.

Step 2: Slide the bolt heads down the extrusion channel.

Step 3: Tighten your wing nuts to lock the monitor bracket in place.

Step 4: Reference the included manufacturer monitor mount instructions for fastening your monitor to the bracket.

Channel Connection B

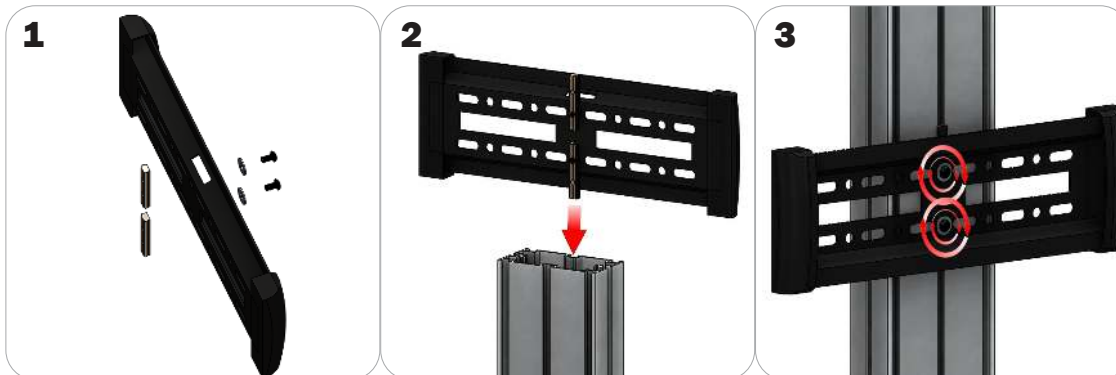

Locate all components needed to assemble the monitor mount with the channel connection B method. You will need (1) monitor bracket, (2) LN-LCD-SCW, (2) LN-100, and (2) washers.

Step 1: Loosely thread the LN-LCD-SCW screws through the washers, the center top and bottom holes of the monitor bracket, and through the LN-50 holes.

Step 2: Slide the LN-100s down the extrusion channel.

Step 3: Tighten your LN-LCD-SCW to lock the monitor bracket in place.

Step 4: Reference the included manufacturer monitor mount instructions for fastening your monitor to the bracket.

Extrusion Connection

TRI-30MM Channel Tube Connection

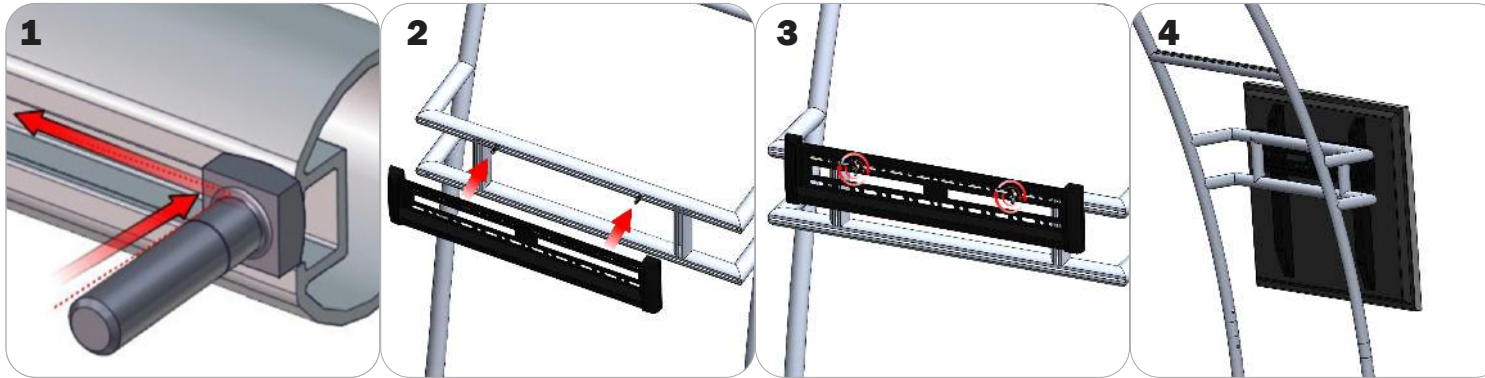

Locate all components needed to assemble the monitor mount with the TRI-30MM Channel Tube Connection method. You will need (1) monitor bracket, (2) Square Bolts, and (2) Wingnuts.

Step 1: Slip the head of the square bolts into the extrusion channel of the tube.

Step 2: Apply your monitor bracket to the protruding square bolts.

Step 3: Lock your monitor bracket to the square bolts using the provided wingnuts.

Step 4: Reference the included manufacturer monitor mount instructions for fastening your monitor to the bracket.

Vector Frame Counter 04

VFC-04

Vector Frame™ counters compliment the Vector Frame series of exhibit kits, but are also ideal for any stand-alone event or display. Vector Frame counters couple simple extrusion-based frames with push-fit graphics. Countertops are available in four colored finishes. Custom sizes also available.







We are continually improving and modifying our product range and reserve the right to vary the specifications without prior notice. All dimensions and weights quoted are approximate and we accept no responsibility for variance. E&OE. See Graphic Templates for graphic bleed specifications.

7/23/2018

features and benefits:

- Feature push-fit fabric graphics and simple extrusion based frames
- Choose from four countertop finishes
- Easy step-by-step instructions
- Wheeled portable shipping case
- Lifetime limited warranty against manufacturer defects

dimensions:

Hardware	Graphic
<p>Assembled unit: 31" w x 40.5" h x 19" d 1400mm(w) x 1029mm(h) x 572mm(d)</p> <p>Approximate unit weight: 52 lbs / 24 kg</p>	<p>Refer to related graphic template for more information</p> <p>Visit: https://www.theexhibitorshandbook.com/download-graphic-templates</p>
Shipping	
<p>Packing case(s) 1 OCH2</p> <p>Shipping dimensions: 52" l x 29" h x 15" d 1321mm(l) x 737mm(h) x 381mm(d)</p> <p>Approximate shipping weight: 82 lbs / 37 kg</p>	
additional information:	
<p>Graphic material: Dye-sublimation SEG push-fit fabric</p> <p>Counter holds max weight 100 lbs / 46 kg</p>	
<p>Tabletop Colors:</p> <div style="display: flex; justify-content: space-around; align-items: center;"> <div style="text-align: center;">  silver </div> <div style="text-align: center;">  black </div> <div style="text-align: center;">  mahogany </div> <div style="text-align: center;">  natural </div> </div>	

Included In Your Kit

Tools, Components, & Connectors



5MM ALLEN-T x1



CB10-R x8

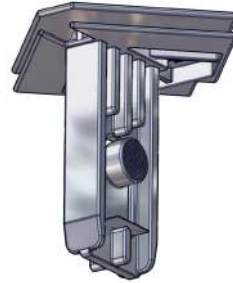

PMFC2-90-CAP x4

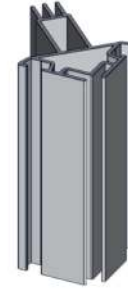

PMFC2-90-986-L1-L1 x2

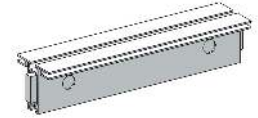

PHFC2-600-L-L x2

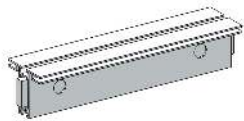

PHFC2-300-L-L x4



TUBE-30-910 x4

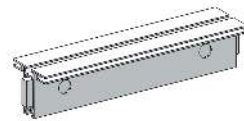

PHFC2-100-L-L x4



VFC-04-CT-S x1



VFC-04-CT x1



PE-1000 x2

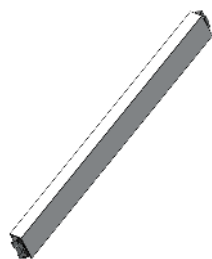

PH1-288-L-L x4

Graphics

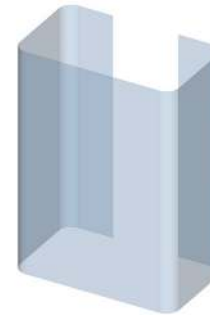

VFC-04-A-G x1



VFC-04-B-G x1

Exploded View

VFC-04
Section 1

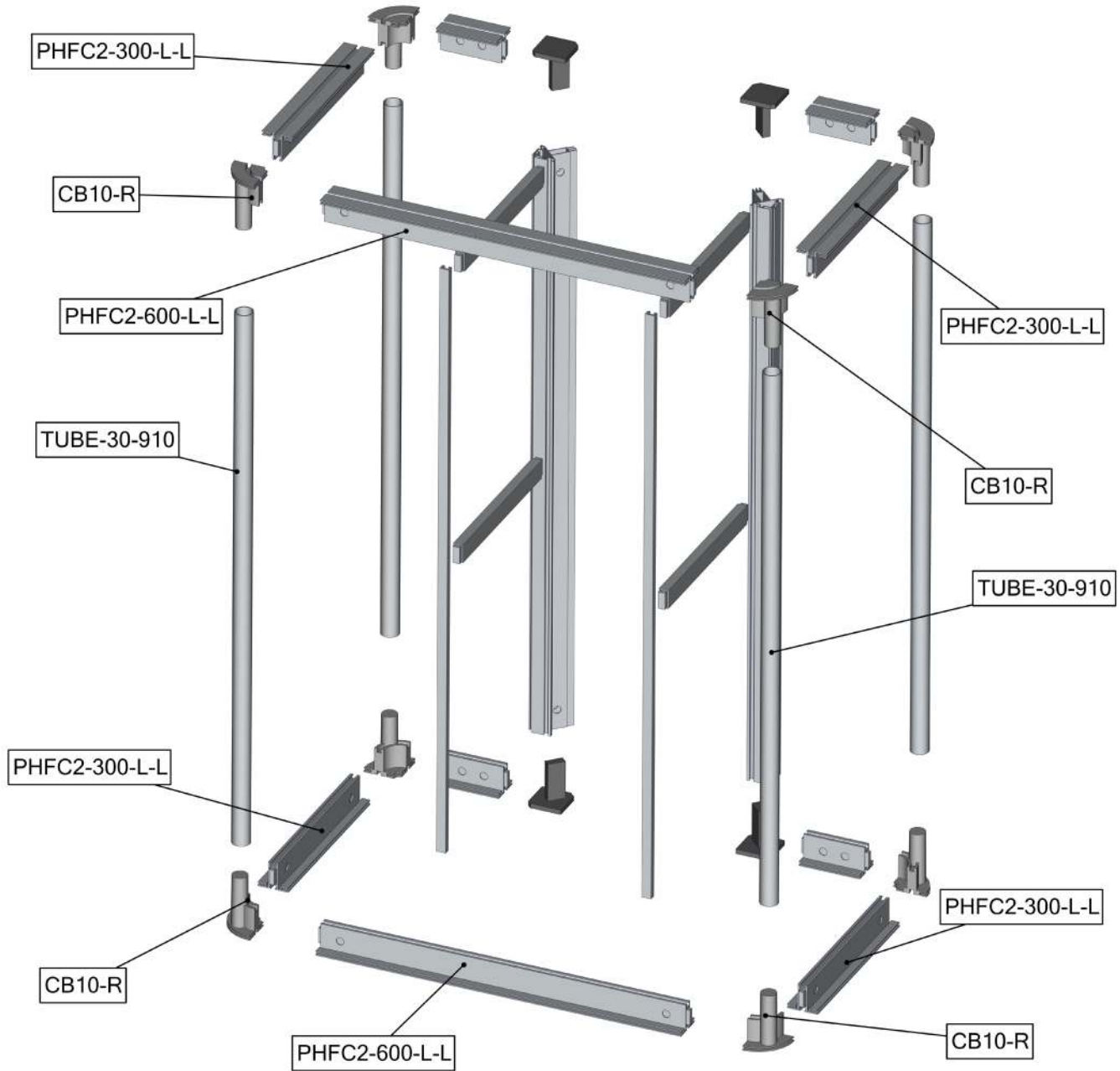

Exploded View

VFC-04
Section 2

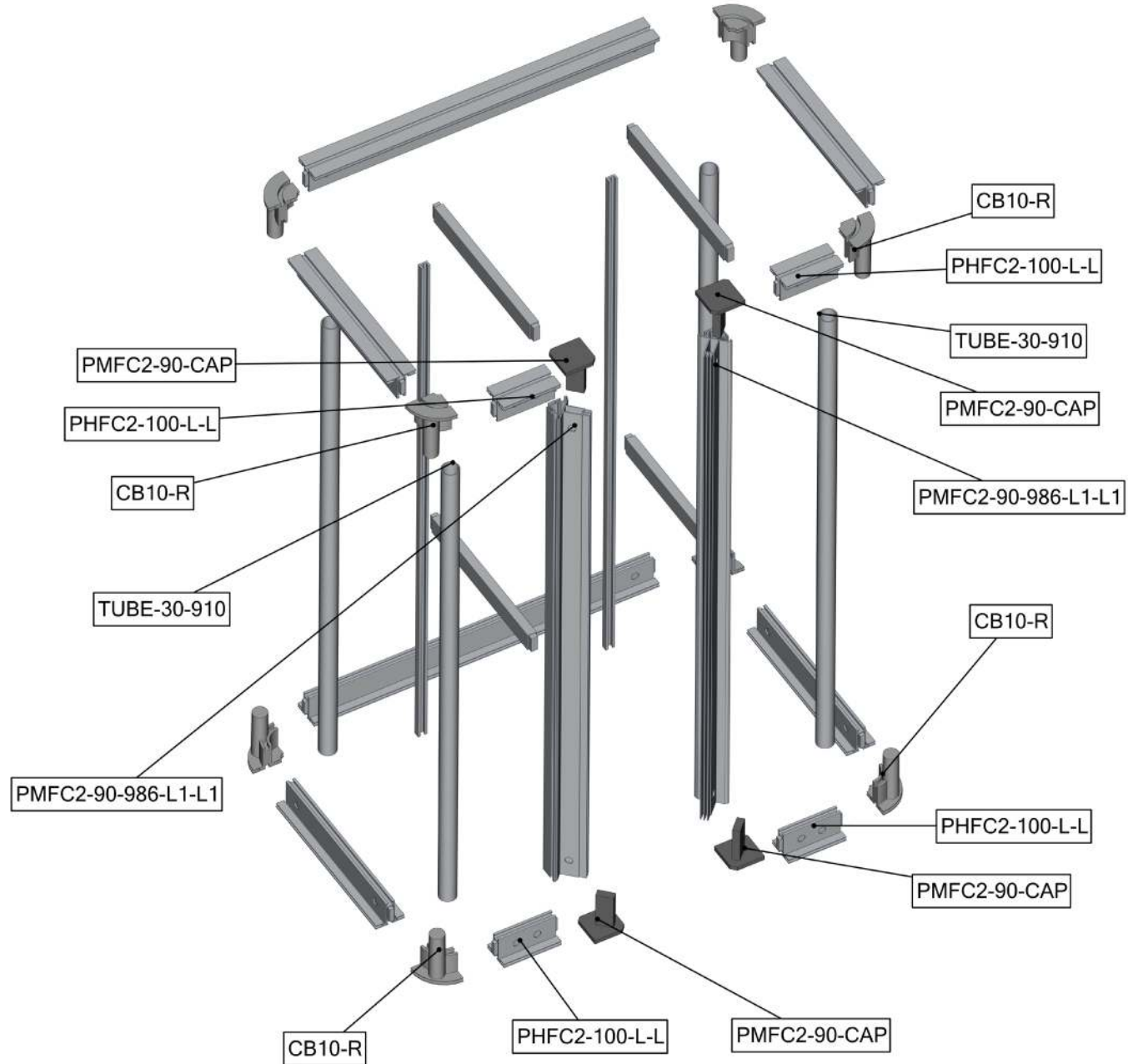

Kit Assembly

Step by Step

Step 1.

Gather the components to build the counter frame sections 1 and 2. Use the Exploded View section 1 and 2 for part labels.

Reference Connection Method(s) 1, 2 and 3 for more details.



Step 2.

Gather the components to build the counter frame section 3. Use the Exploded View section 3 for part labels. Use section 3 to merge sections 1 and 2.

Reference Connection Method(s) 2, 3 and 4 for more details.



Step 3.

Apply the counter fabric graphics by pressing the edges of the graphic into the extrusion fabric channel.

Reference Connection Method 5 for more details.

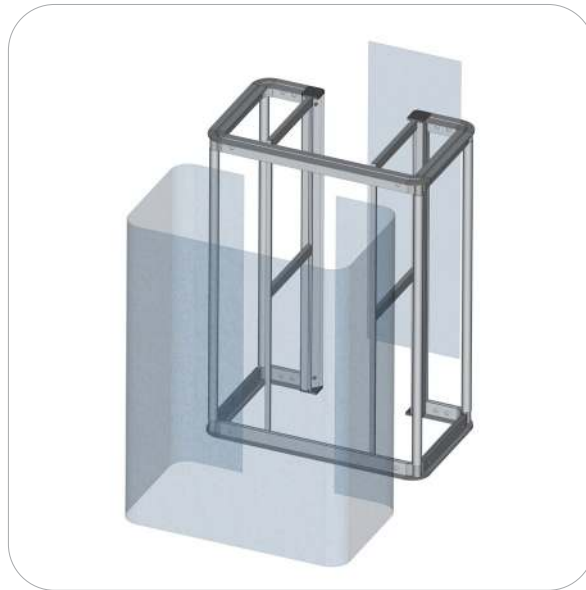

Step 4.

Gather the components to build the counter top and shelf. Use the Exploded View section 3 for part labels.

Reference Connection Method 6 for more details.

Setup is complete.

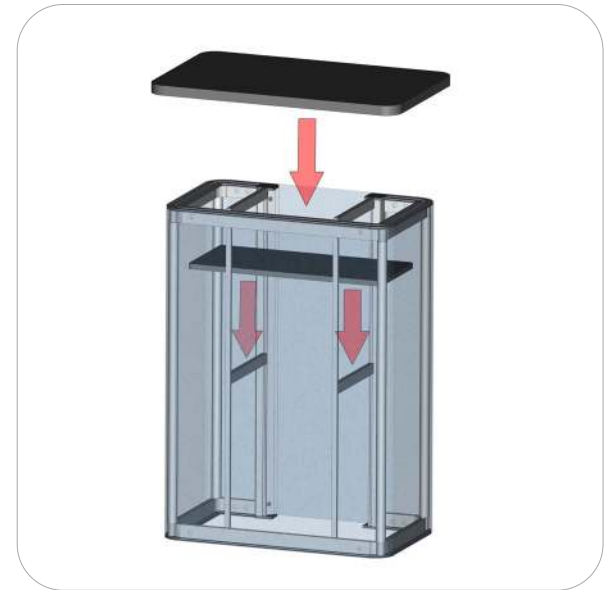

Connection Methods

Connection Method 1: PMFC2-90-CAP



First, press button to insert the cap into the extrusion. The button will snap in place.

Connection Method 2: PMFC2 / PHFC2



First, with the cam lock disengaged, place the cam lock teeth into the extrusion channel. Second, use the allen key tool to lock it in place. Make half turns clock-wise to engage the cam lock. Do not over tighten the lock buttons.

Connection Method 3: CB10-R / PHFC2

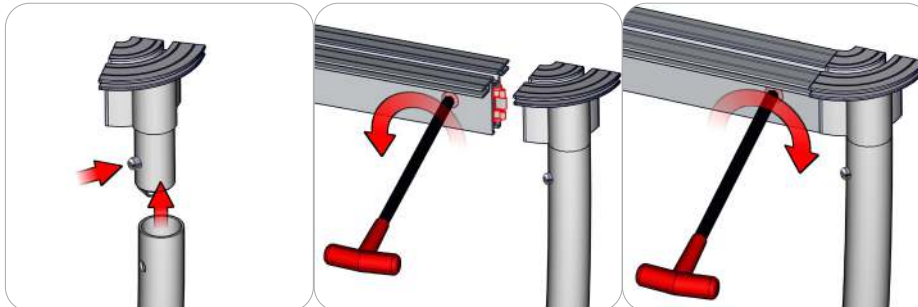

First, press and hold the snap button while you slide it into the tube. The snap button connection is secure when it protrudes through the tube hole. Second, using the allen key tool, disengage the cam lock in the extrusion end and place its teeth into the CB10-R channel. Third, with the cam lock teeth in the channel, use the allen key tool to engage the cam lock. Make a half turn to lock, do not over tighten. Repeat for opposite end.

Connection Method 4: CAM LOCK / PE



First, with the cam lock disengaged, place the cam lock teeth into the extrusion channel. Second, use the allen key tool to lock it in place. Make half turns clock-wise to engage the cam lock. Do not over tighten the lock buttons.

Connection Methods

Connection Method 5: Silicon Edge (SEG)

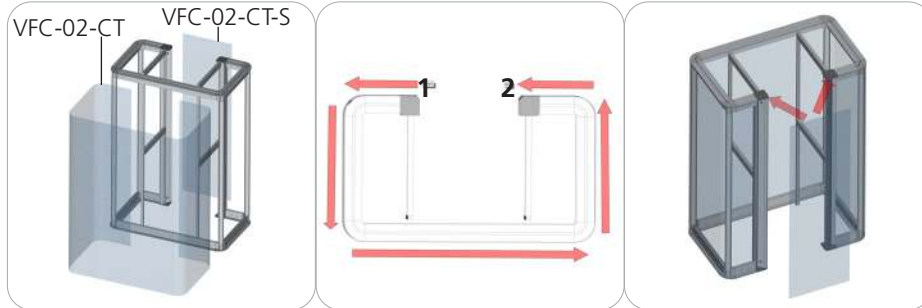

First, at START point 1, start pressing VFC-04-A-G fabric SEG from top to bottom of the counter fabric channels. Second, work the SEG across the rest of the top and bottom counter fabric channels to END point . At END point 2, start pressing the fabric SEG from top to bottom of the counter fabric channel. Third, apply VFC-04-B-G fabric SEG from top to bottom of the counter fabric channels.

Connection Method 6: Counter Top

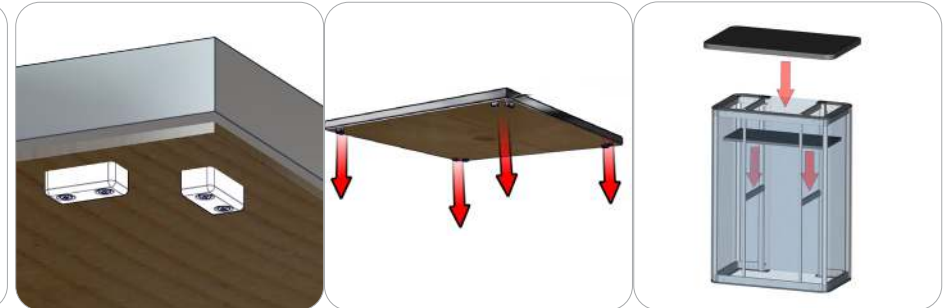

Counter top is held into place by the blocks seen about.