

Hybrid Pro Modular Kit 15

HP-K-15

Hybrid Pro™ Modular exhibits and counters are a perfect solution for the serious exhibitor. Exhibits feature heavy-duty aluminum extrusion frames and push-fit fabric graphics. Count on making an unforgettable impact with Hybrid Pro Modular exhibit kits, counters, and accessories.

features and benefits:

- Silver aluminum extrusion frame
- Single-sided SEG dye-sublimated push-fit fabric graphics
- Pillowcase fabric graphic
- Easy step-by-step instructions
- Kit includes frame, side/top white accent, seven fabric graphic panels, three pillowcase fabric graphics, one backwall counter, one medium monitor mount, one molded OCE case and one SCRATE case
- Lifetime hardware warranty against manufacturer defects

dimensions:

Hardware

Assembled unit:
233.38" w x 95.63" h x 78.75" d
5928mm(w) x 2429mm(h) x 2000mm(d)

Counter:
30.63" w x 40.5" h x 18.75" d approx.
778mm(w) x 1029mm(h) x 476mm(d)

Counter holds max weight 50 lbs / 22.68 kgs

Shipping

Shipping dimensions - ships in 2 cases:
1 OCE case: 18" l x 40" - 66" h x 18" d
457mm(l) x 1016mm - 1676mm(h) x 457mm(d)

1 SCRATE case: 59" l x 57" h x 33" d
1499mm(l) x 1448mm(h) x 838mm(d)

Approximate shipping weight (entire kit):
449 lbs / 204 kgs

additional information:

Graphic material: Dye-sublimated fabric

Medium monitor bracket holds 32-55" LCD,
max. weight 50 lbs / 22.68 kgs
*LCD monitor not included

Tabletop Colors:



silver



black



mahogany



natural

Graphic

Refer to related graphic templates for more information

Visit:
www.exhibitors-handbook.com/graphic-templates



We are continually improving and modifying our product range and reserve the right to vary the specifications without prior notice. All dimensions and weights quoted are approximate and we accept no responsibility for variance. E&OE. See Graphic Templates for graphic bleed specifications.

R-HP-K-15

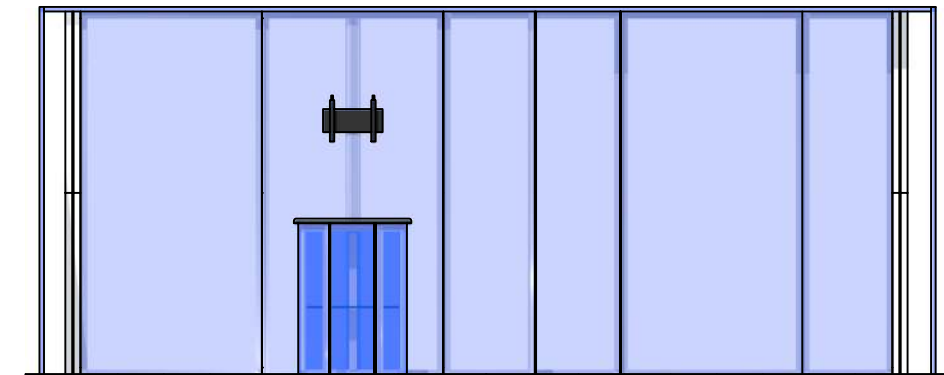
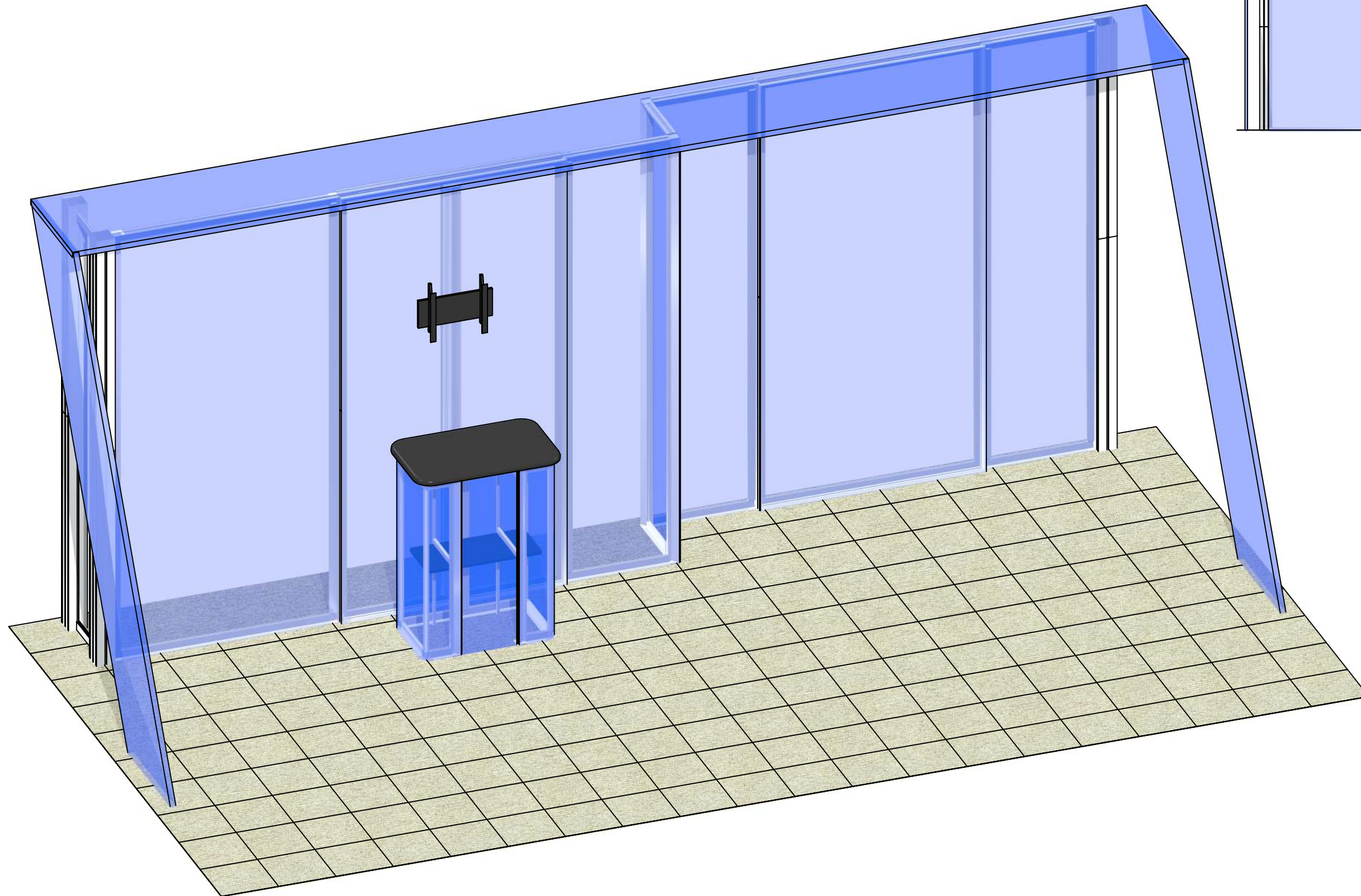

Code	#	Description
R65	4	1193MM (46.97") PMFC2-90 EXTRUSION-WITH IB2 LOCK HOLES BOTH SIDES
R9	2	1200MM (47.24") PHFC4 EXTRUSION WITH MITRE CUT 1 END FOR CB9 ONE END-IB2 HOLES ONE END
R9	2	1200MM (47.24") PHFC4 EXTRUSION WITH MITRE CUT BOTH ENDS
R27	8	1200MM (47.24") PHFC4 EXTRUSION WITH MITRE CUT 1 END FOR CB9 ONE END-IB2 HOLES ONE END
IB2	12	PH INLINE CONNECTOR
CB9	8	CB9 CORNER BRACKET
R55	6	510MM (20.08") PHFC2 EXTRUSION WITH LOCKS 2 ENDS
R19	12	1155MM (45.47") PHFC2 EXTRUSION WITH IB2 HOLE ONE SIDE-WITH LOCK 1 END WITH BIKE LOCKS
R12	2	1155MM (45.47") 100MM PM4R8 ROUND EXTRUSION WITH LOCKS 1 END WITH PH2 STOP AT 305MM
R14	1	300MM (11.81") PM4D CONNECTOR WITH TENSION GLIDES
CB9-S	12	50MM SQUARE PHFC2 CORNER BRACKET
R37	2	1110MM (43.70") PHFC2 EXTRUSION WITH LOCKS 2 ENDS
PMFC2-90-CP	4	PMFC2 90 DEGREE EXTRUSION CAP
R64	2	339MM (13.35") PHFC2 EXTRUSION WITH LOCKS 2 ENDS
R15	6	1200MM (47.24") 100MM PM4S2 SQUARE EXTRUSION WITH PH2 STOP AT 600MM
GRAPHIC G	1	94.5"H X 23.62"W SINGLE SIDED DYESUB GRAPHIC W/FCE-2 ON PERIMETER
R13	3	600MM (23.62") PM4D CONNECTOR WITH TENSION GLIDES
GRAPHIC C	1	94.5"H X 23.82"W SINGLE SIDED DYESUB GRAPHIC W/FCE-2 ON PERIMETER
R8	2	300MM (11.81") PH EXTRUSION WITH LOCKS 2 ENDS
CUST-FS	1	APPROX. 230" W X 24" D 30MM TUBE STRUCTURE CANOPY
CUST-FS	2	APPROX. 124" L X 20" D ANGLED 30MM TUBE STRUCTURE
CUSTOM FS	1	ONE PIECE CUSTOM 30MM TUBE FABRIC STRUCTURE
GRAPHIC A	1	94.5"H X 47.24"W SINGLE SIDED DYESUB GRAPHIC W/FCE-2 ON PERIMETER
GRAPHIC B	1	94.5"H X 47.24"W SINGLE SIDED DYESUB GRAPHIC W/ FCE-2 (SEG) ON PERIMETER
GRAPHIC F	1	94.5"H X 47.24"W SINGLE SIDED DYESUB GRAPHIC W/ FCE-2 (SEG) ON PERIMETER
GRAPHIC E	1	94.5"H X 23.82"W SINGLE SIDED DYESUB GRAPHIC W/FCE-2 ON PERIMETER
GRAPHIC D	1	94.5"H X 15.55"W SINGLE SIDED DYESUB GRAPHIC W/FCE-2 ON PERIMETER
EXT-M-MB	1	MEDIUM MONITOR BRACKET FOR MONITORS 32"-55"

BOM

R-HP-K-15

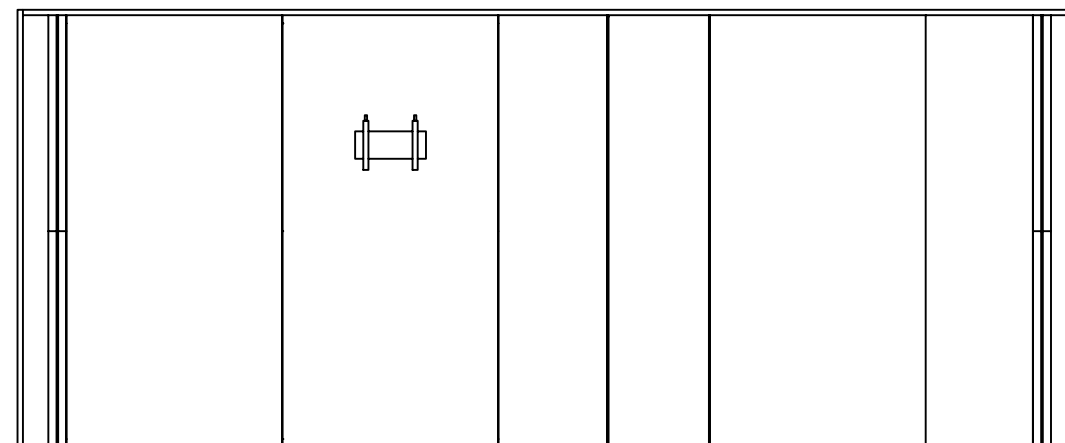
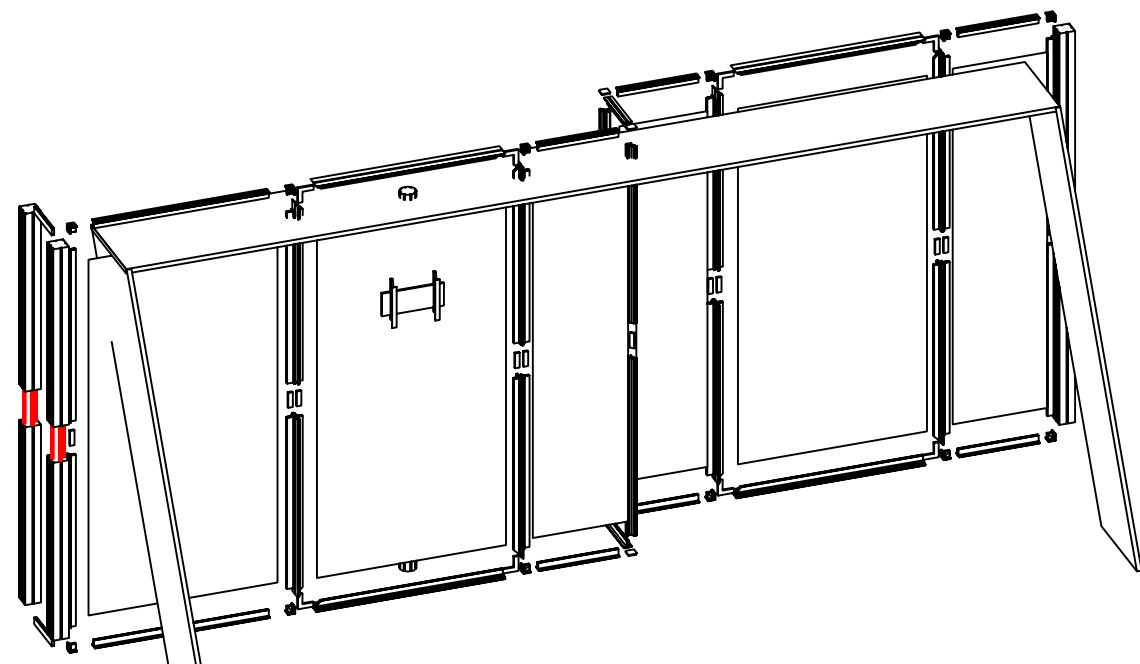
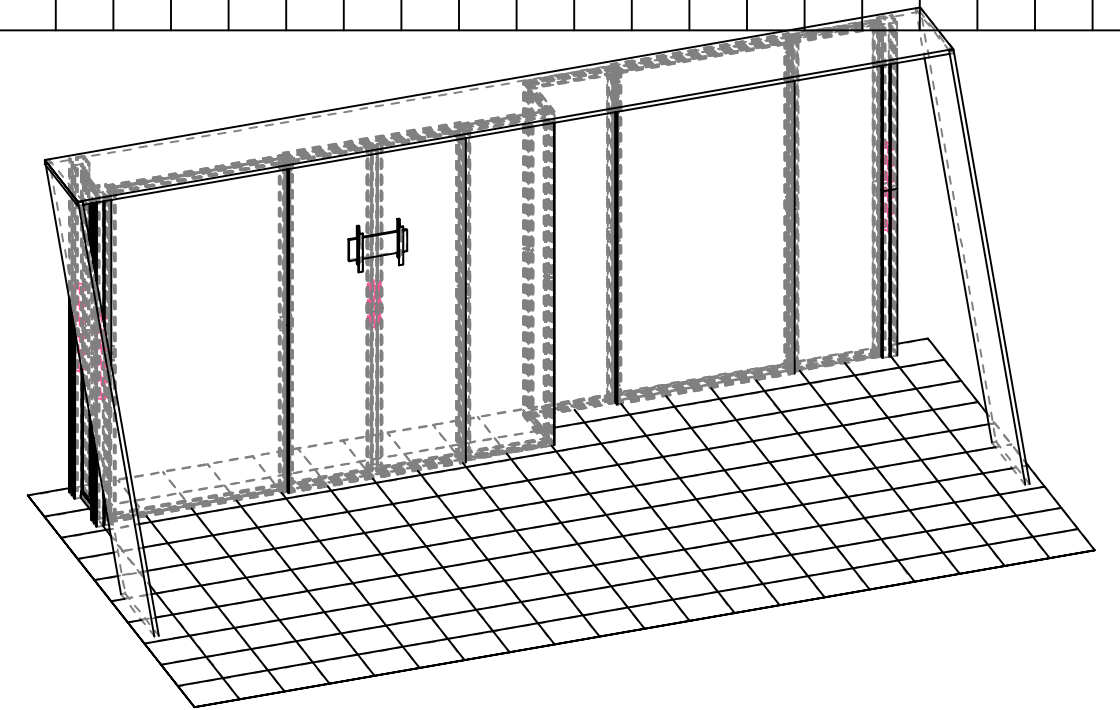
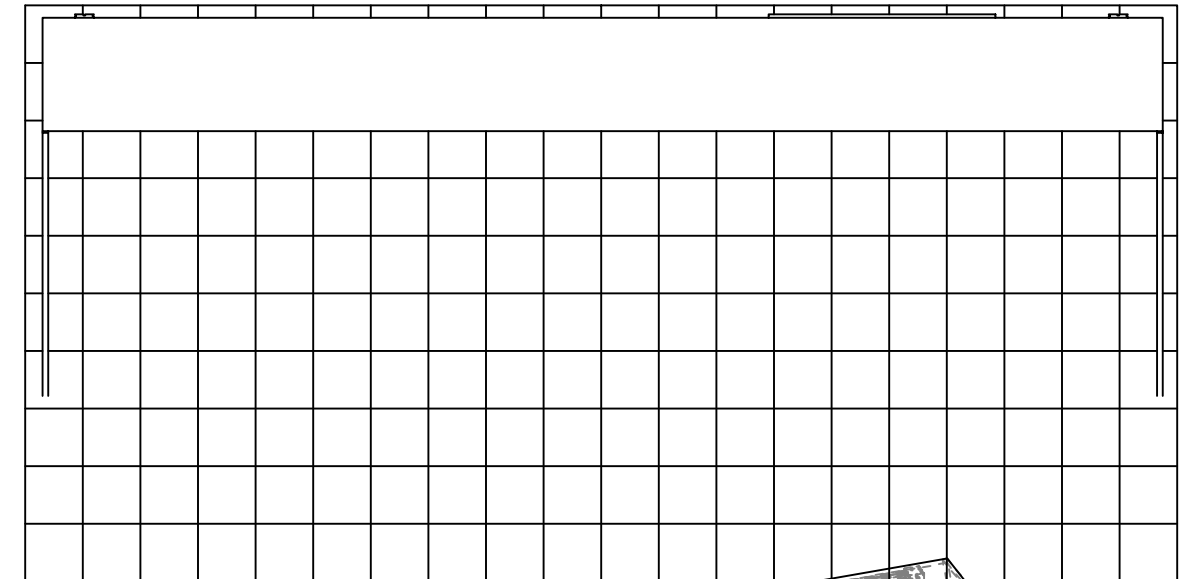

1. Redesign of this exhibit without approval by manufacturer may result in dangerous and unsafe structures. Manufacturer disclaims any responsibility for redesigned exhibits it does not approve in writing.

2. Parts and components such as panels and extrusions are manufactured to metric sizing. Where ever possible sizes have been noted in feet and inches as well as in metric. Below is the imperial to metric sizing table as reference. "Nominal" refers to approximate size.

- | | |
|--------------------|-----------------------------------|
| 2400mm = (94 1/2") | ▼ Phone Line / Fax |
| 2100mm = (82 5/8") | ▼ Internet connection |
| 1800mm = (70 7/8") | ▼ Outlet |
| 1500mm = (59") | ▼ Main Drop (point of distrution) |
| 1200mm = (47 1/4") | |
| 900mm = (35 1/2") | |
| 600mm = (23 5/8") | |
| 300mm = (11 7/8") | |

--- Wire running under carpet

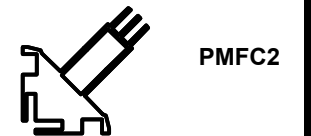
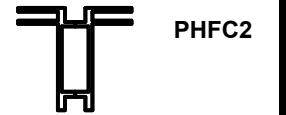
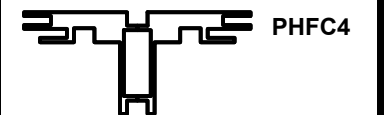
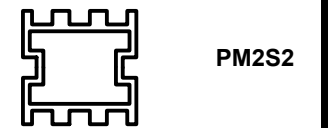
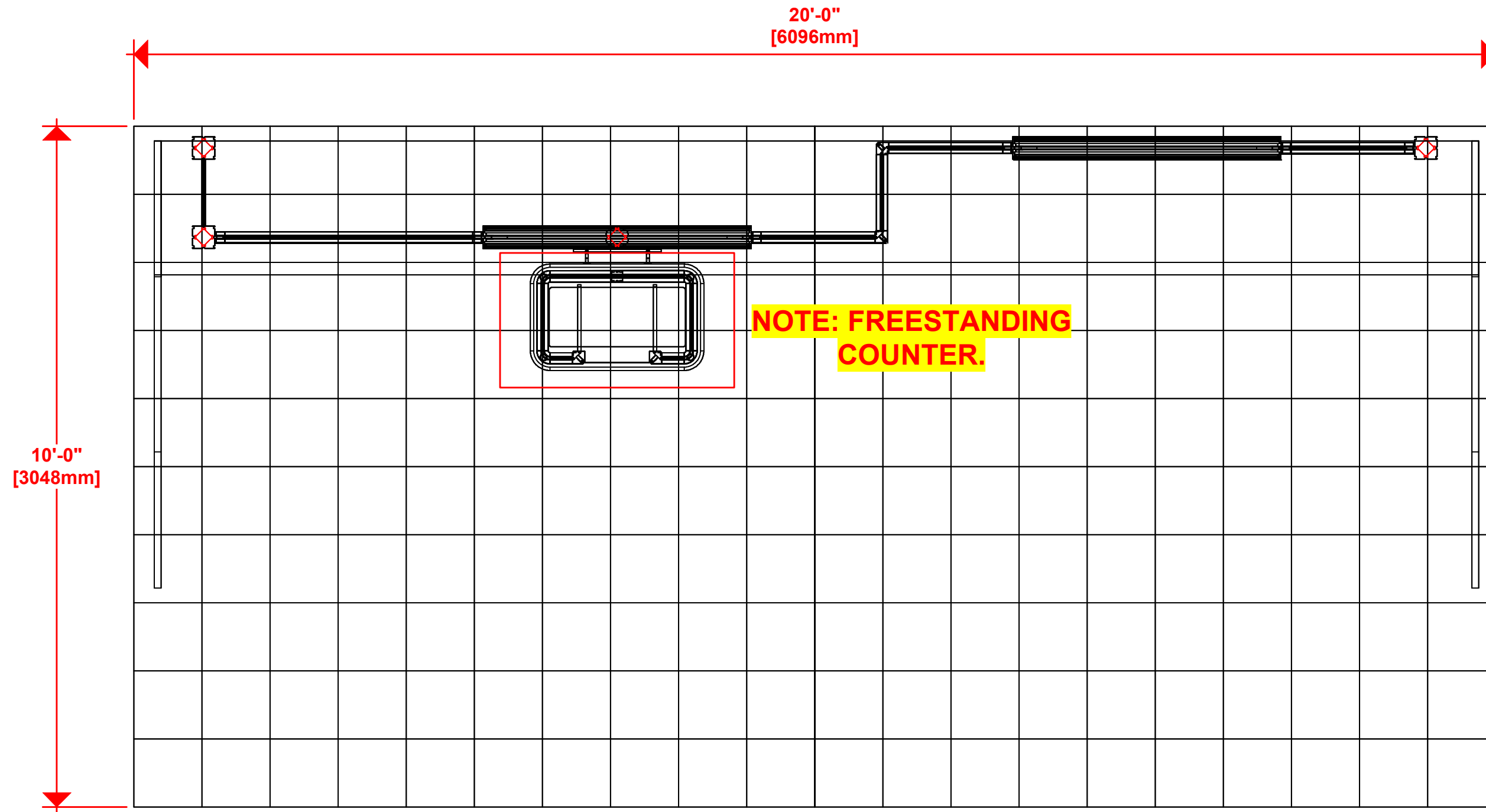

HYBRID PRO RENTAL KIT

Title: SET-UP INSTRUCTIONS

Code	#	Description
R37	2	1110MM (43.70") PHFC2 EXTRUSION WITH LOCKS 2 ENDS
R19	4	1155MM (45.47") PHFC2 EXTRUSION WITH IB2 HOLE ONE SIDE-WITH LOCK 1 END WITH B
IB2	2	PH INLINE CONNECTOR
CB9-S	4	50MM SQUARE PHCF2 CORNER BRACKET

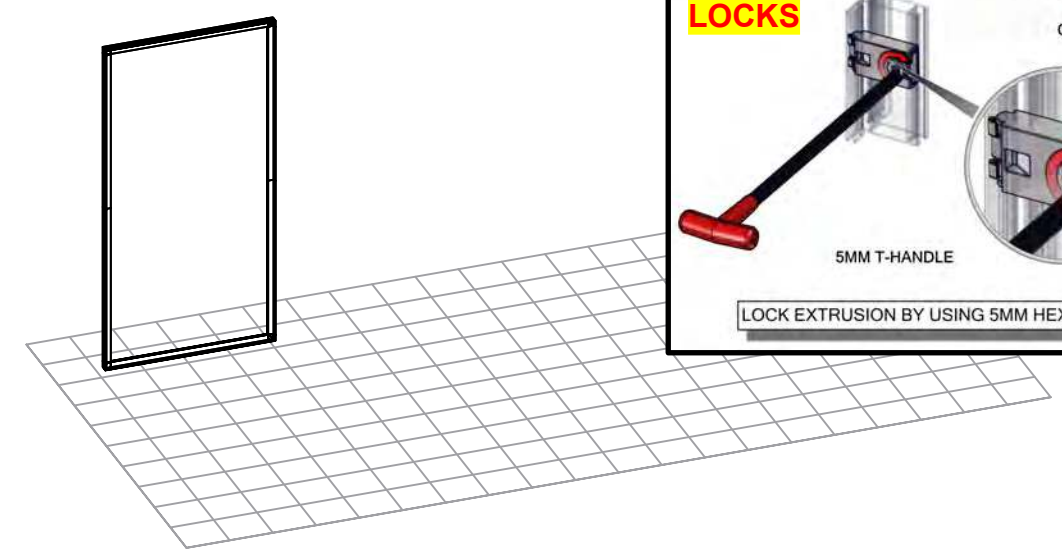
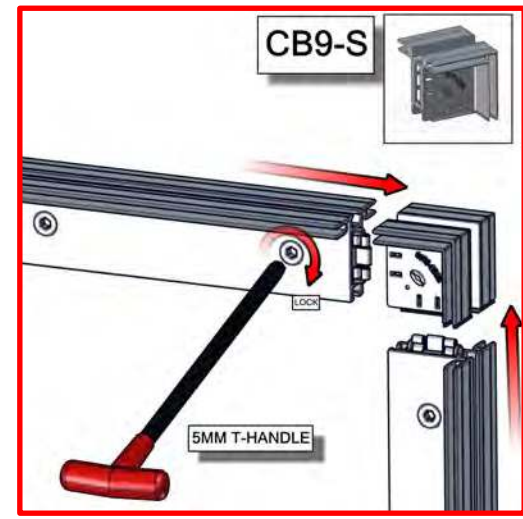
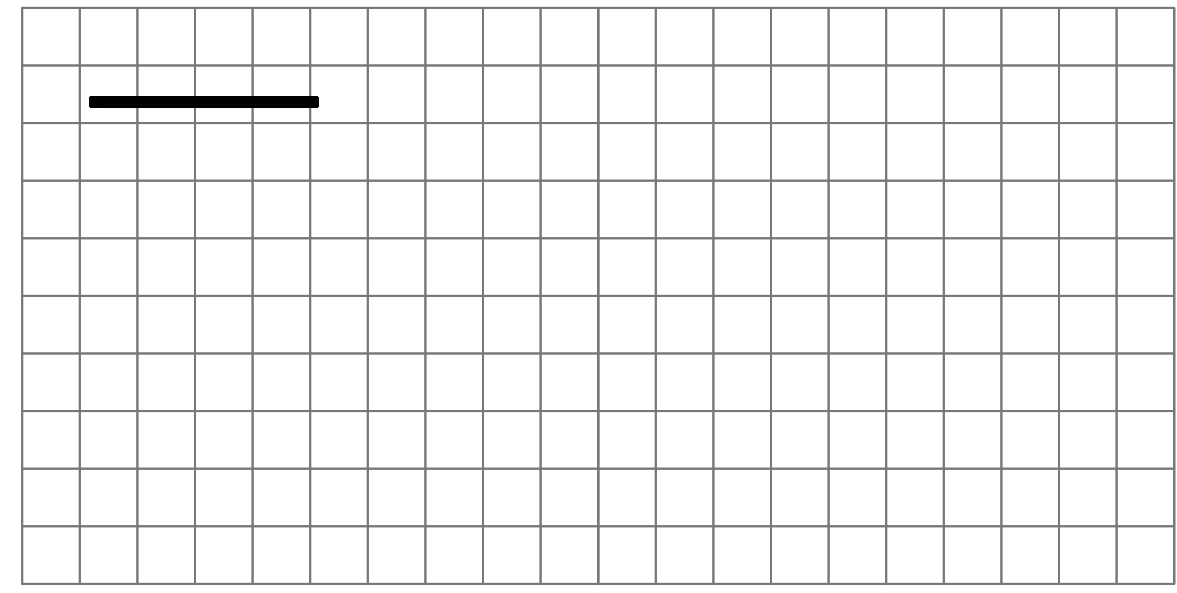
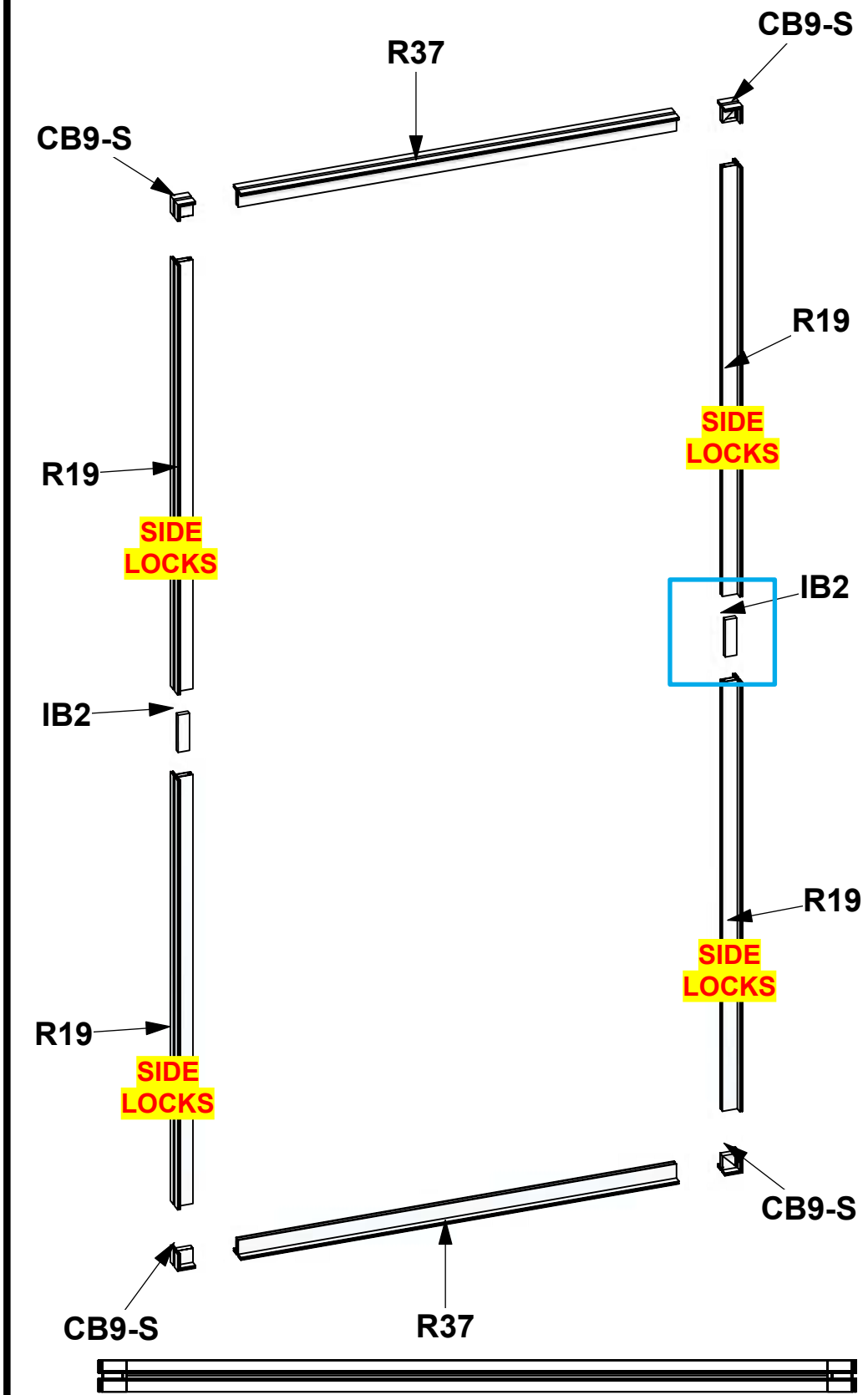

1. Redesign of this exhibit without approval by manufacturer may result in dangerous and unsafe structures. Manufacturer disclaims any responsibility for redesigned exhibits it does not approve in writing.

2. Parts and components such as panels and extrusions are manufactured to metric sizing. Where ever possible sizes have been noted in feet and inches as well as in metric. Below is the imperial to metric sizing table as reference. "Nominal" refers to approximate size.

2400mm = (94 1/2")	Phone Line / Fax
2100mm = (82 5/8")	Internet connection
1800mm = (70 7/8")	Outlet
1500mm = (59")	Main Drop (point of distrution)
1200mm = (47 1/4")	
900mm = (35 1/2")	
600mm = (23 5/8")	
300mm = (11 7/8")	

--- Wire running under carpet

- PM2S2
- PHFC4
- PHFC2
- PH
- PH4SC
- PMFC2

HYBRID PRO RENTAL KIT

Title: SET-UP INSTRUCTIONS

Code	#	Description
R9	1	1200MM (47.24") PHFC4 EXTRUSION WITH MITRE CUT 1 END FOR CB9 ONE END-IB2
R9	1	1200MM (47.24") PHFC4 EXTRUSION WITH MITRE CUT BOTH ENDS
R27	4	1200MM (47.24") PHFC4 EXTRUSION WITH MITRE CUT 1 END FOR CB9 ONE END-IB2
R12	2	1155MM (45.47") 100MM PM4R8 ROUND EXTRUSION WITH LOCKS 1 END WITH PH2 S
R14	1	300MM (11.81") PM4D CONNECTOR WITH TENSION GLIDES
IB2	2	PH INLINE CONNECTOR
CB9	4	CB9 CORNER BRACKET

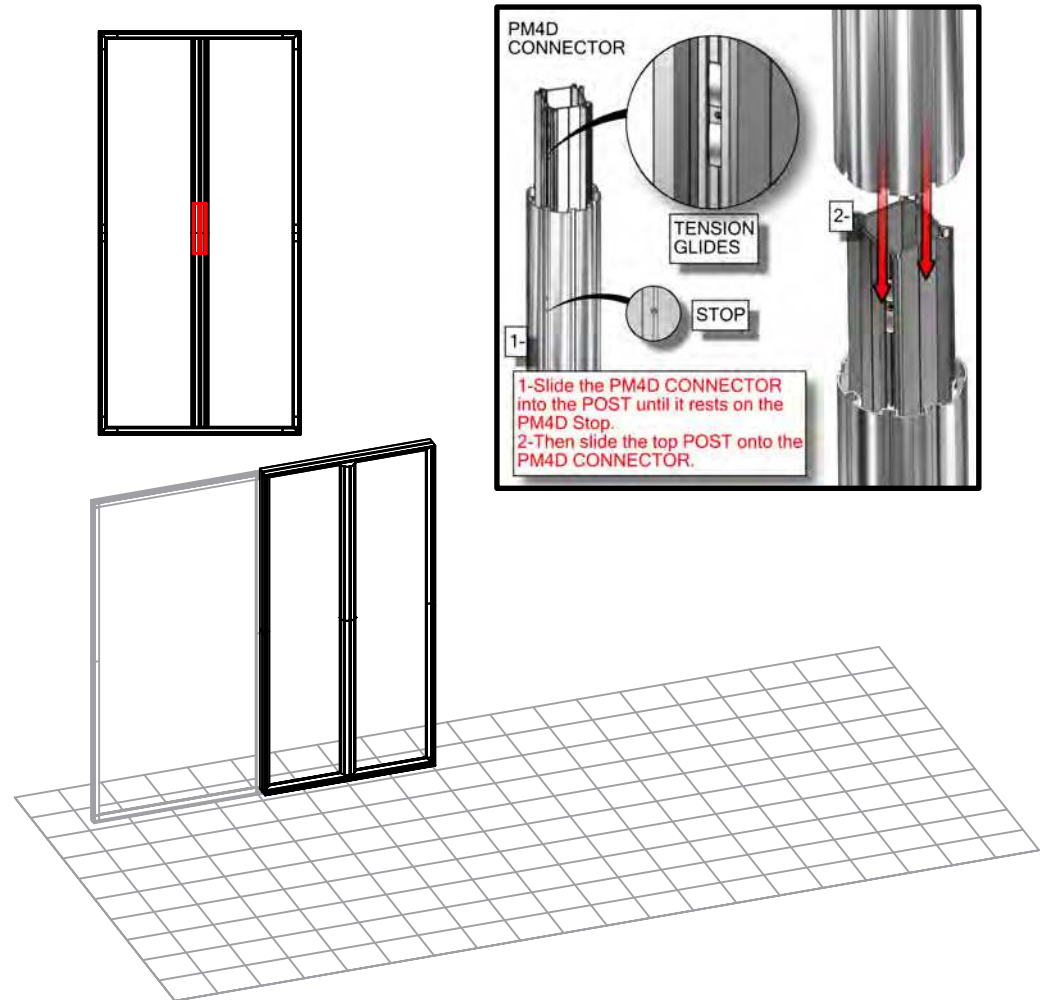
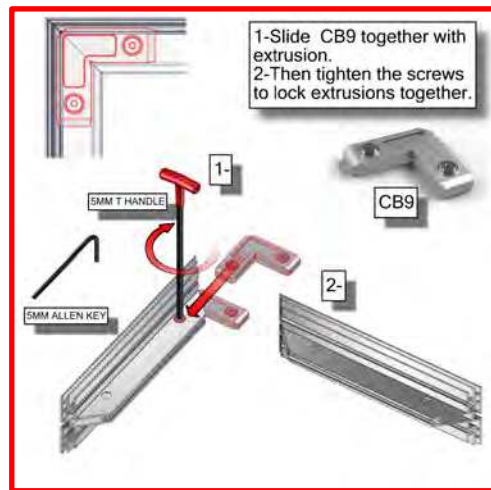

SLIDE SQUARE HEAD BOLTS INTO MIDDLE CHANNEL

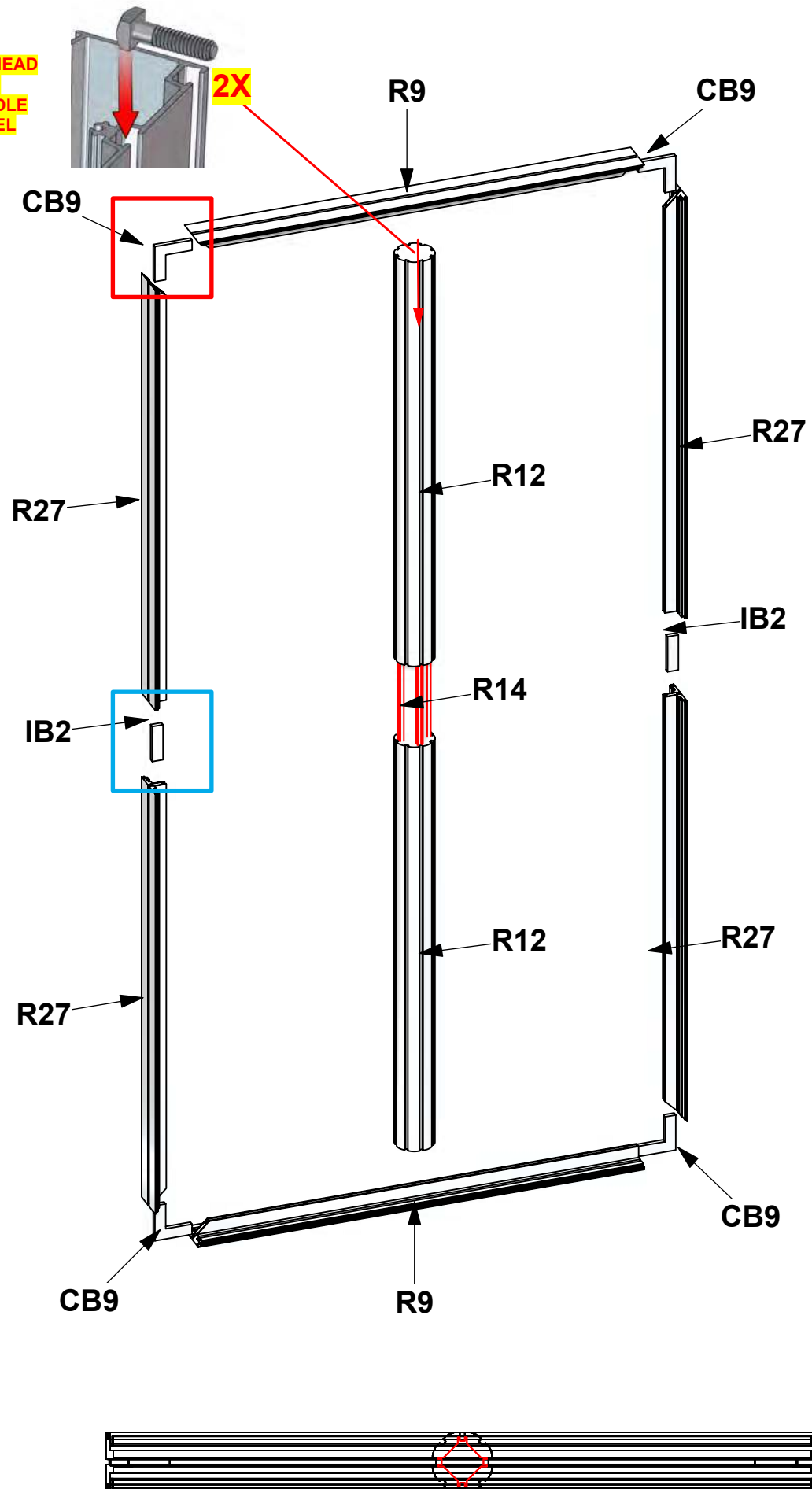

1. Redesign of this exhibit without approval by manufacturer may result in dangerous and unsafe structures. Manufacturer disclaims any responsibility for redesigned exhibits it does not approve in writing.

2. Parts and components such as panels and extrusions are manufactured to metric sizing. Where ever possible sizes have been noted in feet and inches as well as in metric. Below is the imperial to metric sizing table as reference. "Nominal" refers to approximate size.

2400mm = (94 1/2")	Phone Line / Fax
2100mm = (82 5/8")	Internet connection
1800mm = (70 7/8")	Outlet
1500mm = (59")	Main Drop (point of distrution)
1200mm = (47 1/4")	
900mm = (35 1/2")	
600mm = (23 5/8")	
300mm = (11 7/8")	

--- Wire running under carpet

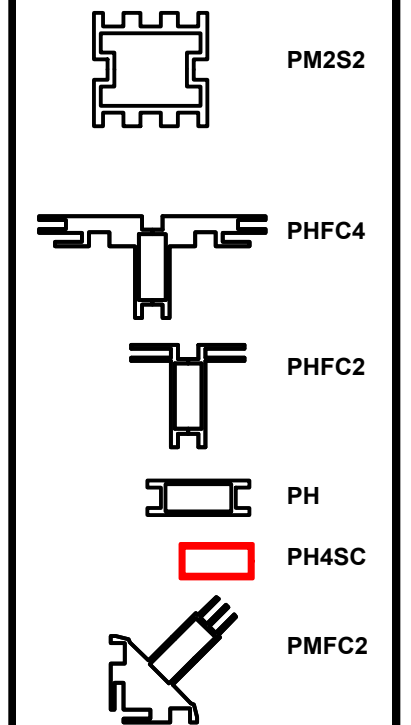

HYBRID PRO RENTAL KIT

Title: SET-UP INSTRUCTIONS

Code	#	Description
R65	2	1193MM (46.97") PMFC2-90 EXTRUSION-WITH IB2 LOCK HOLES BOTH SIDES
IB2	2	PH INLINE CONNECTOR
R55	2	510MM (20.08") PHFC2 EXTRUSION WITH LOCKS 2 ENDS
R19	2	1155MM (45.47") PHFC2 EXTRUSION WITH IB2 HOLE ONE SIDE-WITH LOCK 1 E
CB9-S	2	50MM SQUARE PHCF2 CORNER BRACKET
PMFC2-90-CP	2	PMFC2 90 DEGREE EXTRUSION CAP

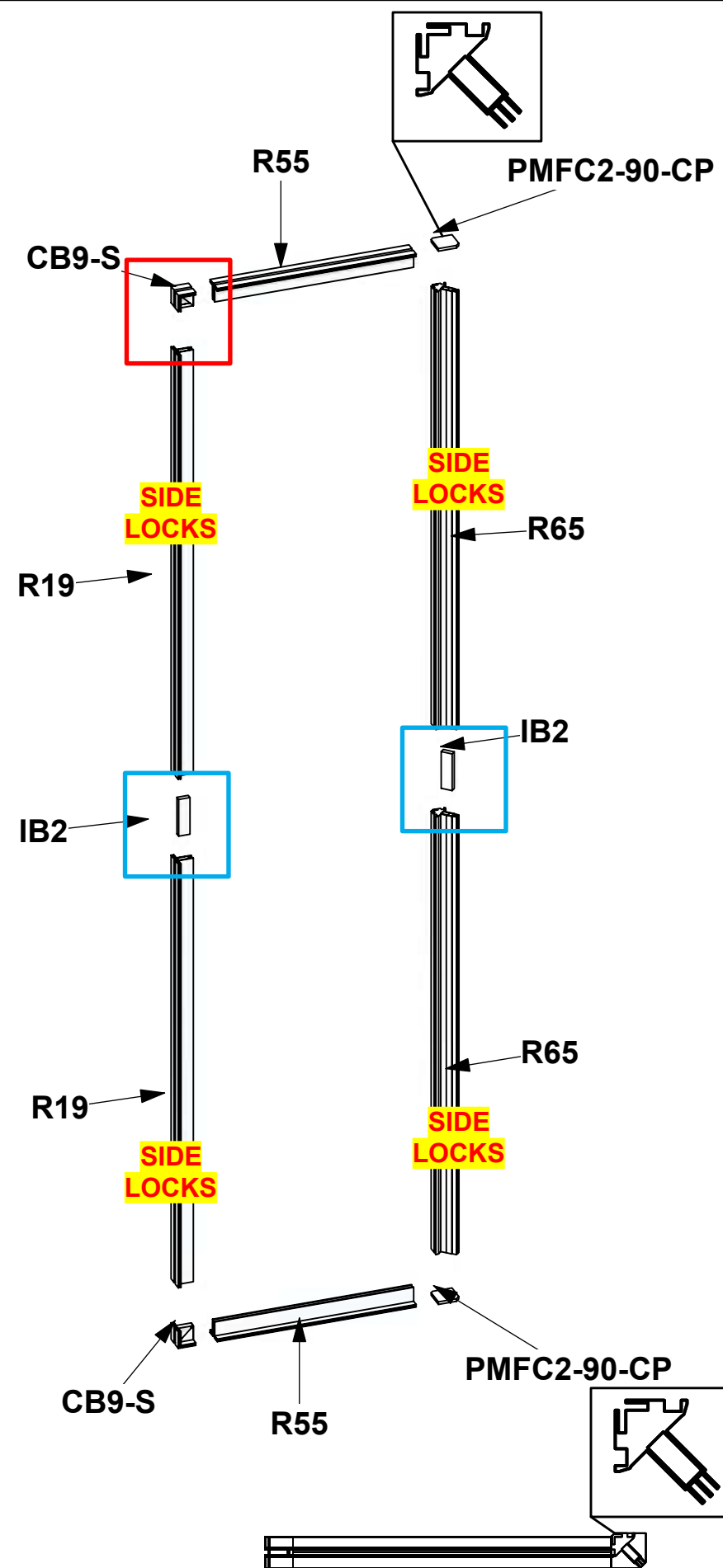
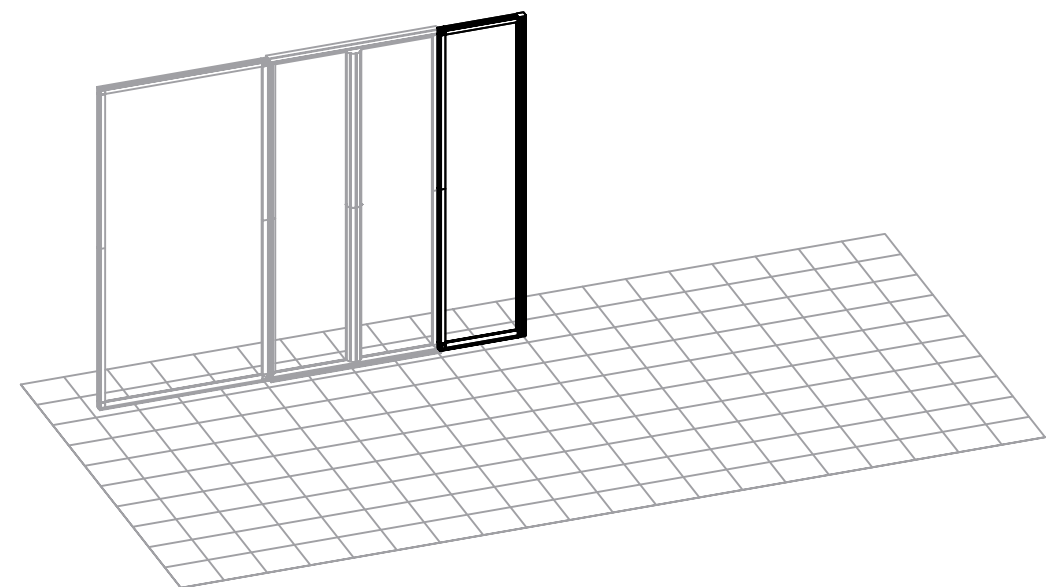
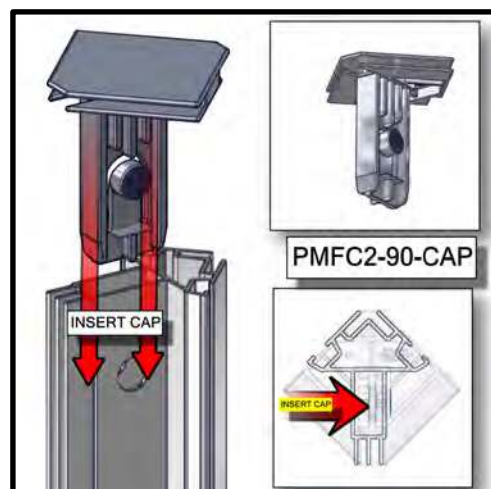
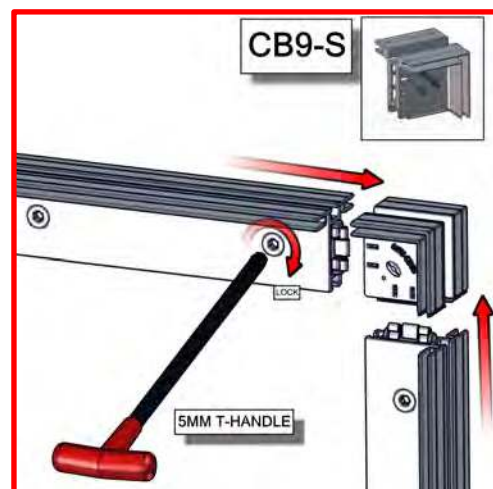

1. Redesign of this exhibit without approval by manufacturer may result in dangerous and unsafe structures. Manufacturer disclaims any responsibility for redesigned exhibits it does not approve in writing.

2. Parts and components such as panels and extrusions are manufactured to metric sizing. Where ever possible sizes have been noted in feet and inches as well as in metric. Below is the imperial to metric sizing table as reference. "Nominal" refers to approximate size.

2400mm = (94 1/2")	Phone Line / Fax
2100mm = (82 5/8")	Internet connection
1800mm = (70 7/8")	Outlet
1500mm = (59")	Main Drop (point of distrution)
1200mm = (47 1/4")	
900mm = (35 1/2")	
600mm = (23 5/8")	
300mm = (11 7/8")	

--- Wire running under carpet

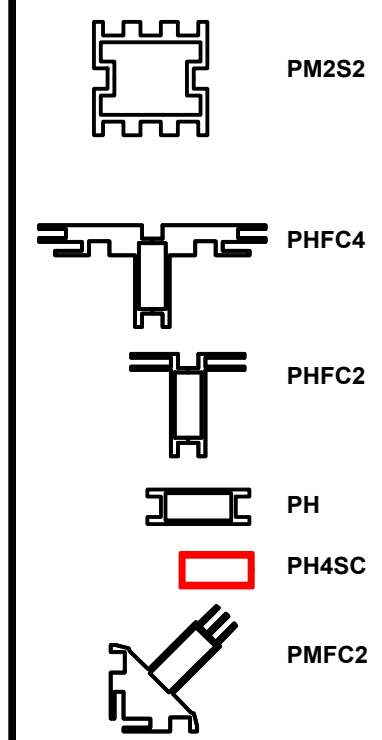

HYBRID PRO RENTAL KIT

Title: SET-UP INSTRUCTIONS

Code	#	Description
R55	2	510MM (20.08") PHFC2 EXTRUSION WITH LOCKS 2 ENDS
R19	2	1155MM (45.47") PHFC2 EXTRUSION WITH IB2 HOLE ONE SIDE-WITH LOCK 1 END W
IB2	2	PH INLINE CONNECTOR
CB9-S	2	50MM SQUARE PHCF2 CORNER BRACKET
R65	2	1193MM (46.97") PMFC2-90 EXTRUSION-WITH IB2 LOCK HOLES BOTH SIDES
PMFC2-90-CP	2	PMFC2 90 DEGREE EXTRUSION CAP

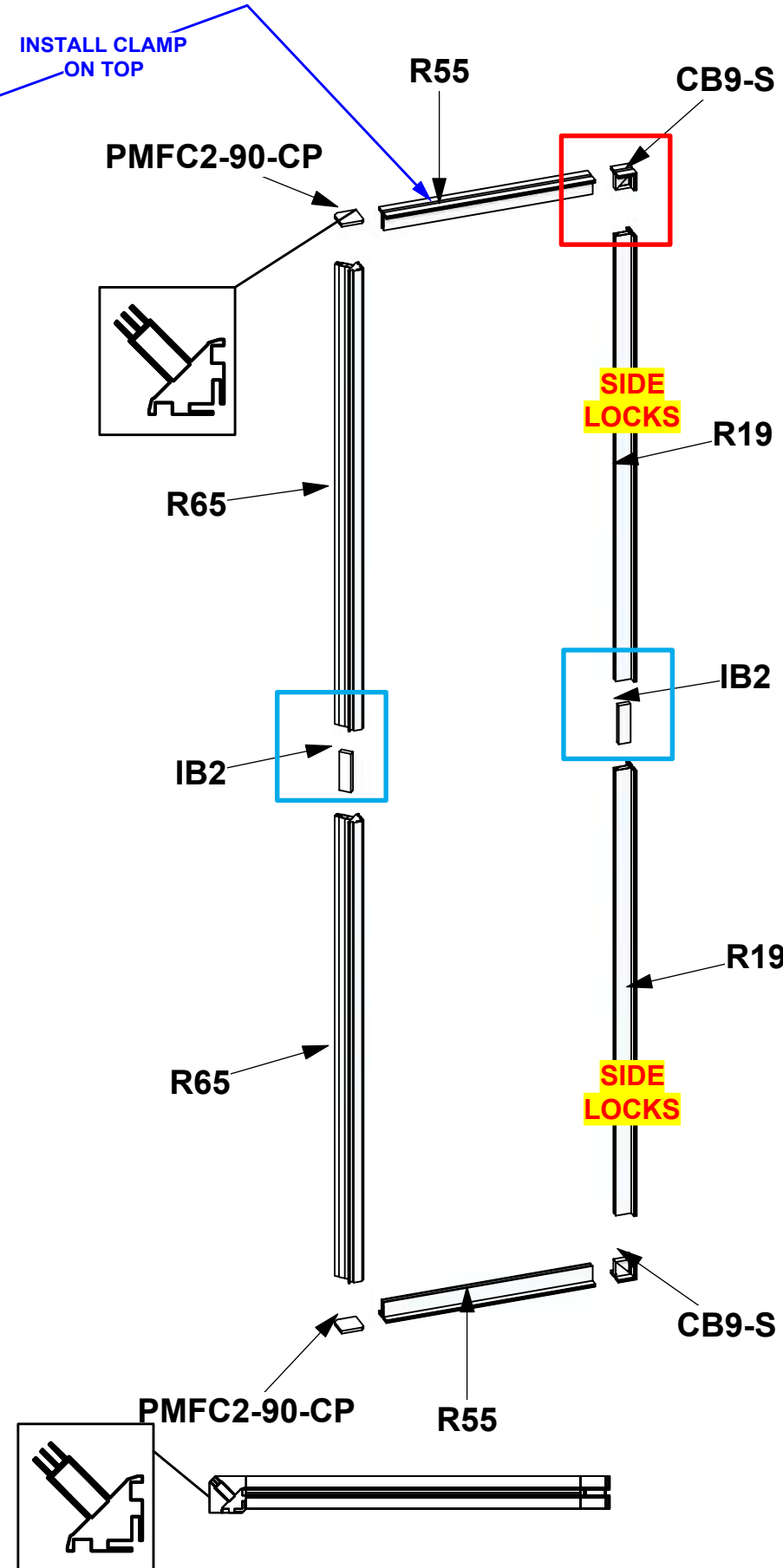
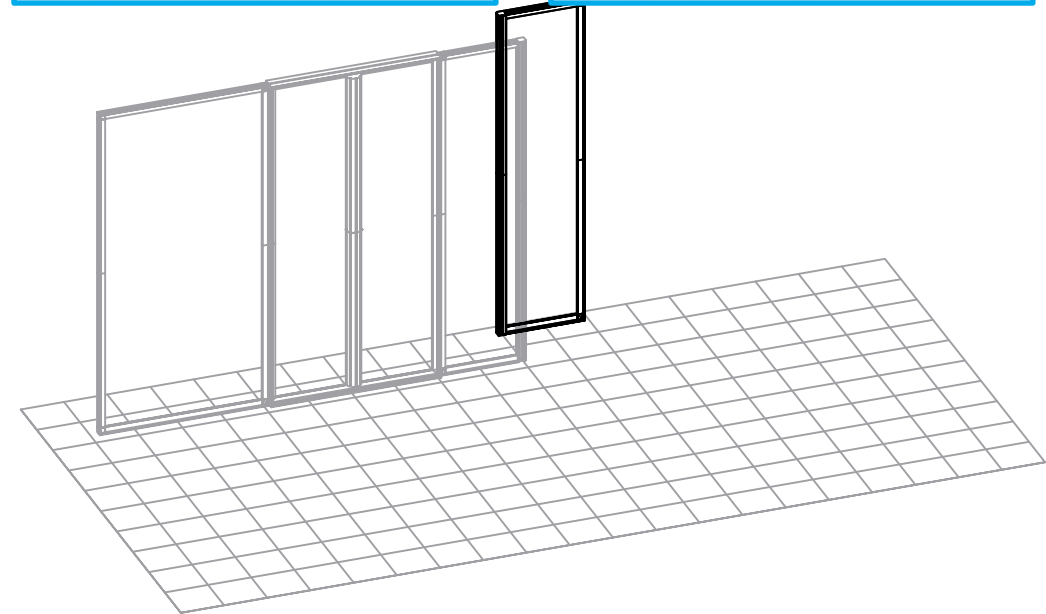
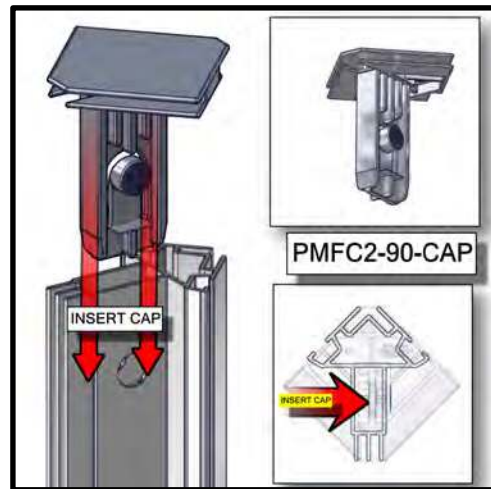
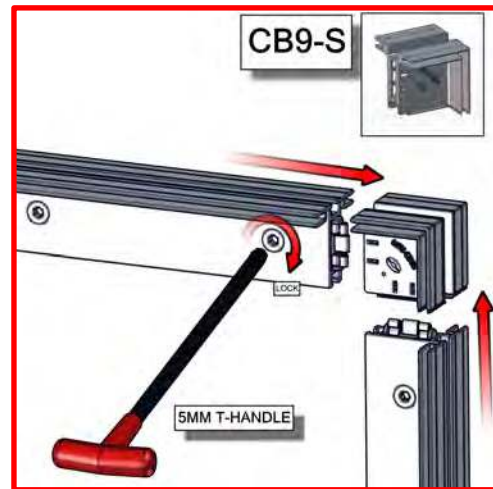

1. Redesign of this exhibit without approval by manufacturer may result in dangerous and unsafe structures. Manufacturer disclaims any responsibility for redesigned exhibits it does not approve in writing.

2. Parts and components such as panels and extrusions are manufactured to metric sizing. Where ever possible sizes have been noted in feet and inches as well as in metric. Below is the imperial to metric sizing table as reference. "Nominal" refers to approximate size.

2400mm = (94 1/2")	Phone Line / Fax
2100mm = (82 5/8")	Internet connection
1800mm = (70 7/8")	Outlet
1500mm = (59")	Main Drop (point of distrution)
1200mm = (47 1/4")	
900mm = (35 1/2")	
600mm = (23 5/8")	
300mm = (11 7/8")	

--- Wire running under carpet

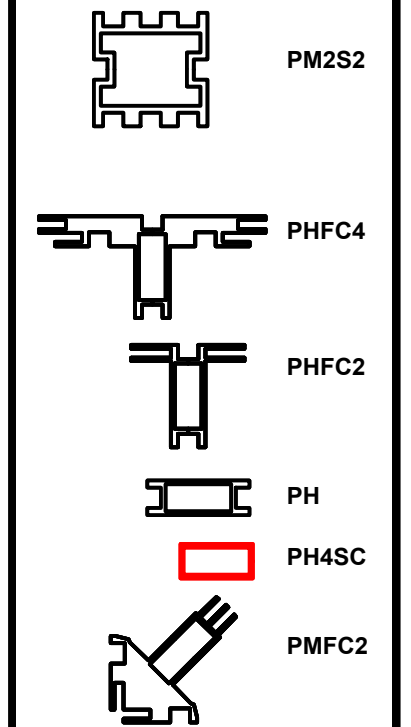

HYBRID PRO RENTAL KIT

Title: SET-UP INSTRUCTIONS

Code	#	Description
R9	1	1200MM (47.24") PHFC4 EXTRUSION WITH MITRE CUT 1 END FOR CB9 ONE END
R9	1	1200MM (47.24") PHFC4 EXTRUSION WITH MITRE CUT BOTH ENDS
R27	4	1200MM (47.24") PHFC4 EXTRUSION WITH MITRE CUT 1 END FOR CB9 ONE END
IB2	2	PH INLINE CONNECTOR
CB9	4	CB9 CORNER BRACKET

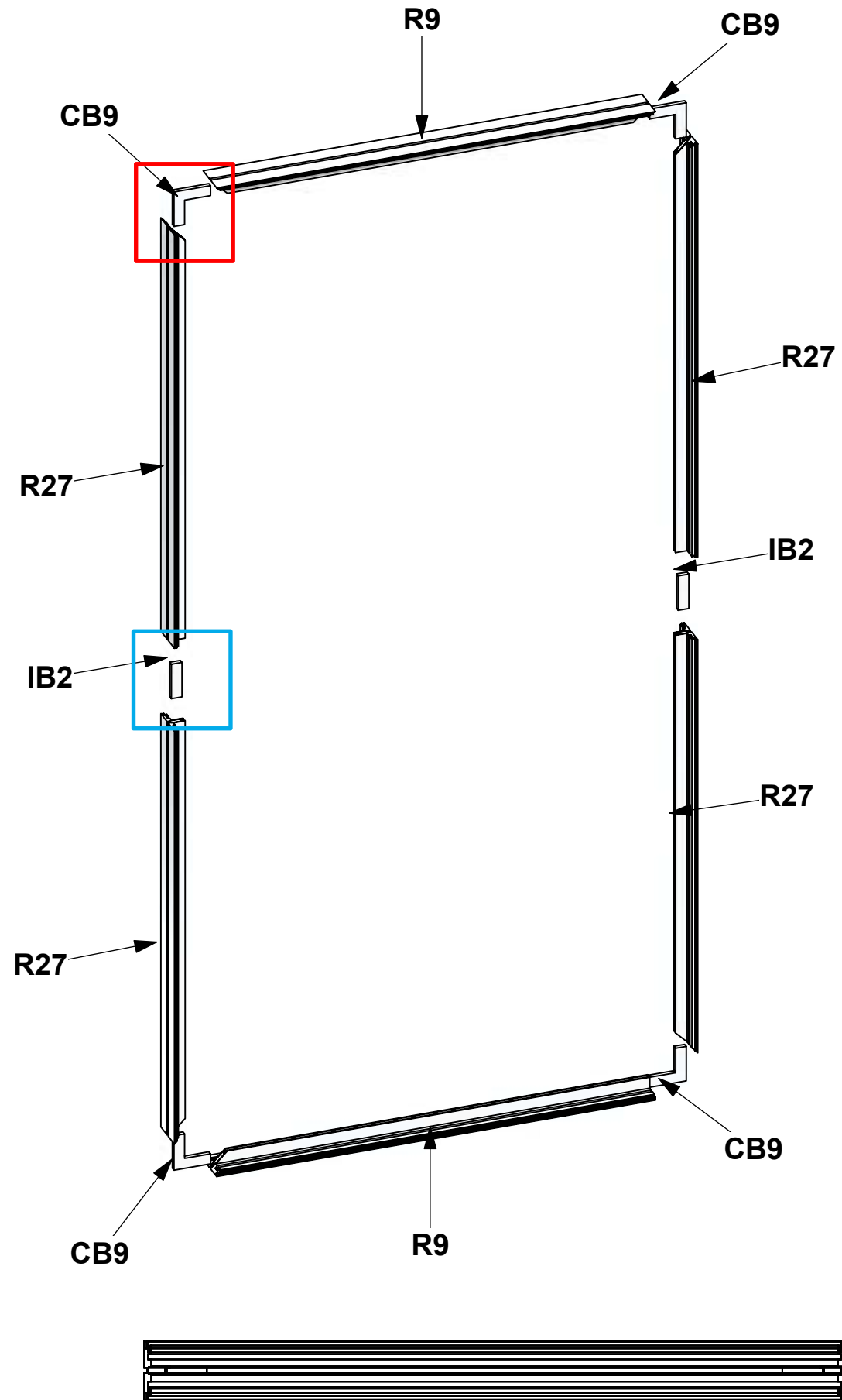
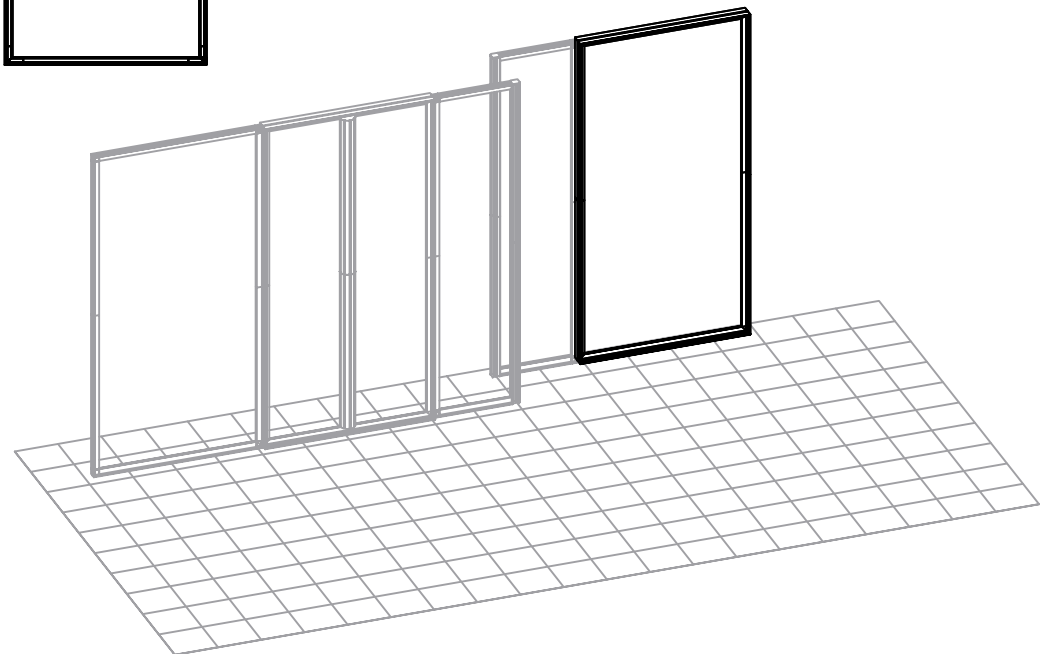
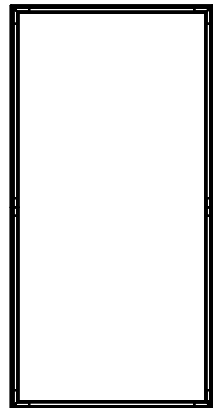
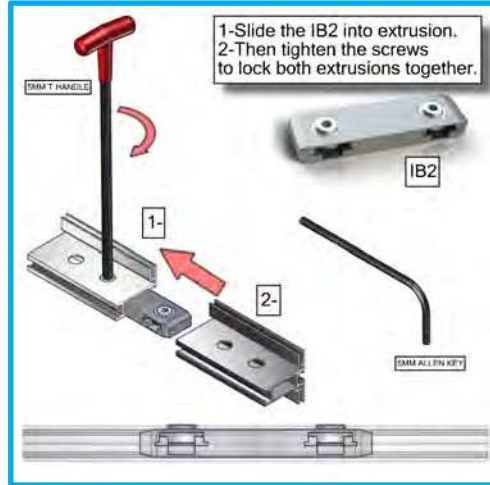
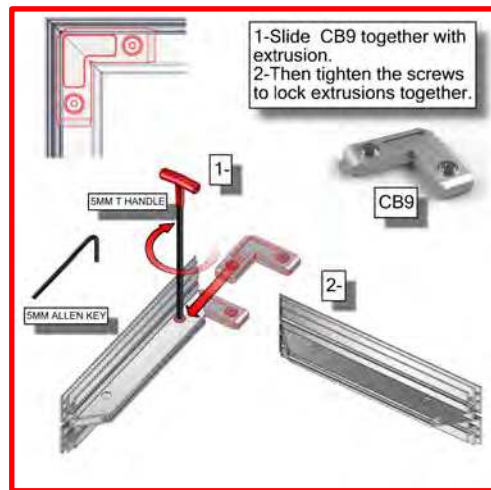

1. Redesign of this exhibit without approval by manufacturer may result in dangerous and unsafe structures. Manufacturer disclaims any responsibility for redesigned exhibits it does not approve in writing.

2. Parts and components such as panels and extrusions are manufactured to metric sizing. Where ever possible sizes have been noted in feet and inches as well as in metric. Below is the imperial to metric sizing table as reference. *Nominal* refers to approximate size.

2400mm = (94 1/2")	Phone Line / Fax
2100mm = (82 5/8")	Internet connection
1800mm = (70 7/8")	Outlet
1500mm = (59")	Main Drop (point of distrution)
1200mm = (47 1/4")	
900mm = (35 1/2")	
600mm = (23 5/8")	
300mm = (11 7/8")	

--- Wire running under carpet

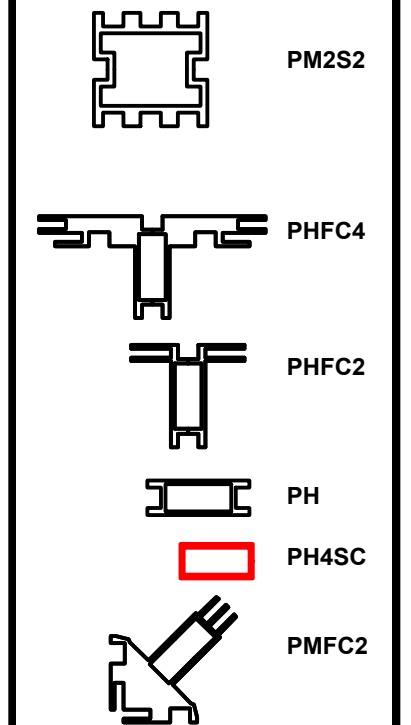

HYBRID PRO RENTAL KIT

Title: SET-UP INSTRUCTIONS

Code	#	Description
R55	2	510MM (20.08") PHFC2 EXTRUSION WITH LOCKS 2 ENDS
R19	4	1155MM (45.47") PHFC2 EXTRUSION WITH IB2 HOLE ONE SIDE-WITH LOCK
IB2	2	PH INLINE CONNECTOR
CB9-S	4	50MM SQUARE PHCF2 CORNER BRACKET

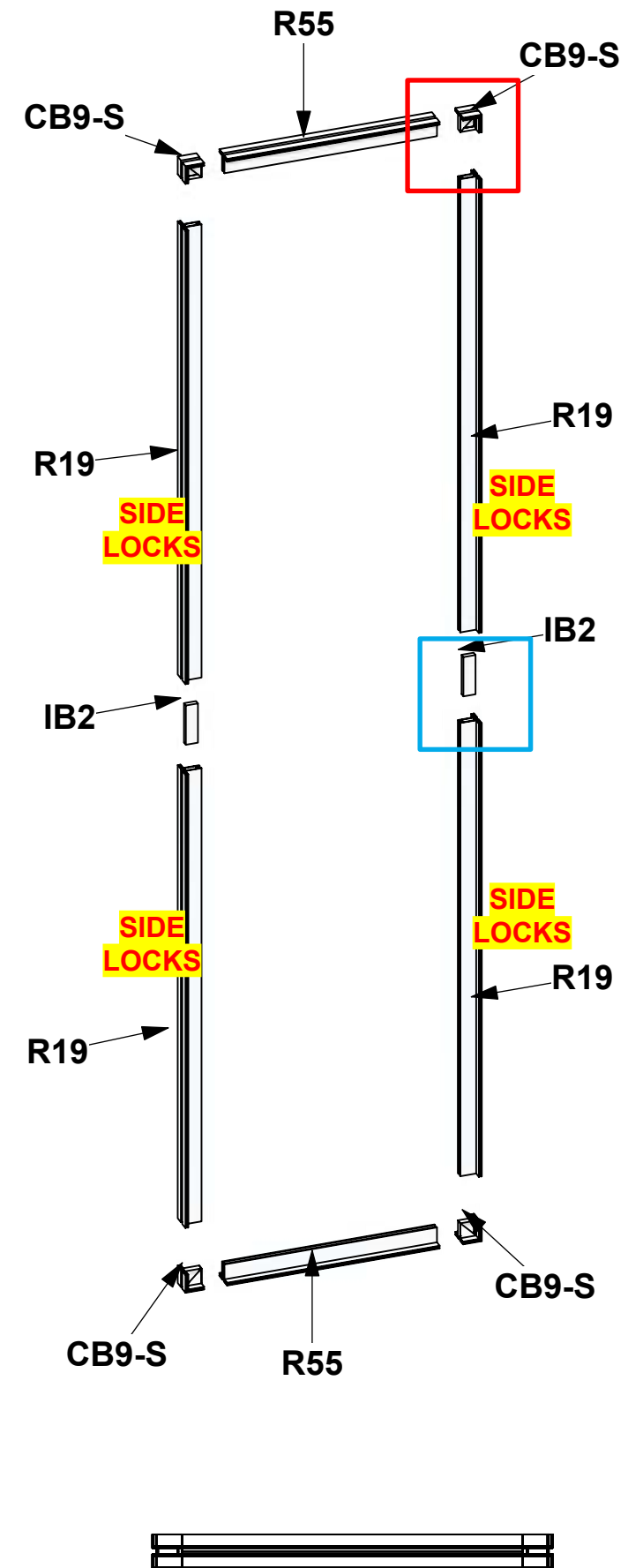
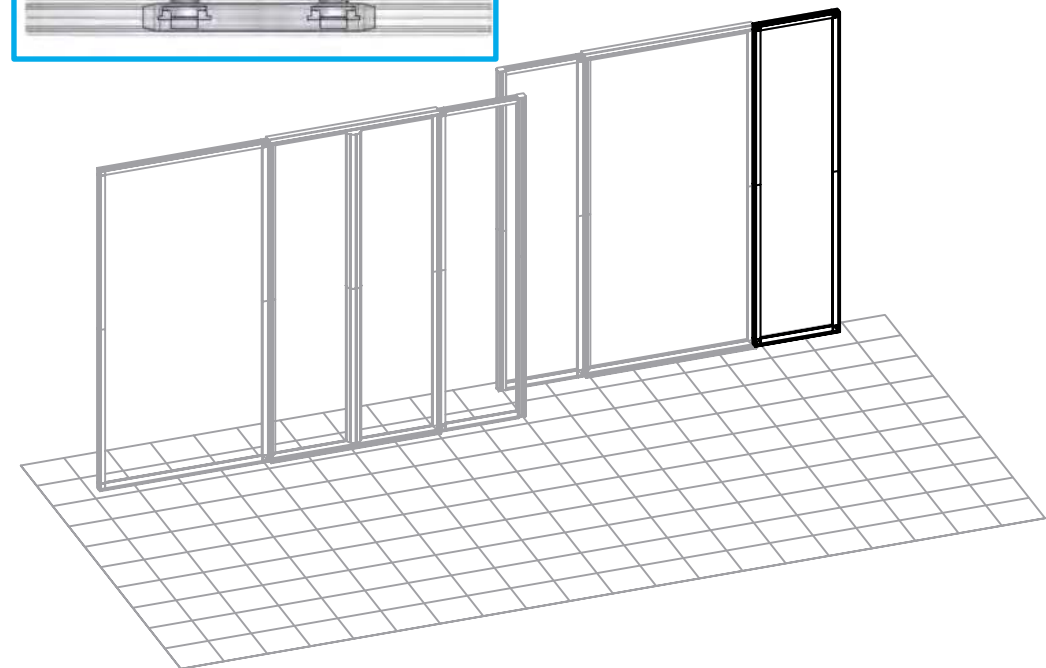
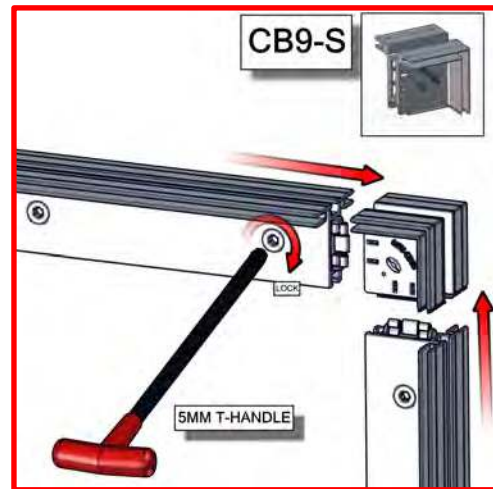

1. Redesign of this exhibit without approval by manufacturer may result in dangerous and unsafe structures. Manufacturer disclaims any responsibility for redesigned exhibits it does not approve in writing.

2. Parts and components such as panels and extrusions are manufactured to metric sizing. Where ever possible sizes have been noted in feet and inches as well as in metric. Below is the imperial to metric sizing table as reference. "Nominal" refers to approximate size.

2400mm = (94 1/2")	Phone Line / Fax
2100mm = (82 5/8")	Internet connection
1800mm = (70 7/8")	Outlet
1500mm = (59")	Main Drop (point of distruption)
1200mm = (47 1/4")	
900mm = (35 1/2")	
600mm = (23 5/8")	
300mm = (11 7/8")	

--- Wire running under carpet

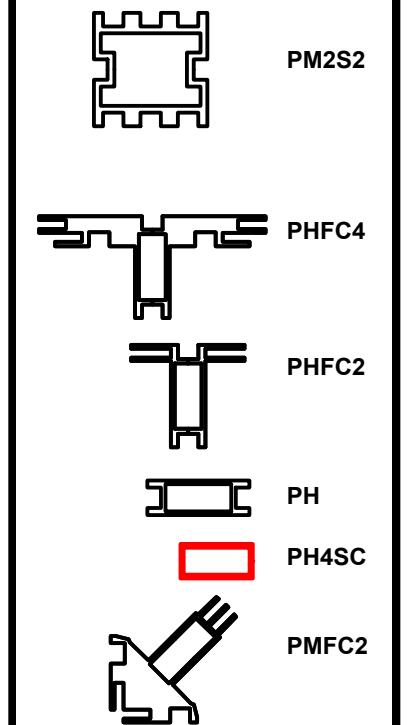

HYBRID PRO RENTAL KIT

Title: SET-UP INSTRUCTIONS

Code	#	Description
R64	2	339MM (13.35") PHFC2 EXTRUSION WITH LOCKS 2 ENDS
R15	6	1200MM (47.24") 100MM PM4S2 SQUARE EXTRUSION WITH PH2 STOP
R13	3	600MM (23.62") PM4D CONNECTOR WITH TENSION GLIDES
R8	2	300MM (11.81") PH EXTRUSION WITH LOCKS 2 ENDS

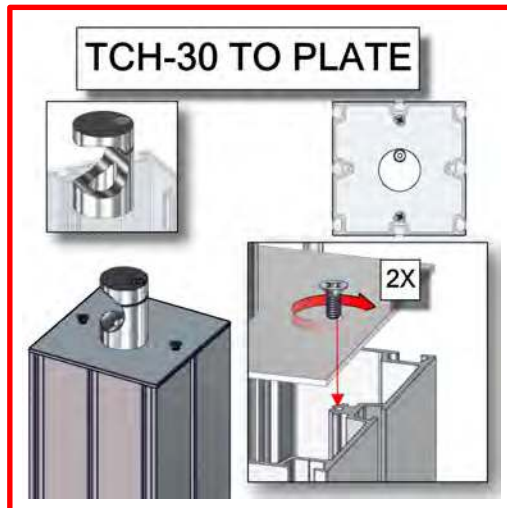
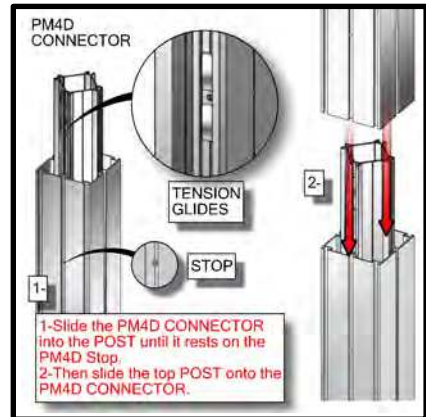

1. Redesign of this exhibit without approval by manufacturer may result in dangerous and unsafe structures. Manufacturer disclaims any responsibility for redesigned exhibits it does not approve in writing.

2. Parts and components such as panels and extrusions are manufactured to metric sizing. Where ever possible sizes have been noted in feet and inches as well as in metric. Below is the imperial to metric sizing table as reference. "Nominal" refers to approximate size.

2400mm = (94 1/2")	Phone Line / Fax
2100mm = (82 5/8")	Internet connection
1800mm = (70 7/8")	Outlet
1500mm = (59")	Main Drop (point of distrution)
1200mm = (47 1/4")	
900mm = (35 1/2")	
600mm = (23 5/8")	
300mm = (11 7/8")	

--- Wire running under carpet

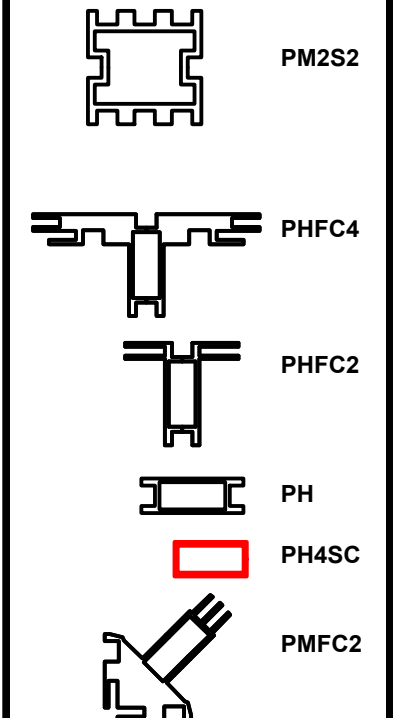
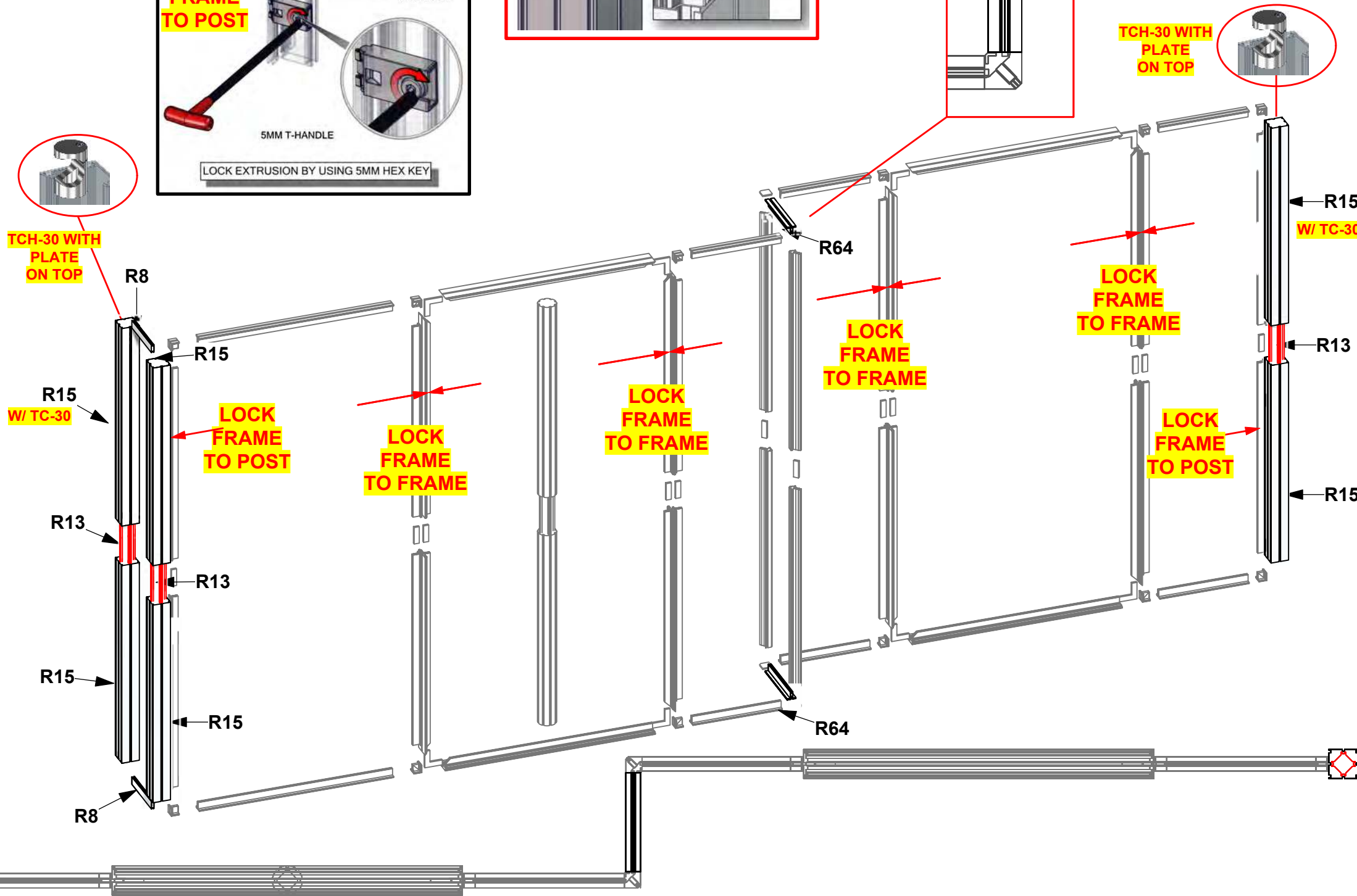

HYBRID PRO RENTAL KIT

Title: SET-UP INSTRUCTIONS

Code	#	Description
GRAPHIC G	1	94.5"H X 23.62"W SINGLE SIDED DYESUB GRAPHIC W/FCE-2 ON PERIMETER
GRAPHIC C	1	94.5"H X 23.82"W SINGLE SIDED DYESUB GRAPHIC W/FCE-2 ON PERIMETER
GRAPHIC A	1	94.5"H X 47.24"W SINGLE SIDED DYESUB GRAPHIC W/FCE-2 ON PERIMETER
GRAPHIC B	1	94.5"H X 47.24"W SINGLE SIDED DYESUB GRAPHIC W/ FCE-2 (SEG) ON PERIMETER
GRAPHIC F	1	94.5"H X 47.24"W SINGLE SIDED DYESUB GRAPHIC W/ FCE-2 (SEG) ON PERIMETER
GRAPHIC E	1	94.5"H X 23.82"W SINGLE SIDED DYESUB GRAPHIC W/FCE-2 ON PERIMETER
GRAPHIC D	1	94.5"H X 15.55"W SINGLE SIDED DYESUB GRAPHIC W/FCE-2 ON PERIMETER
EXT-M-MB	1	MEDIUM MONITOR BRACKET FOR MONITORS 32"-55"

1. Redesign of this exhibit without approval by manufacturer may result in dangerous and unsafe structures. Manufacturer disclaims any responsibility for redesigned exhibits it does not approve in writing.

2. Parts and components such as panels and extrusions are manufactured to metric sizing. Where ever possible sizes have been noted in feet and inches as well as in metric. Below is the imperial to metric sizing table as reference. "Nominal" refers to approximate size.

2400mm = (94 1/2")	Phone Line / Fax
2100mm = (82 5/8")	Internet connection
1800mm = (70 7/8")	Outlet
1500mm = (59")	Main Drop (point of distrution)
1200mm = (47 1/4")	
900mm = (35 1/2")	
600mm = (23 5/8")	
300mm = (11 7/8")	

--- Wire running under carpet

EXT-M-MB

1- INSERT BOLTS INTO MIDDLE CHANNEL. THEN SECURE MONITOR MOUNT WITH WING NUTS.

2- ATTACH MONITOR TO BRACKETS SEE SANUS MANUAL FOR MORE INFO

FABRIC GRAPHIC WITH FCE-2

FCE-2 4 SIDES

1-PUSH FABRIC GRAPHIC INTO ALL 4 SIDES

TOP VIEW

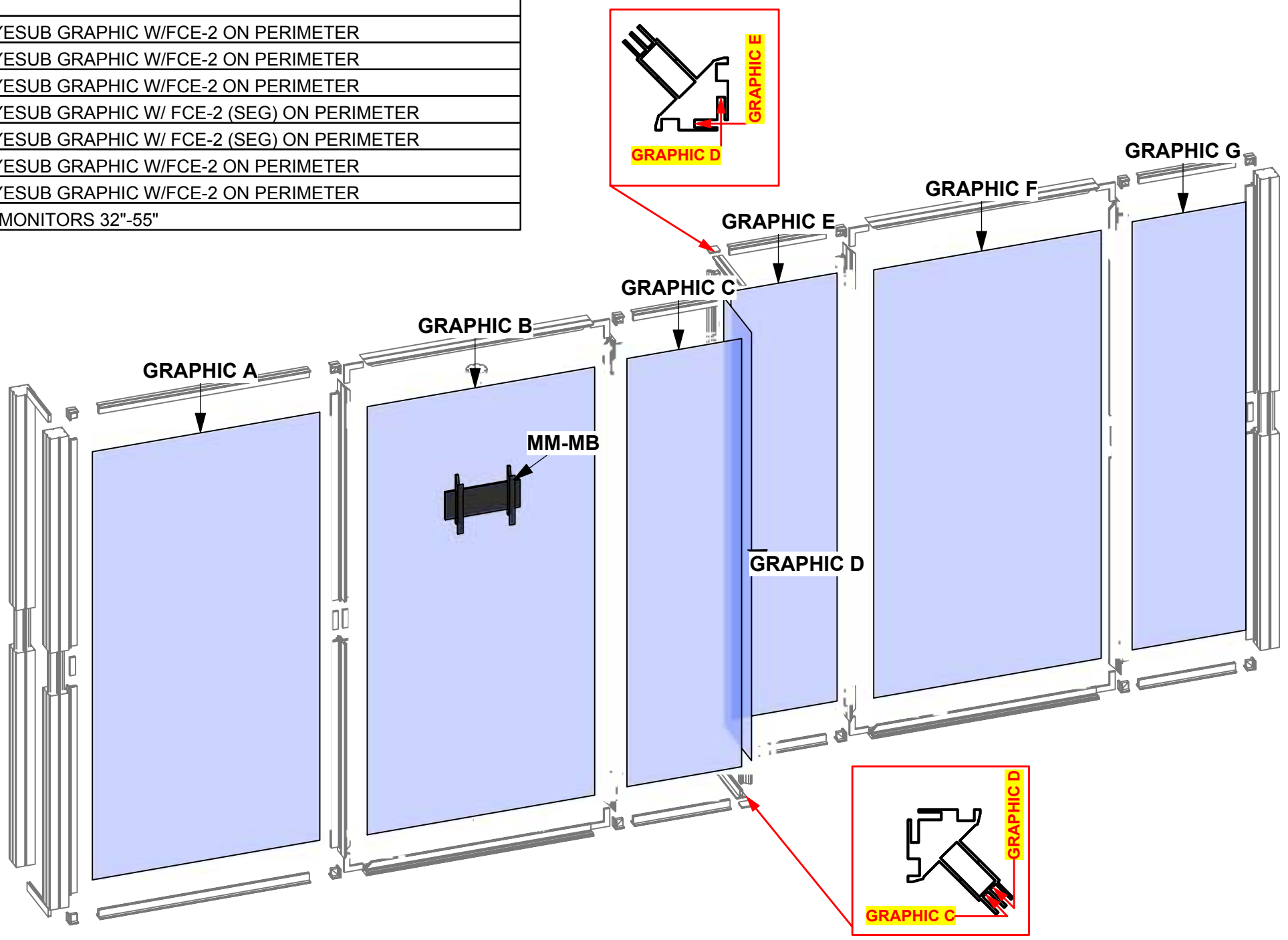

FCE-2 TO PHFC4

START POINT ONE CORNER

Install graphic by pressing the FCE-2 into the channels of PHFC4 extrusion. To pull graphics out of the channels, use tabs on the front side

FCE-2 TO PHFC2

FCE-2 TO PHFC4

FCE-2 TO PHFC2

START POINT ONE CORNER

Install graphic by pressing the FCE-2 into the channels of PHFC2 extrusion. To pull graphics out of the channels, use tabs on the front side

- PM2S2
- PHFC4
- PHFC2
- PH
- PH4SC
- PMFC2

HYBRID PRO RENTAL KIT

Title: SET-UP INSTRUCTIONS

SET UP INSTRUCTIONS:

1. CONNECT BOTTOM AND TOP RAILS FOLLOWING THE LABELS
2. CONNECT SIDE RAILS
3. CLEAN THE FRAME AND PLACE THEM ON CLEAN PLACE
4. CAREFULLY REMOVE FABRIC COVER FROM BAGS
5. PLACE COVER AROUND THE BOTTOM OF THE FRAME
6. PULL COVER CAREFULLY UP TO THE TOP
7. CLOSE ALL ZIPPERS
8. ADJUST FABRIC AROUND THE FRAME

BREAK DOWN INSTRUCTIONS:

REVERSE SET-UP STEPS TO BREAKDOWN FRAME

FABRIC CARE INSTRUCTIONS:

1. UNZIP COVER ZIPPERS
2. CAREFULLY REMOVE FABRIC COVER
3. CLOSE ALL ZIPPERS
4. FOLD OR ROLL NEATLY
5. PLACE FABRIC IN COVER BAG

PART LIST:

- PER UNIT
- 28 30MM DIA. TUBE SECTIONS
 - 36 ES-30 EXPANDING SPIGOT
 - 1 2.5MM HEX KEY
 - 3 TCH-30 CLAMPS
 - 2 TC-30 CLAMPS
 - 1 FABRIC COVER

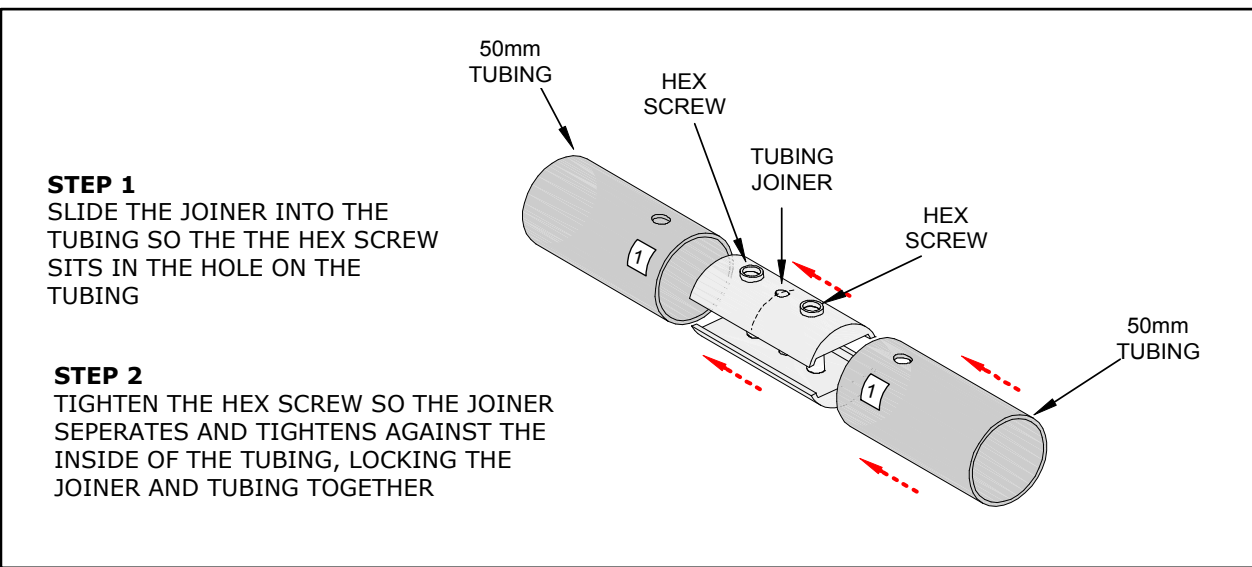
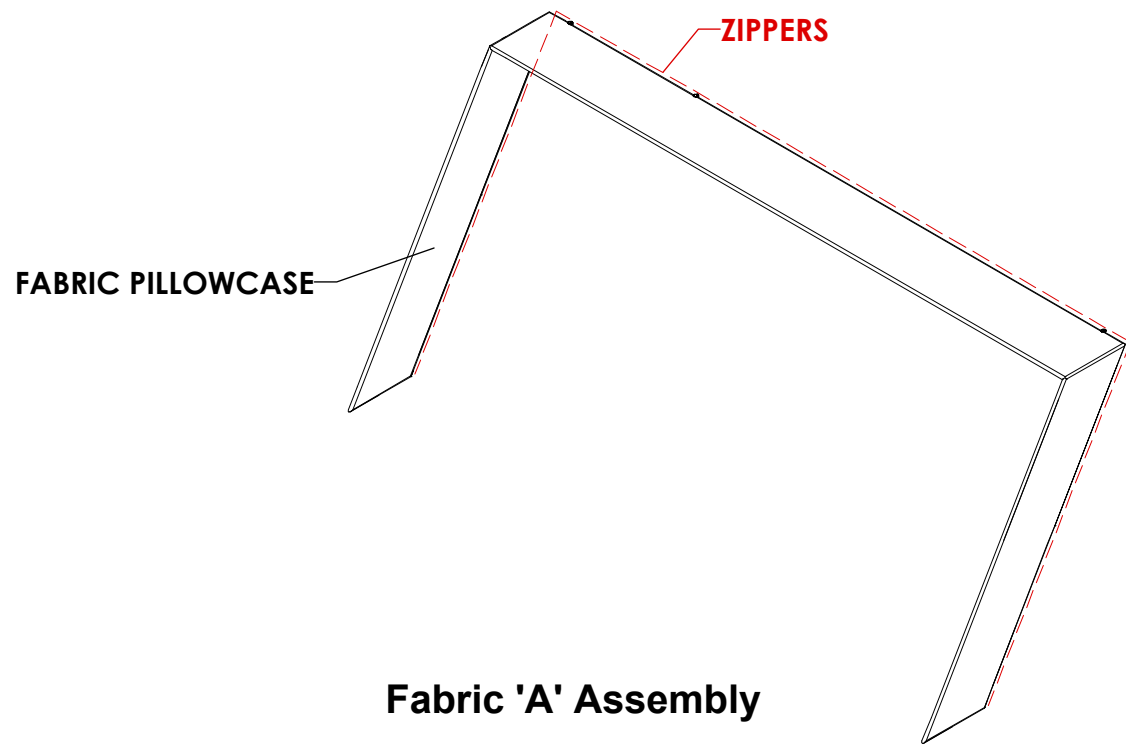
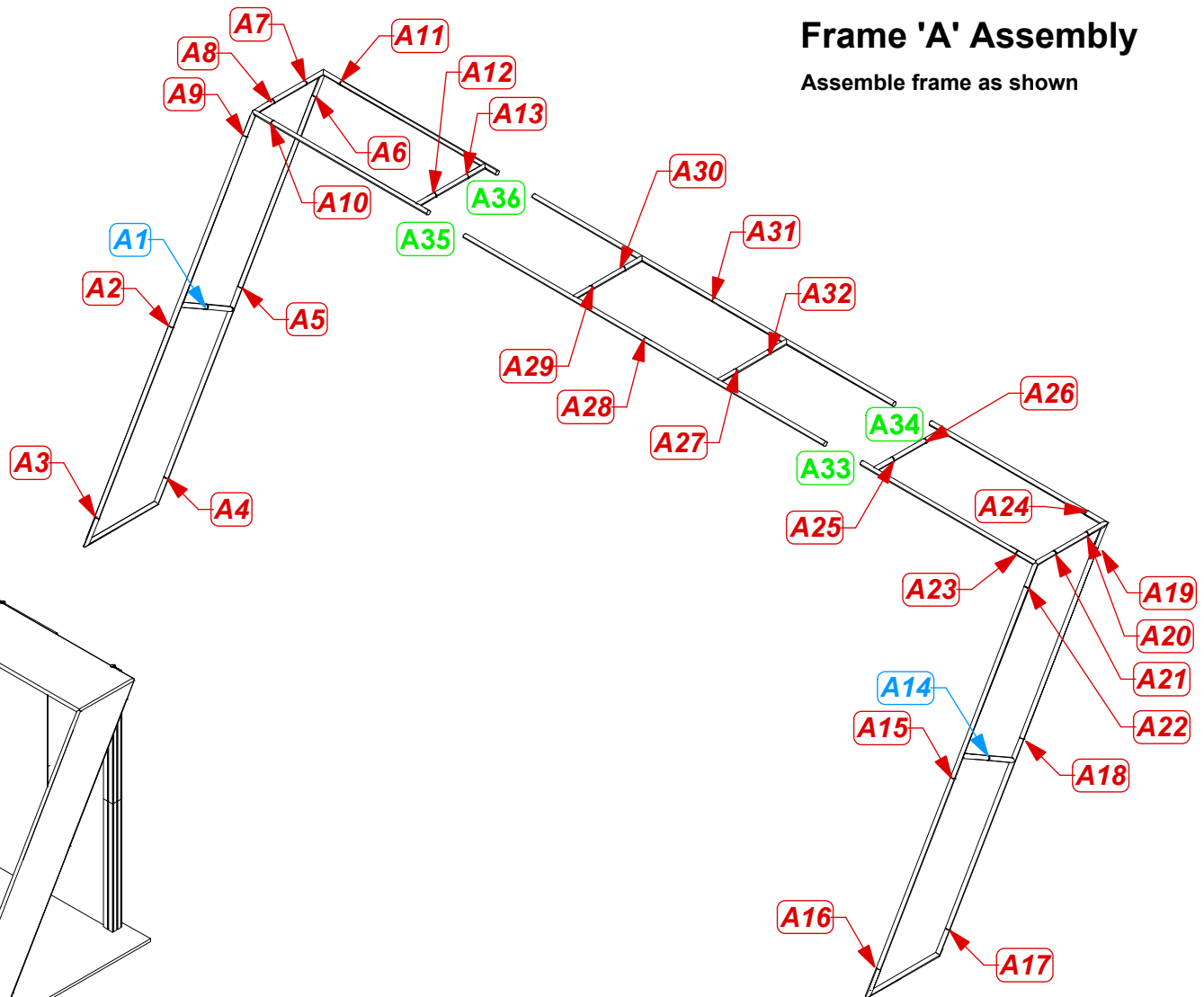
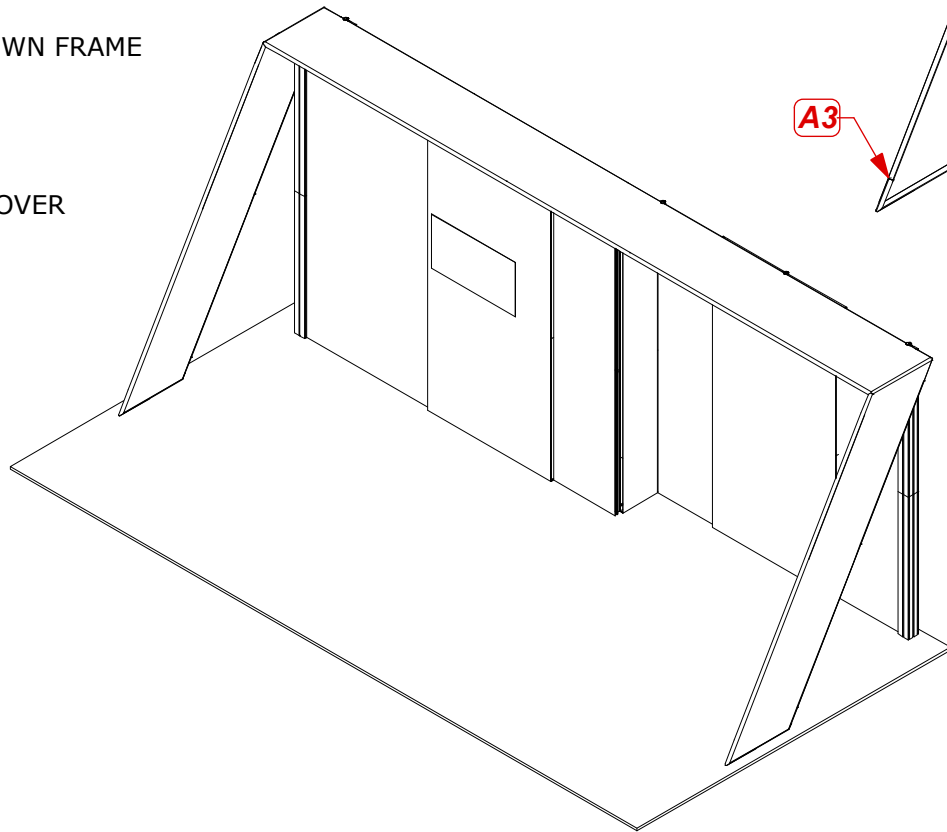

Frame 'A' Assembly

Assemble frame as shown

1. Redesign of this exhibit without approval by manufacturer may result in dangerous and unsafe structures. Manufacturer disclaims any responsibility for redesigned exhibits it does not approve in writing.

2. Parts and components such as panels and extrusions are manufactured to metric sizing. Where ever possible sizes have been noted in feet and inches as well as in metric. Below is the imperial to metric sizing table as reference. "Nominal" refers to approximate size.

2400mm = (94 1/2")	Phone Line / Fax
2100mm = (82 5/8")	Internet connection
1800mm = (70 7/8")	Outlet
1500mm = (59")	Main Drop (point of distrution)
1200mm = (47 1/4")	
900mm = (35 1/2")	
600mm = (23 5/8")	
300mm = (11 7/8")	

--- Wire running under carpet

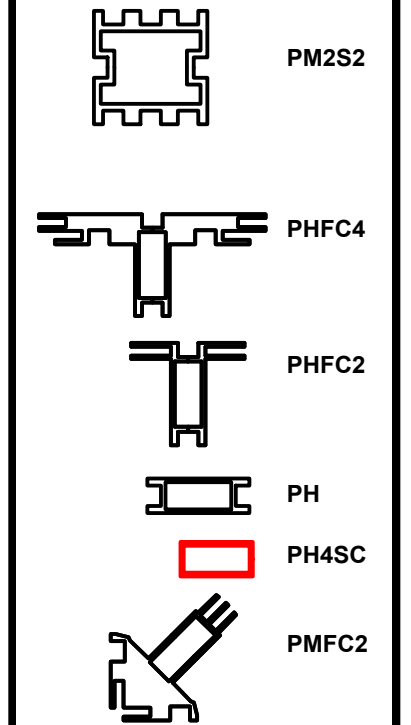

HYBRID PRO RENTAL KIT

Title: SET-UP INSTRUCTIONS

Code	#	Description
CUST-FS	1	APPROX. 230" W X 24" D 30MM TUBE STRUCTURE CANOPY
CUST-FS	2	APPROX. 124" L X 20" D ANGLED 30MM TUBE STRUCTURE
CUSTOM FS	1	ONE PIECE CUSTOM 30MM TUBE FABRIC STRUCTURE



1. Redesign of this exhibit without approval by manufacturer may result in dangerous and unsafe structures. Manufacturer disclaims any responsibility for redesigned exhibits it does not approve in writing.

2. Parts and components such as panels and extrusions are manufactured to metric sizing. Where ever possible sizes have been noted in feet and inches as well as in metric. Below is the imperial to metric sizing table as reference. "Nominal" refers to approximate size.

2400mm = (94 1/2")	Phone Line / Fax
2100mm = (82 5/8")	Internet connection
1800mm = (70 7/8")	Outlet
1500mm = (59")	Main Drop (point of distrution)
1200mm = (47 1/4")	
900mm = (35 1/2")	
600mm = (23 5/8")	
300mm = (11 7/8")	

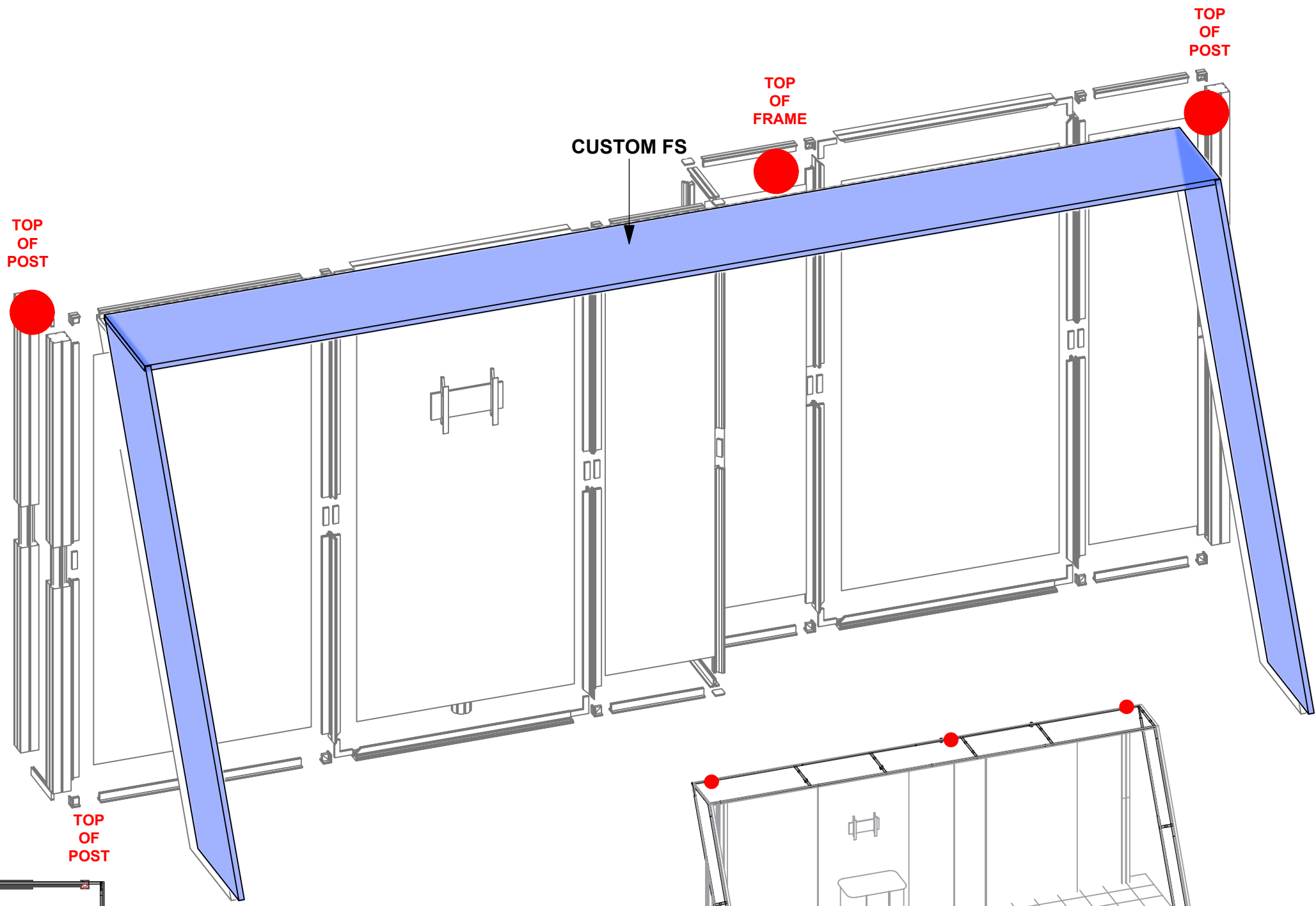
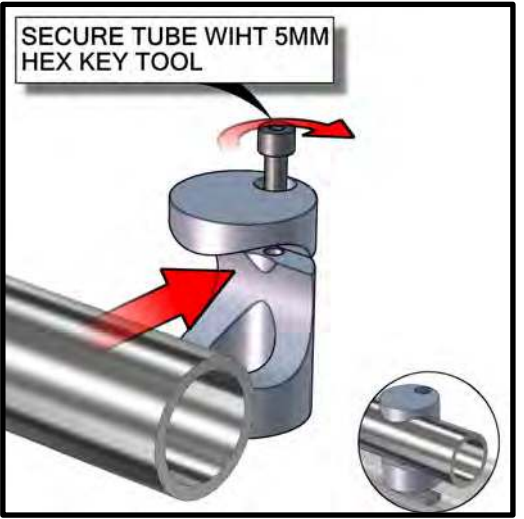
--- Wire running under carpet

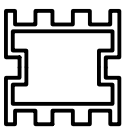
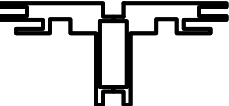
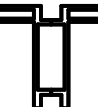

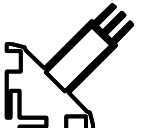
-  PM2S2
-  PHFC4
-  PHFC2
-  PH
-  PH4SC
-  PMFC2

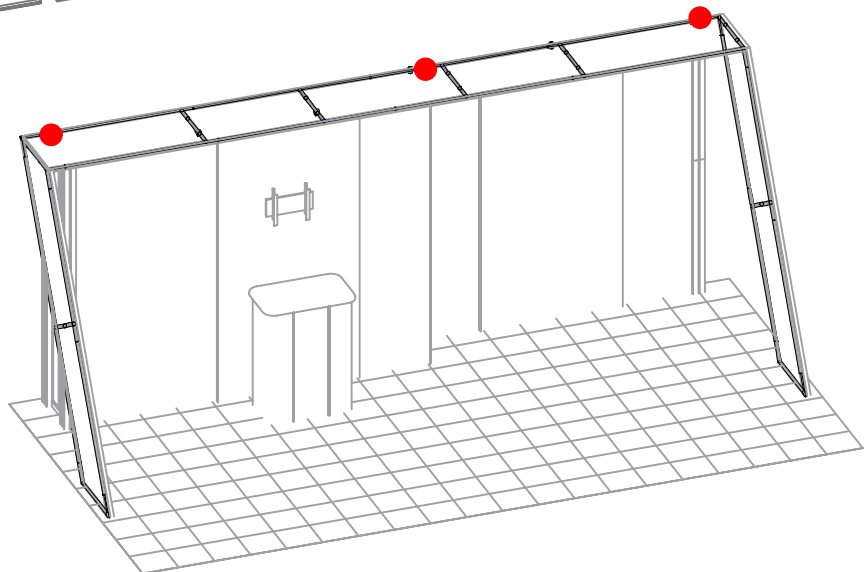
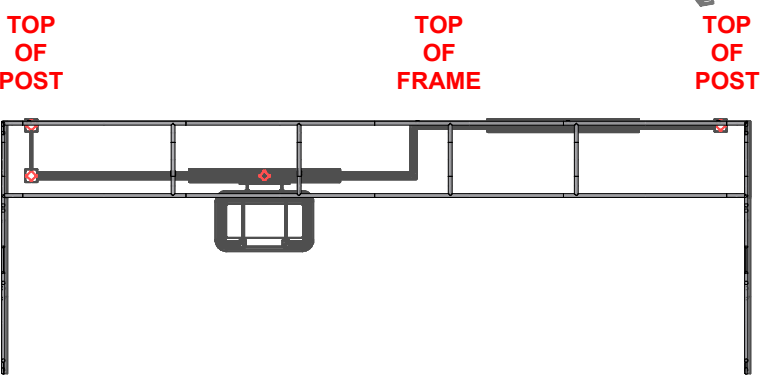

HYBRID PRO RENTAL KIT

Title: SET-UP INSTRUCTIONS

R-VFC-04

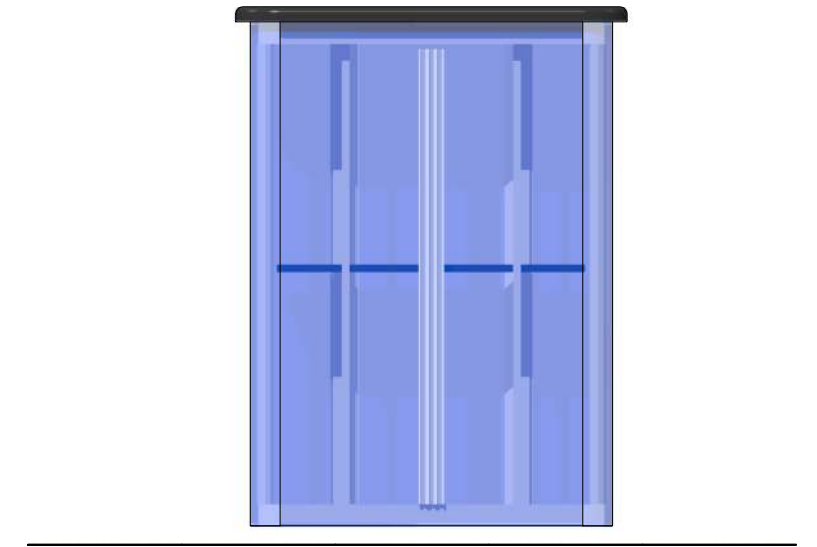
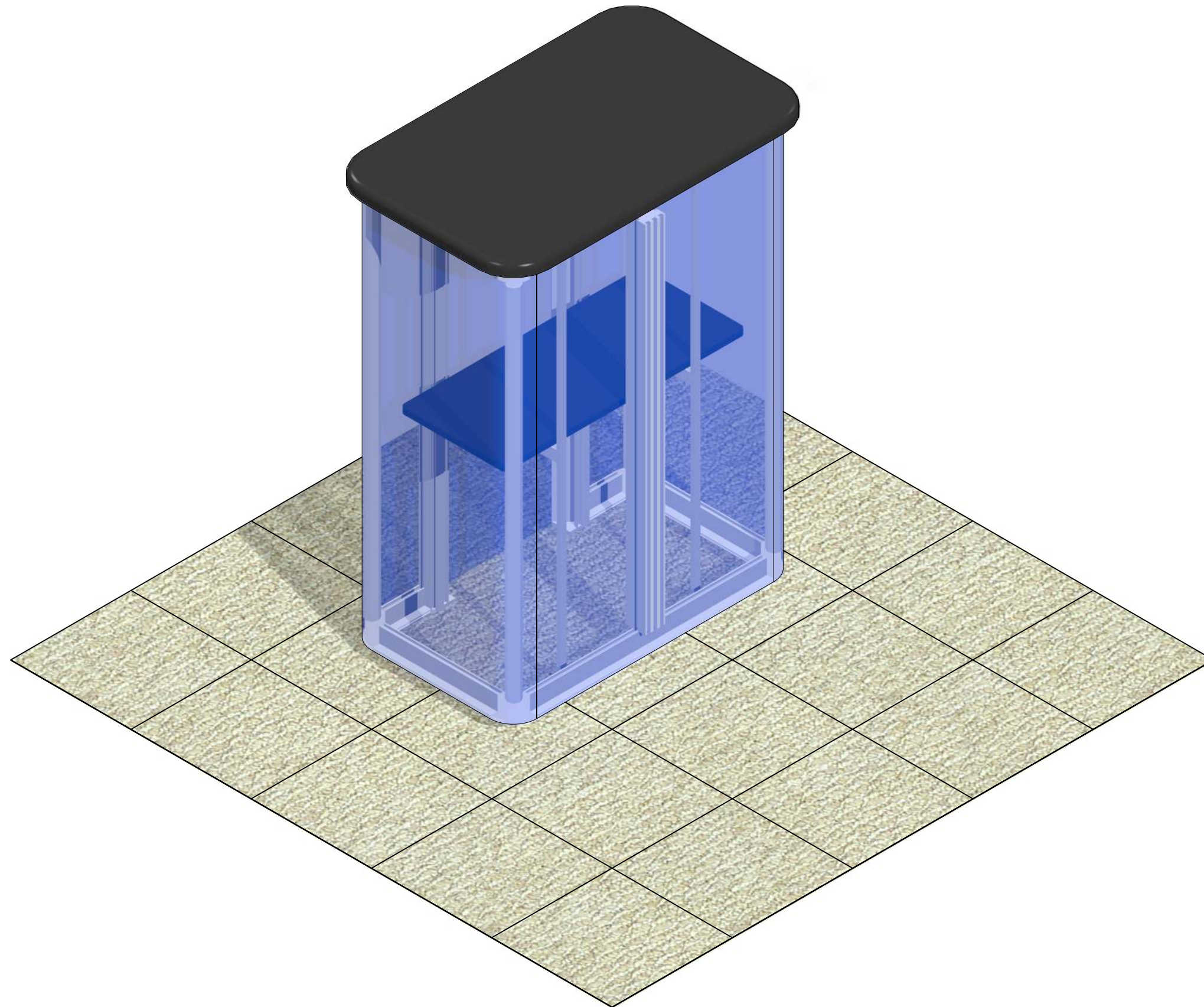

Code	#	Description
GRAPHIC	1	43 3/8" (H) X 15 1/2" (W) SINGLE SIDED DYESUB GRAPHIC W/ FCE-2 (SEG) ON PERIMETER
R6	4	300MM (11.81") PHFC2 EXTRUSION WITH LOCKS 2 ENDS
R5	4	100MM (3.94") PHFC2 EXTRUSION WITH LOCKS 2 ENDS
R109	4	910MM LENGTH 30mm (1.18 Inch) TUBE
R4	2	600MM (23.62") PHFC2 EXTRUSION WITH LOCKS 2 ENDS
VFC-04-CT	1	3' X 2' LAMINATE COUNTER TOP [BLACK THERMAFORM]
R3	2	986MM (38.82") PMFC2-90 EXTRUSION-WITH LOCKS BOTH ENDS
PMFC2-90 CAP	4	PMFC2 90 DEGREE EXTRUSION CAP
R2	4	288MM (11.34") PH1 EXTRUSION WITH LOCKS 2 ENDS
R1	1	910MM (35.82") 50MM PM2S SQUARE EXTRUSION WITH LOCKS 2 ENDS
VFC-04-CT-S	1	INTERNAL SHELF FOR VECTOR COUNTER VFC-04
GRAPHIC	1	43 3/8" (H) X 77 1/4" (W) SINGLE SIDED DYESUB GRAPHIC W/ FCE-2 (SEG) ON PERIMETER
PE-1000	2	1000MM (39.37") PE EXTRUSION
CB10-R	8	50MM ROUND PHCF2 CORNER BRACKET

BOM

R-VFC-04

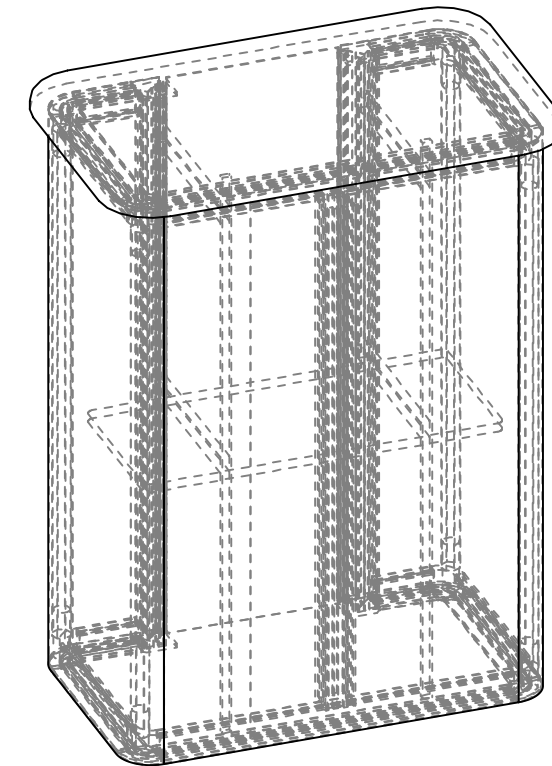
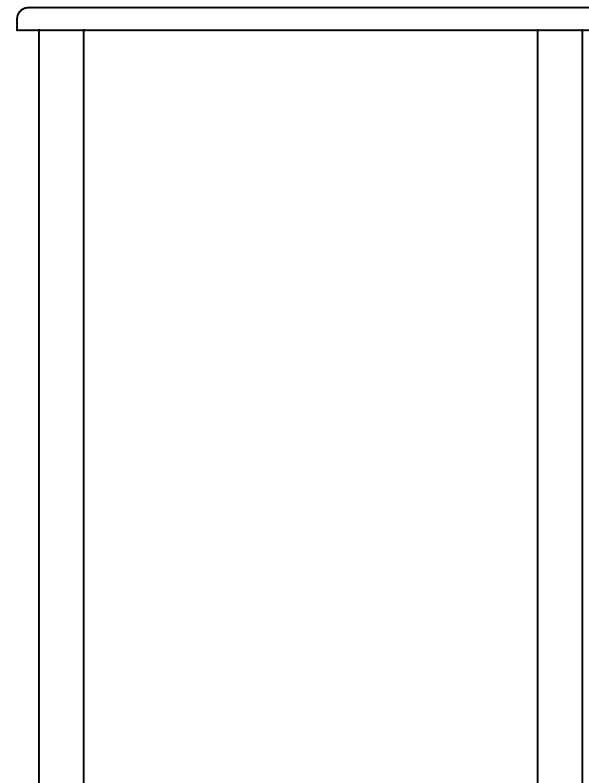
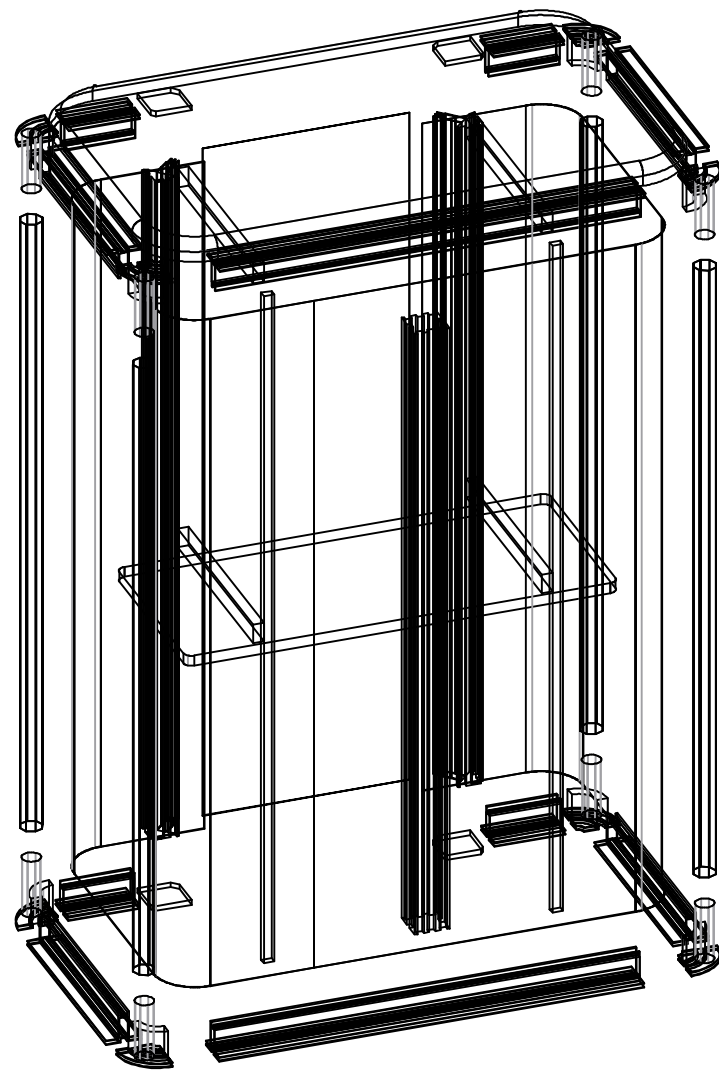
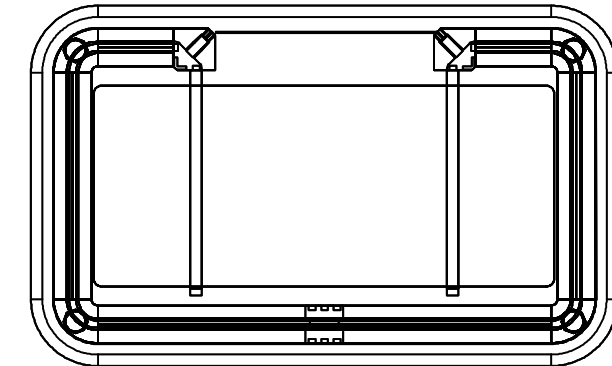





1. Redesign of this exhibit without approval by manufacturer may result in dangerous and unsafe structures. Manufacturer disclaims any responsibility for redesigned exhibits it does not approve in writing.

2. Parts and components such as panels and extrusions are manufactured to metric sizing. Where ever possible sizes have been noted in feet and inches as well as in metric. Below is the imperial to metric sizing table as reference. "Nominal" refers to approximate size.

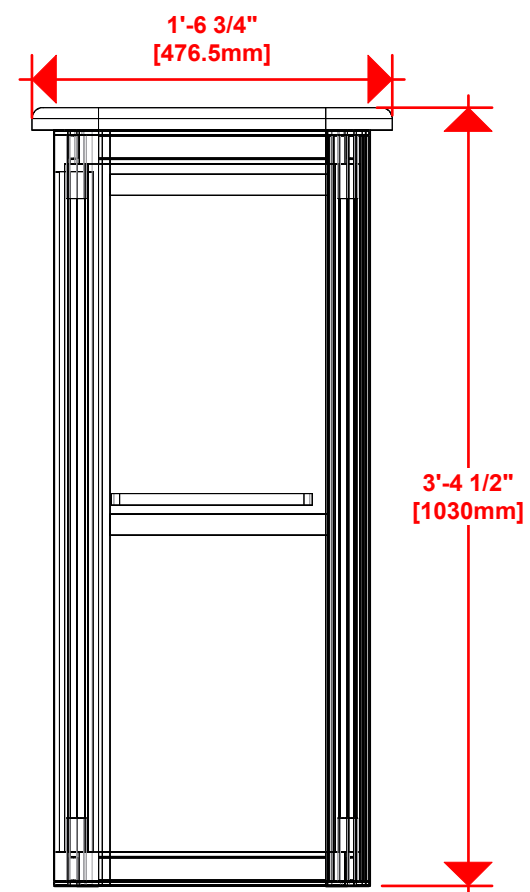
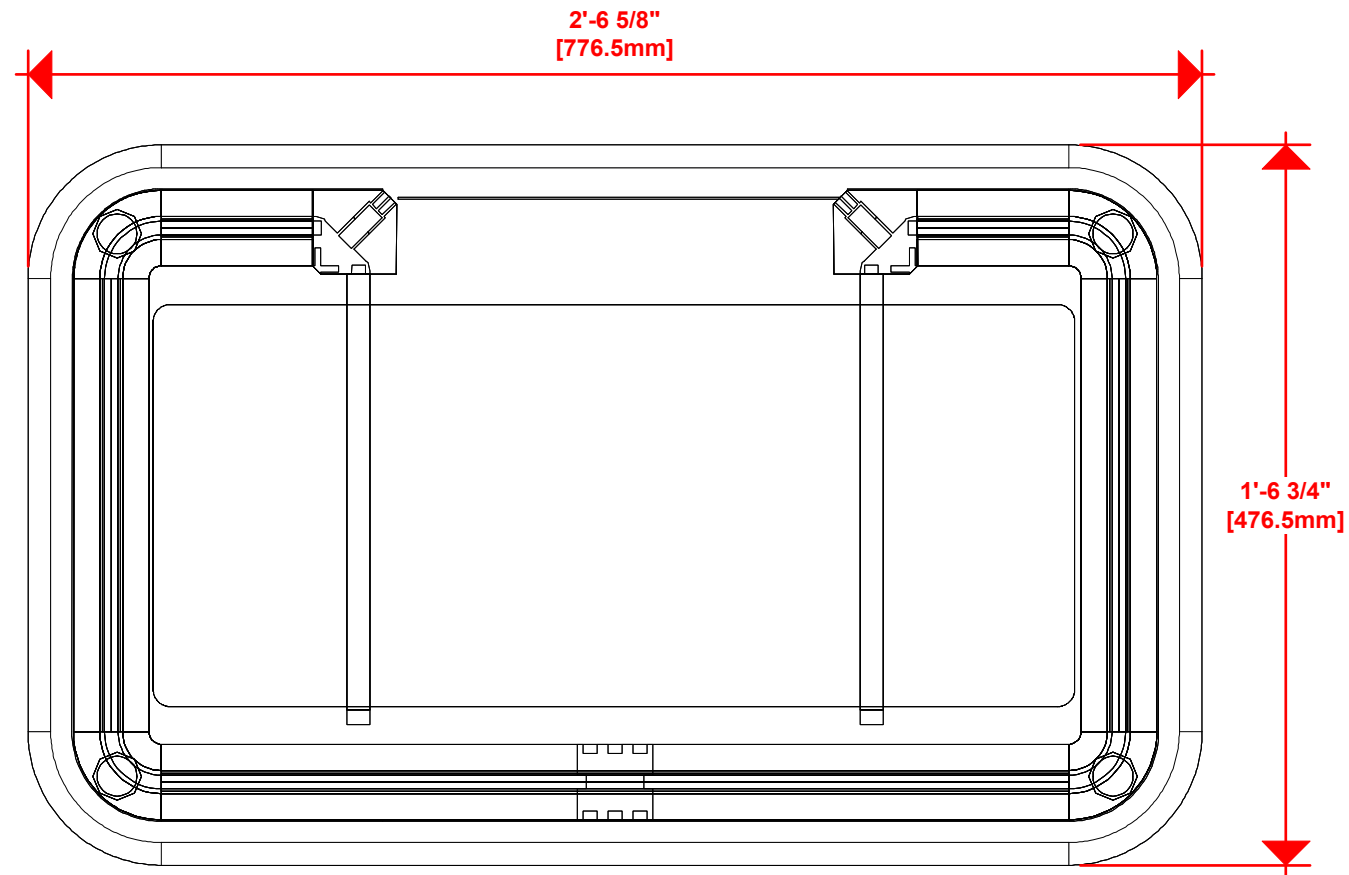
2400mm = (94 1/2")	☒ Phone Line / Fax
2100mm = (82 5/8")	☒ Internet connection
1800mm = (70 7/8")	☒ Outlet
1500mm = (59")	☒ Main Drop (point of distrution)
1200mm = (47 1/4")	
900mm = (35 1/2")	
600mm = (23 5/8")	
300mm = (11 7/8")	

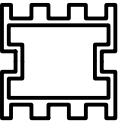
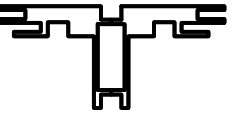
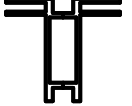
--- Wire running under carpet

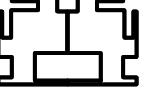
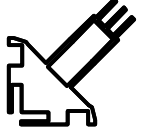

-  PM2S2
-  PHFC4
-  PHFC2
-  PH
-  PH4SC
-  PH1
-  PMFC2-T
-  PMFC2-90

HYBRID PRO RENTAL KIT

Title: SET-UP INSTRUCTIONS

Code	#	Description
R6	4	300MM (11.81") PHFC2 EXTRUSION WITH LOCKS 2 ENDS
R109	4	910MM LENGTH 30mm (1.18 Inch) TUBE
CB10-R	8	50MM ROUND PHCF2 CORNER BRACKET

1. Redesign of this exhibit without approval by manufacturer may result in dangerous and unsafe structures. Manufacturer disclaims any responsibility for redesigned exhibits it does not approve in writing.

2. Parts and components such as panels and extrusions are manufactured to metric sizing. Where ever possible sizes have been noted in feet and inches as well as in metric. Below is the imperial to metric sizing table as reference. "Nominal" refers to approximate size.

2400mm = (94 1/2")	Phone Line / Fax
2100mm = (82 5/8")	Internet connection
1800mm = (70 7/8")	Outlet
1500mm = (59")	Main Drop (point of distrution)
1200mm = (47 1/4")	
900mm = (35 1/2")	
600mm = (23 5/8")	
300mm = (11 7/8")	

--- Wire running under carpet

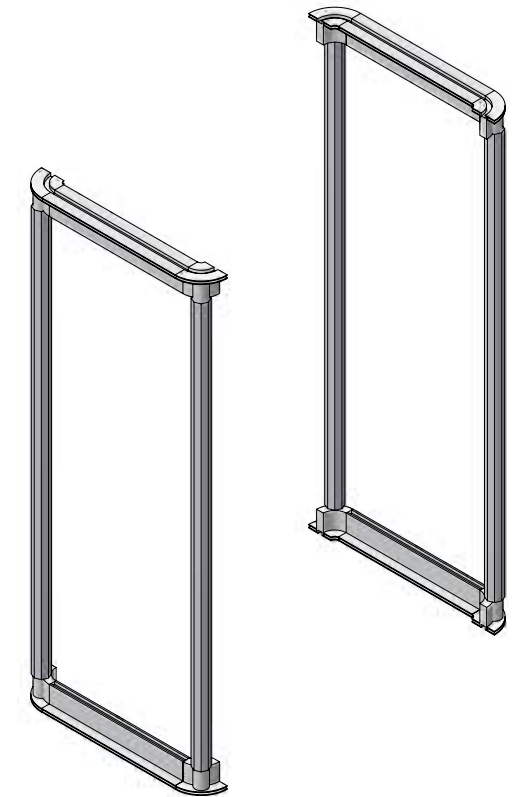
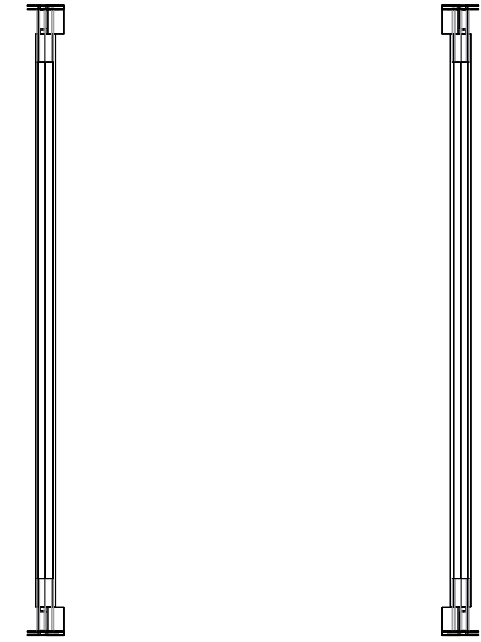
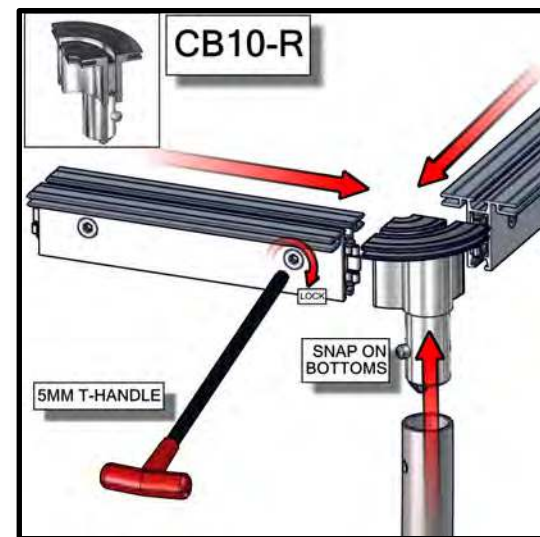
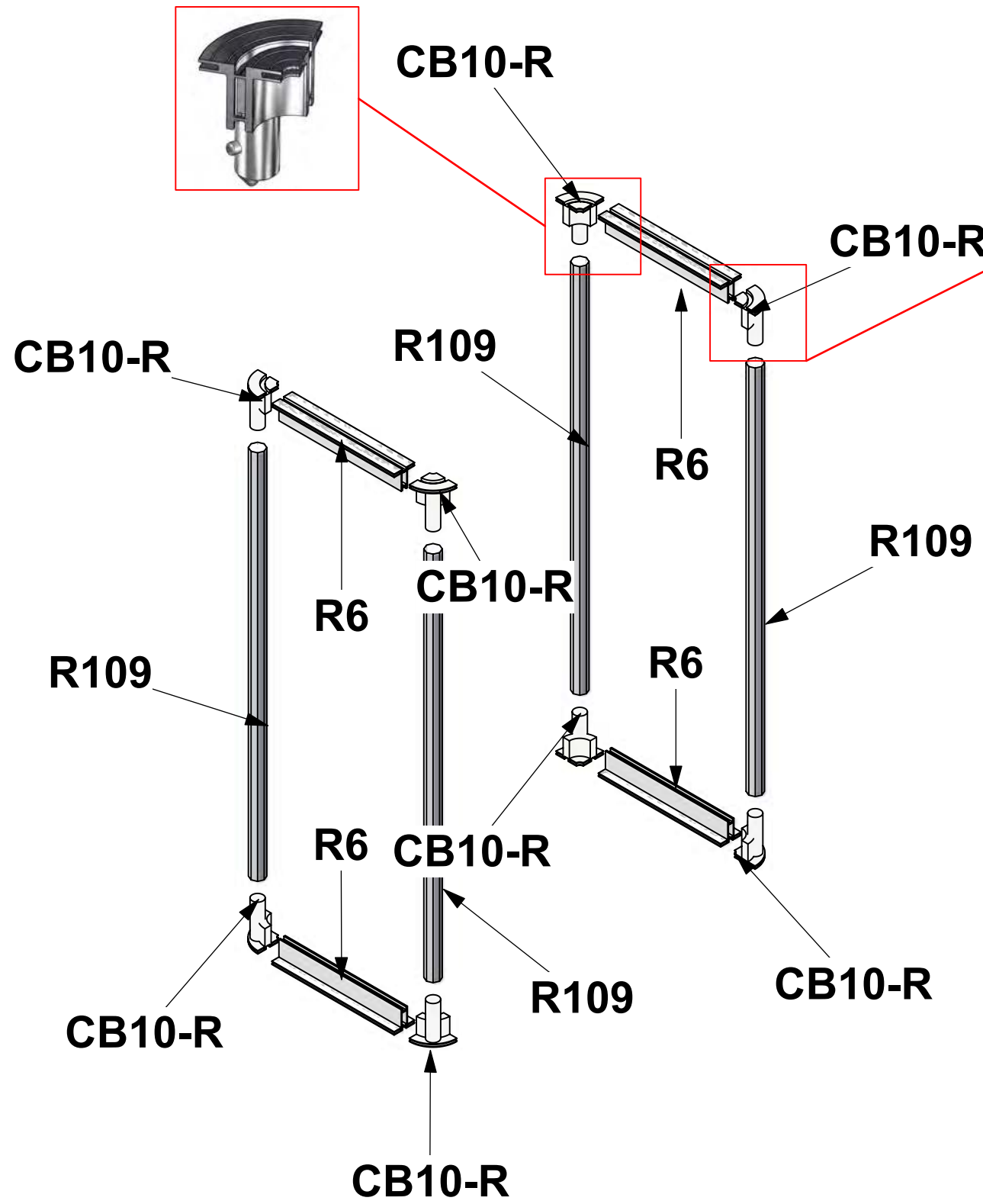

- PM2S2
- PHFC4
- PHFC2
- PH
- PH4SC
- PH1
- PMFC2-T
- PMFC2-90

HYBRID PRO RENTAL KIT

Title: SET-UP INSTRUCTIONS

BUILD 2 UNITS

Code	#	Description
R5	4	100MM (3.94") PHFC2 EXTRUSION WITH LOCKS 2 ENDS
R4	2	600MM (23.62") PHFC2 EXTRUSION WITH LOCKS 2 ENDS
R3	2	986MM (38.82") PMFC2-90 EXTRUSION-WITH LOCKS BOTH ENDS
PMFC2-90 CA	4	PMFC2 90 DEGREE EXTRUSION CAP
R1	1	910MM (35.82") 50MM PM2S SQUARE EXTRUSION WITH LOCKS 2 ENDS

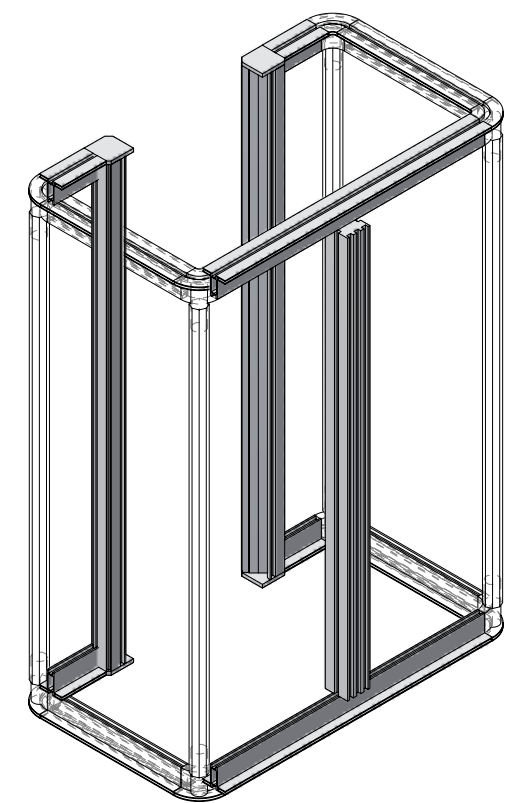
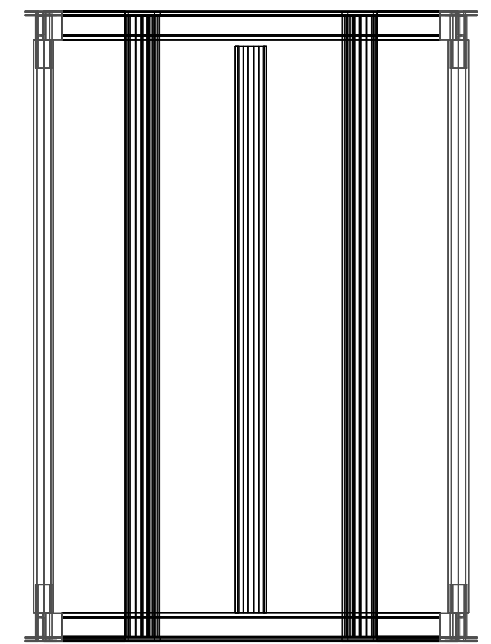
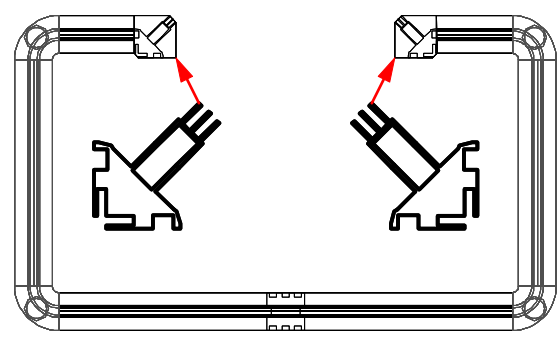
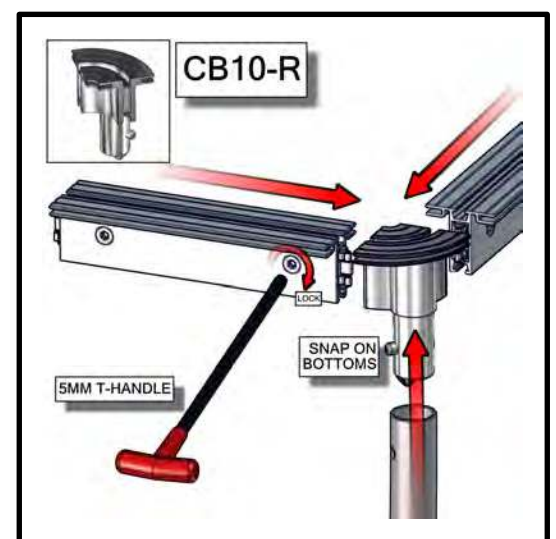
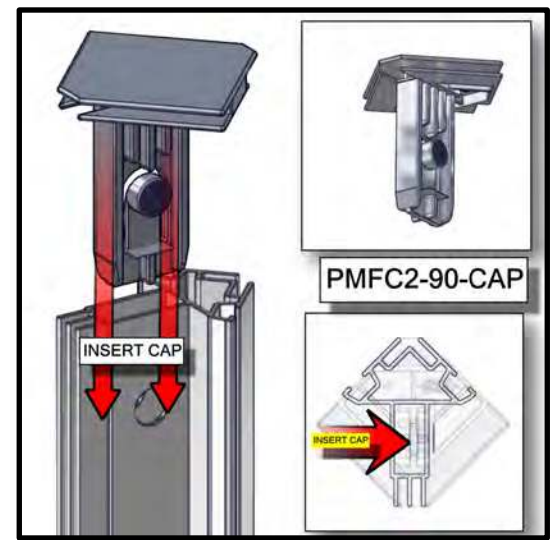
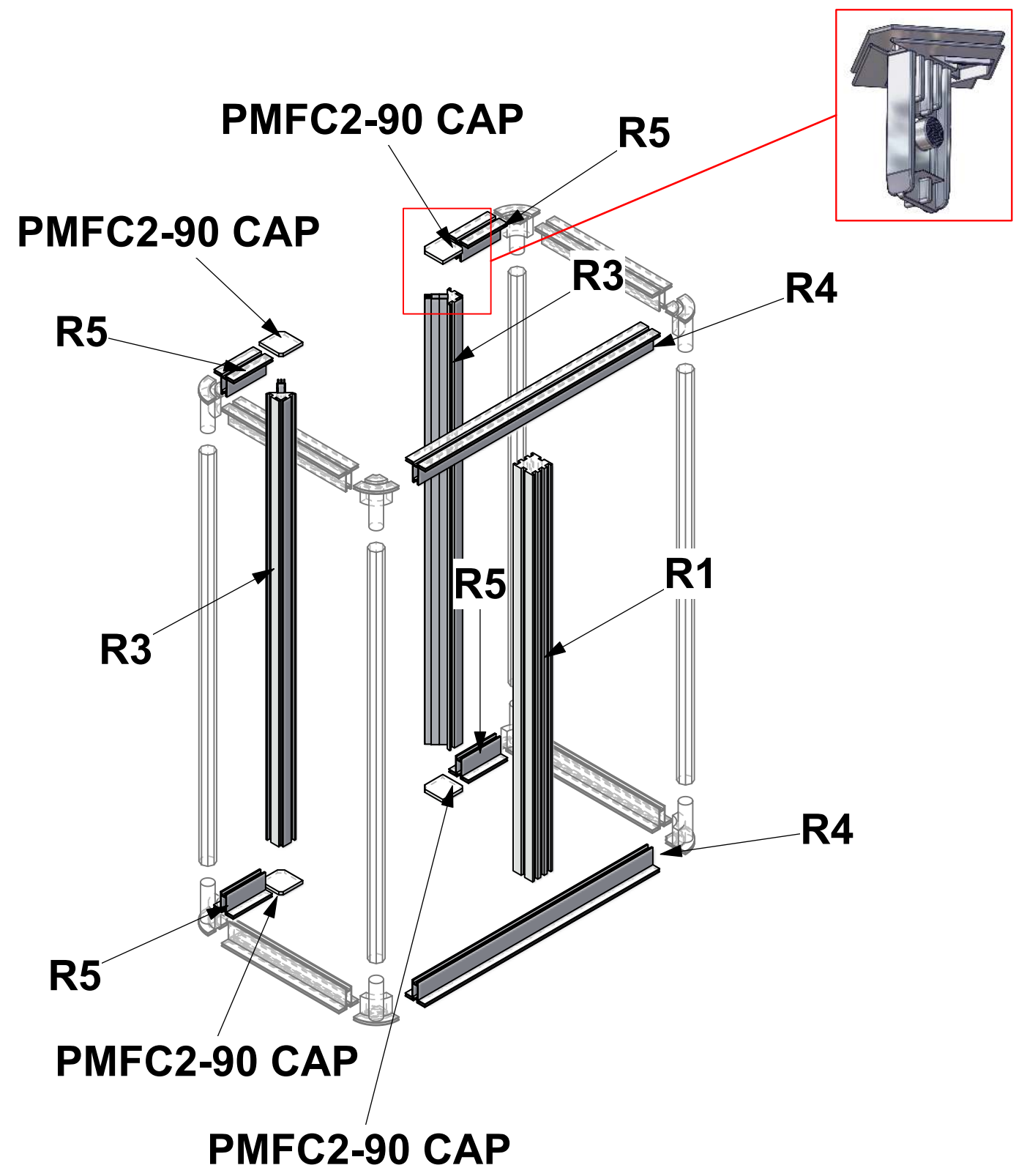

1. Redesign of this exhibit without approval by manufacturer may result in dangerous and unsafe structures. Manufacturer disclaims any responsibility for redesigned exhibits it does not approve in writing.

2. Parts and components such as panels and extrusions are manufactured to metric sizing. Where ever possible sizes have been noted in feet and inches as well as in metric. Below is the imperial to metric sizing table as reference. "Nominal" refers to approximate size.

2400mm = (94 1/2")	Phone Line / Fax
2100mm = (82 5/8")	Internet connection
1800mm = (70 7/8")	Outlet
1500mm = (59")	Main Drop (point of distrution)
1200mm = (47 1/4")	
900mm = (35 1/2")	
600mm = (23 5/8")	
300mm = (11 7/8")	

--- Wire running under carpet

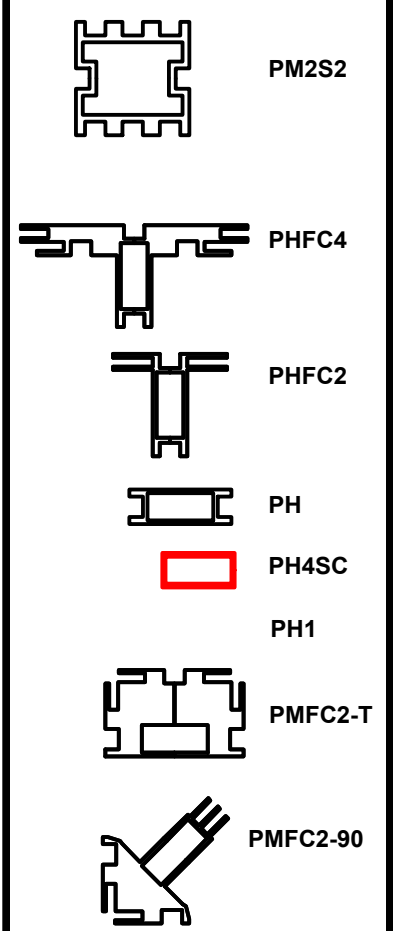

HYBRID PRO RENTAL KIT

Title: SET-UP INSTRUCTIONS

Code	#	Description
R2	4	288MM (11.34") PH1 EXTRUSION WITH LOCKS 2 ENDS
VFC-04-CT-S	1	INTERNAL SHELF FOR VECTOR COUNTER VFC-04
PE-1000	2	1000MM (39.37") PE EXTRUSION

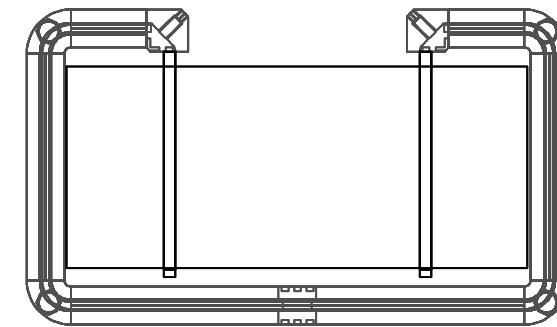

1. Redesign of this exhibit without approval by manufacturer may result in dangerous and unsafe structures. Manufacturer disclaims any responsibility for redesigned exhibits it does not approve in writing.

2. Parts and components such as panels and extrusions are manufactured to metric sizing. Where ever possible sizes have been noted in feet and inches as well as in metric. Below is the imperial to metric sizing table as reference. "Nominal" refers to approximate size.

2400mm = (94 1/2")	Phone Line / Fax
2100mm = (82 5/8")	Internet connection
1800mm = (70 7/8")	Outlet
1500mm = (59")	Main Drop (point of distrution)
1200mm = (47 1/4")	
900mm = (35 1/2")	
600mm = (23 5/8")	
300mm = (11 7/8")	

--- Wire running under carpet

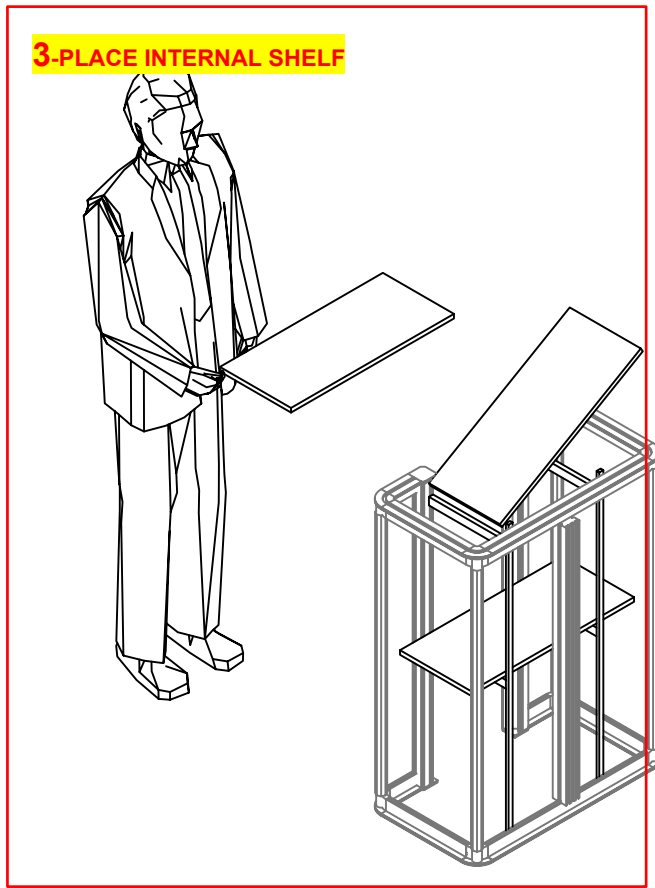
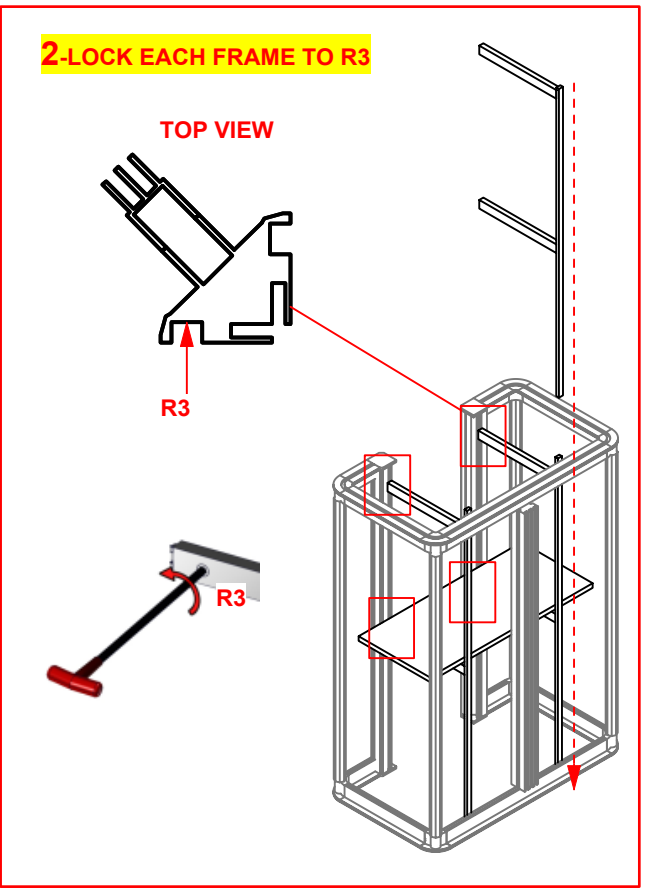
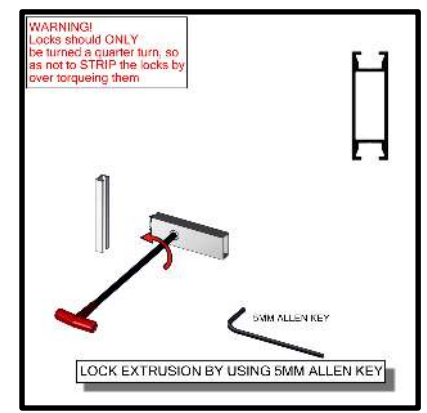
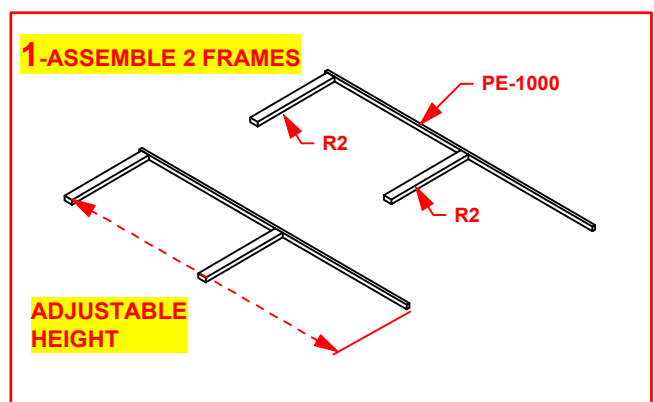
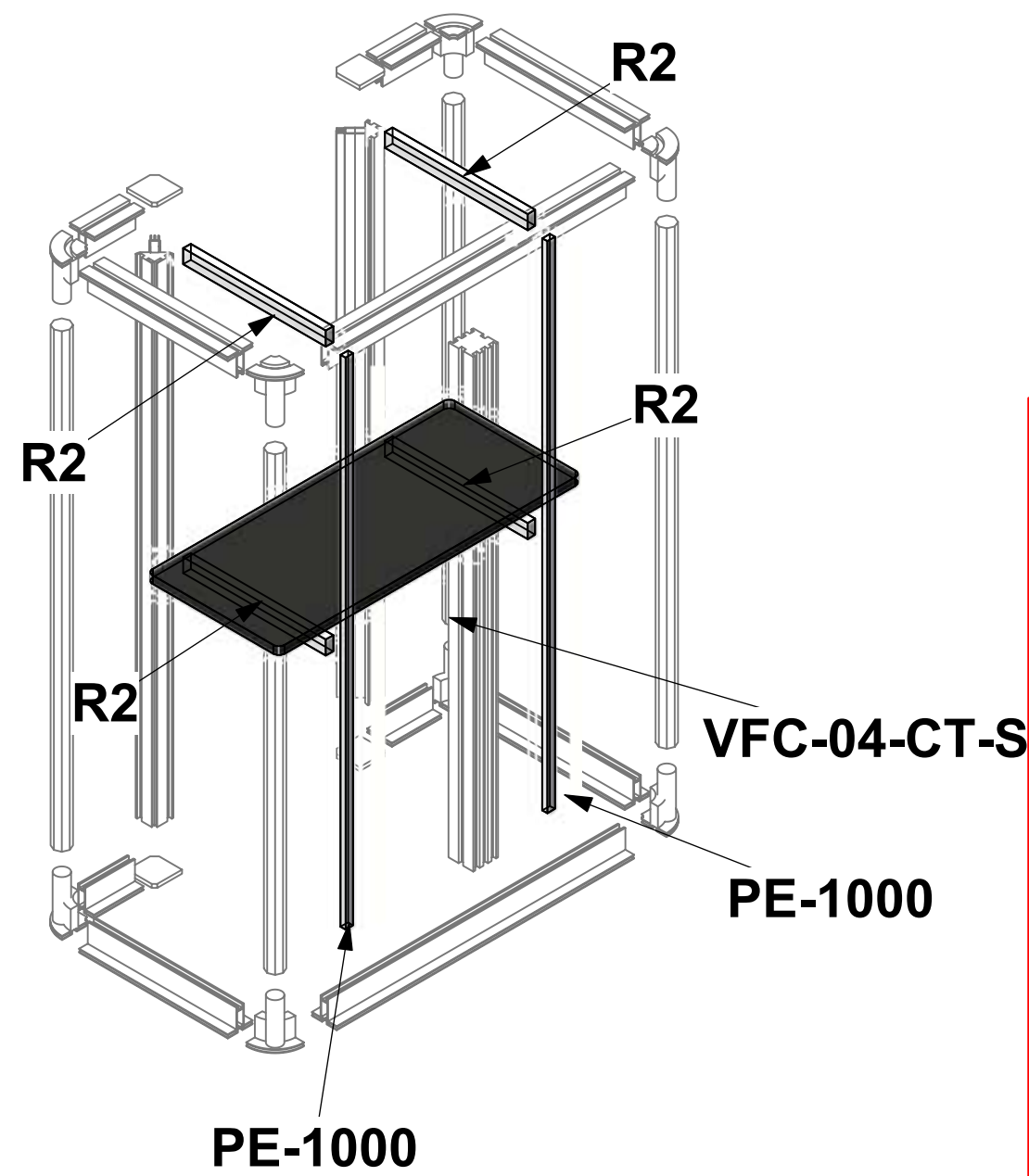

- PM2S2
- PHFC4
- PHFC2
- PH
- PH4SC
- PH1
- PMFC2-T
- PMFC2-90

HYBRID PRO RENTAL KIT

Title: SET-UP INSTRUCTIONS

Code	#	Description
GRAPHIC	1	43 3/8" (H) X 15 1/2" (W) SINGLE SIDED DYESUB GRAPHIC W/ FCE-2 (SEG) ON PE
VFC-04-CT	1	3' X 2' LAMINATE COUNTER TOP [BLACK THERMAFORM]
GRAPHIC	1	43 3/8" (H) X 77 1/4" (W) SINGLE SIDED DYESUB GRAPHIC W/ FCE-2 (SEG) ON PE





1. Redesign of this exhibit without approval by manufacturer may result in dangerous and unsafe structures. Manufacturer disclaims any responsibility for redesigned exhibits it does not approve in writing.

2. Parts and components such as panels and extrusions are manufactured to metric sizing. Where ever possible sizes have been noted in feet and inches as well as in metric. Below is the imperial to metric sizing table as reference. "Nominal" refers to approximate size.

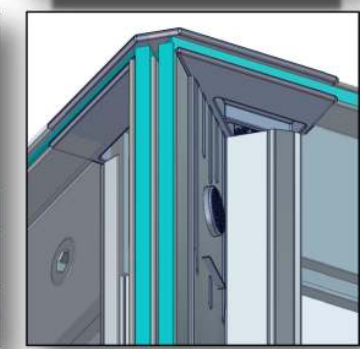
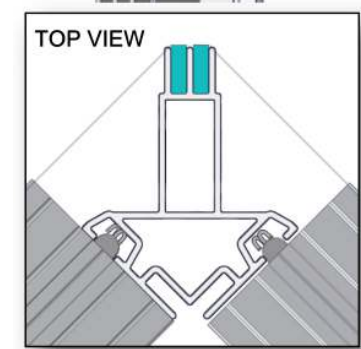
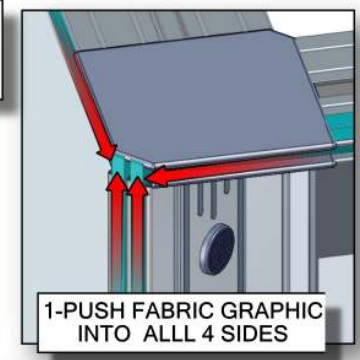
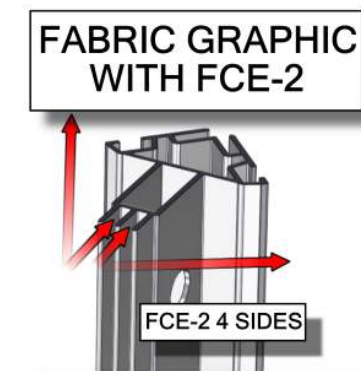
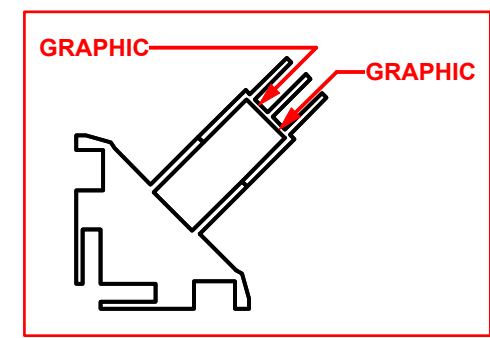
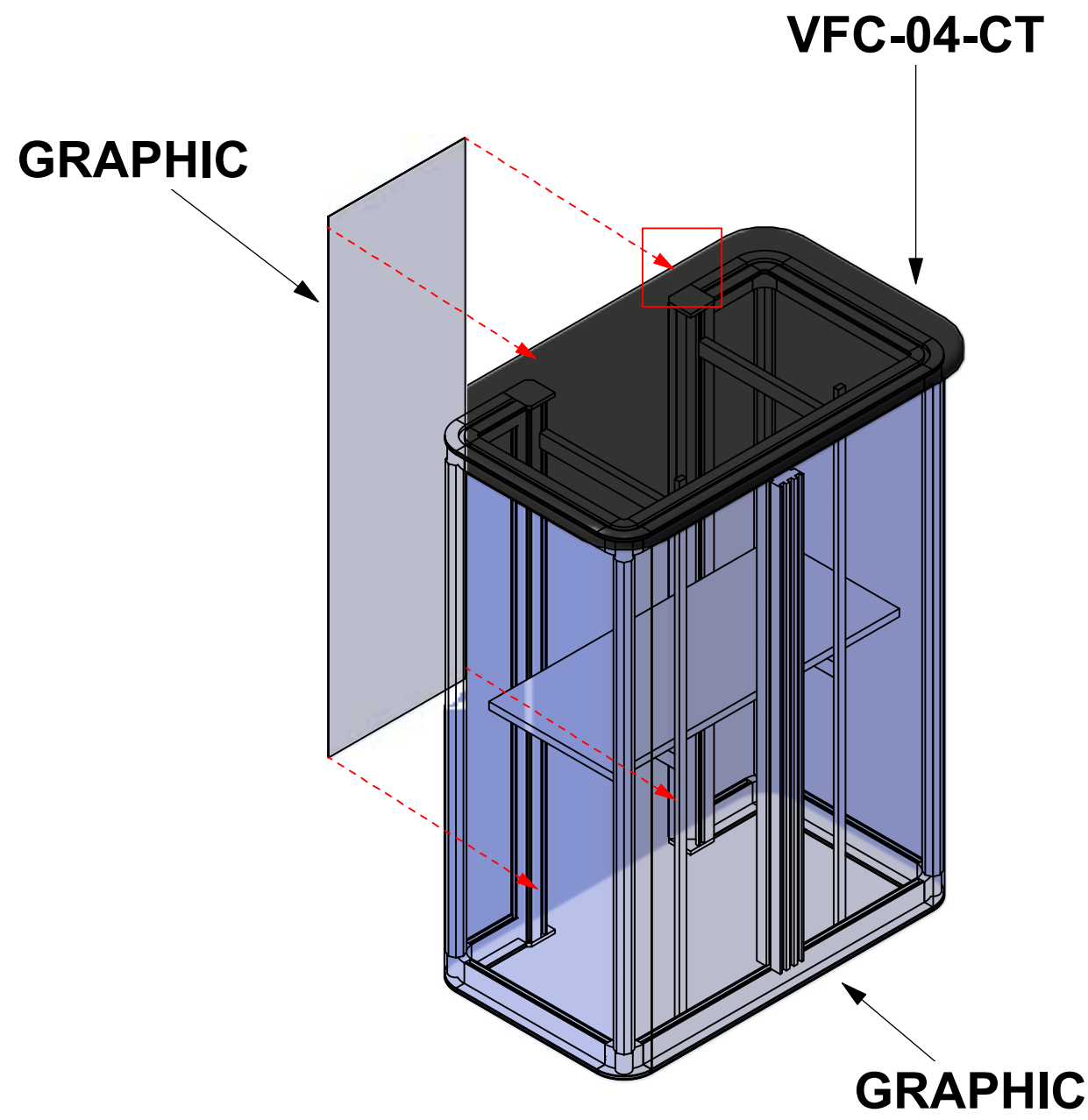
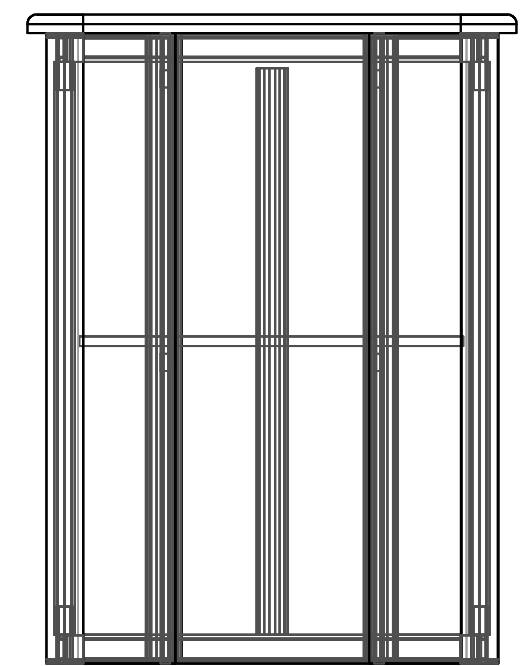
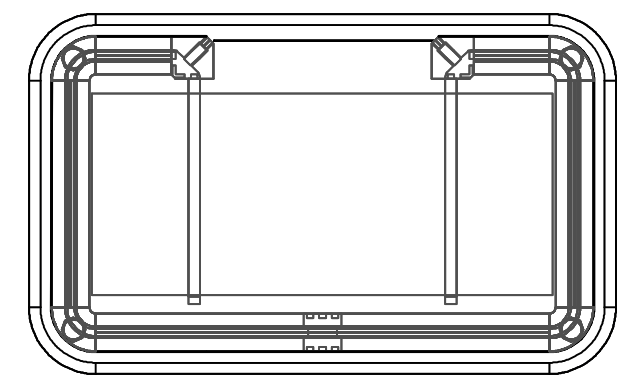
2400mm = (94 1/2")	Phone Line / Fax
2100mm = (82 5/8")	Internet connection
1800mm = (70 7/8")	Outlet
1500mm = (59")	Main Drop (point of distrution)
1200mm = (47 1/4")	
900mm = (35 1/2")	
600mm = (23 5/8")	
300mm = (11 7/8")	

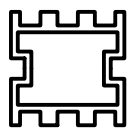
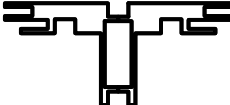
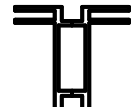
--- Wire running under carpet

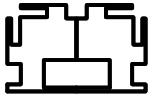
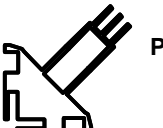

-  PM2S2
-  PHFC4
-  PHFC2
-  PH
-  PH4SC
-  PH1
-  PMFC2-T
-  PMFC2-90

HYBRID PRO RENTAL KIT

Title: SET-UP INSTRUCTIONS

PACKING INSTRUCTIONS



2



3

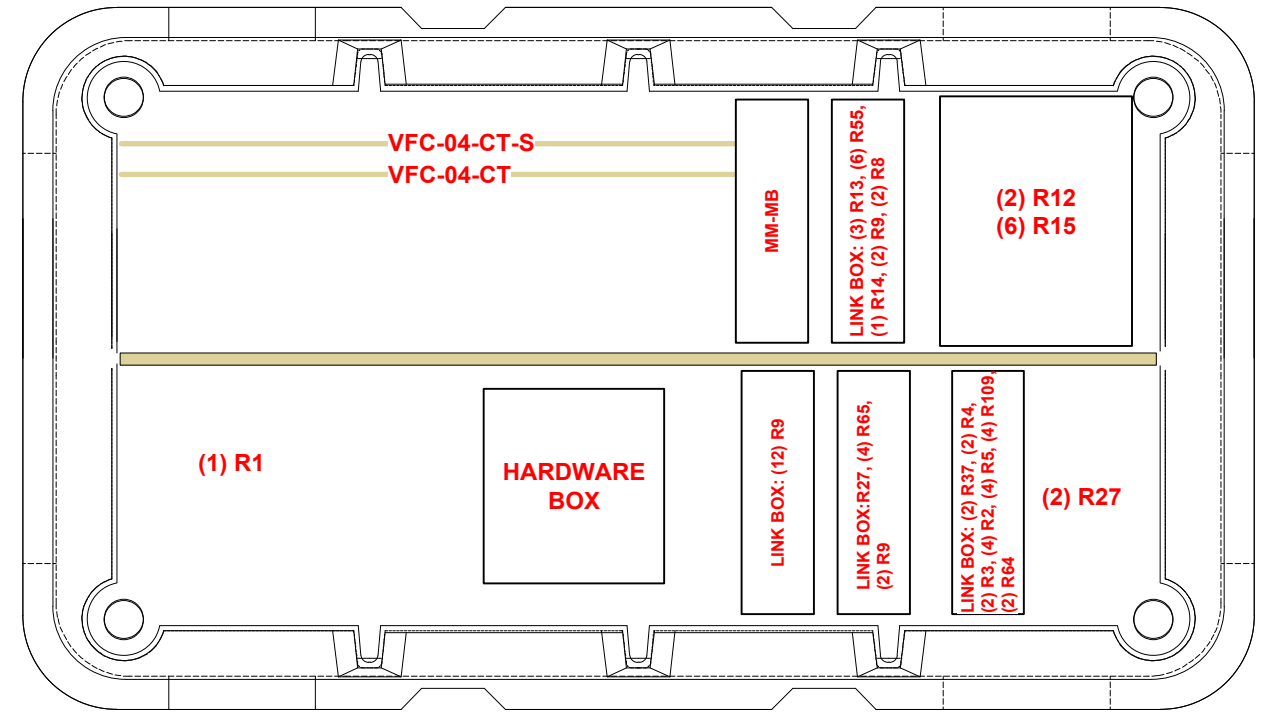

HARDWARE BOX



CASE # 1

LEGEND	
	GREY FOAM FOLDED TO FILL EMPTY SPACES OR USED AS PROTECTION
	1/8" CARDBOARD SPACER (PUT IN BETWEEN EVERY PANEL)
	DIVIDER
	1/4" WHITE FOAM (USED AS PROTECTION DOOR PANELS W/ LOCKS)





INTERNAL DIMS 49"L X 24.5"W X 51"H
EXTERNAL DIMS 59"L X 34"W X 57"H

SCRATE



TUBE STRUCTURE

CASE # 2

LEGEND		GREY FOAM FOLDED TO FILL EMPTY SPACES OR USED AS PROTECTION
		1/8" CARDBOARD SPACER (PUT IN BETWEEN EVERY PANEL)
		DIVIDER
		1/4" WHITE FOAM (USED AS PROTECTION DOOR PANELS W/ LOCKS)



Monitor Bracket Instructions

Extrusion Channel Applications

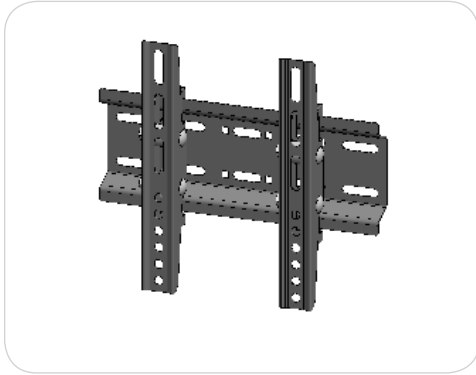

EXT-SM-MB

**Vesa Pattern: 75 x 75
up to 200 x 200mm**

Max weight varies per application

Assembled unit:

10" w x 8.86" h x 2" d
255mm (w) x 225mm (h) x 50mm (d)

Shipping dimensions:

14" l x 6" h x 4" d
356mm (l) x 152mm (h) x 102mm (d)

Approximate total shipping weight:

6 lbs / 3 kg

Recommended monitor sizes:

23" - 42"

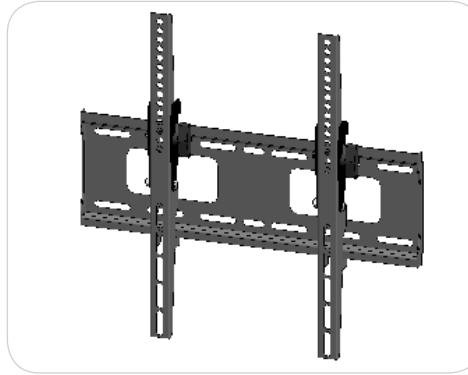

EXT-M-MB

**Vesa Pattern: 200 x 200
up to 400 x 400mm**

Max weight varies per application

Assembled unit:

17.6" w x 16.7" h x 1.6" d
448mm (w) x 425mm (h) x 40mm (d)

Shipping dimensions:

24" l x 4" h x 4" d
610mm (l) x 102mm (h) x 102mm (d)

Approximate total shipping weight:

8 lbs / 4 kg

Recommended monitor sizes:

32" - 55"

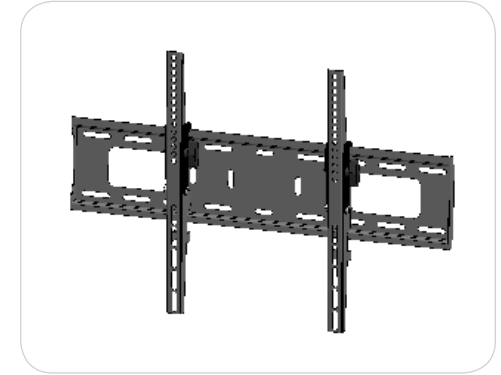

EXT-LG-MB

**Vesa Pattern: 200 x 200
up to 600 x 400mm**

Max weight varies per application

Assembled unit:

25.9" w x 16.7" h x 1.6" d
658mm (w) x 425mm (h) x 40mm (d)

Shipping dimensions:

28" l x 6" h x 6" d
711mm (l) x 152mm (h) x 152mm (d)

Approximate total shipping weight:

9 lbs / 5 kg

Recommended monitor sizes:

37" - 70"

Included hardware:

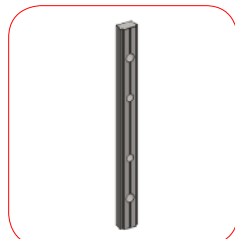

LN-100

x2



M5 x 10

LN-LCD-SCW

x2



1/4"-20 x 1"

BOLT-1

x2



1/4"-20

Flange Wing nut

x2

Extrusion Connection

Channel Connection A

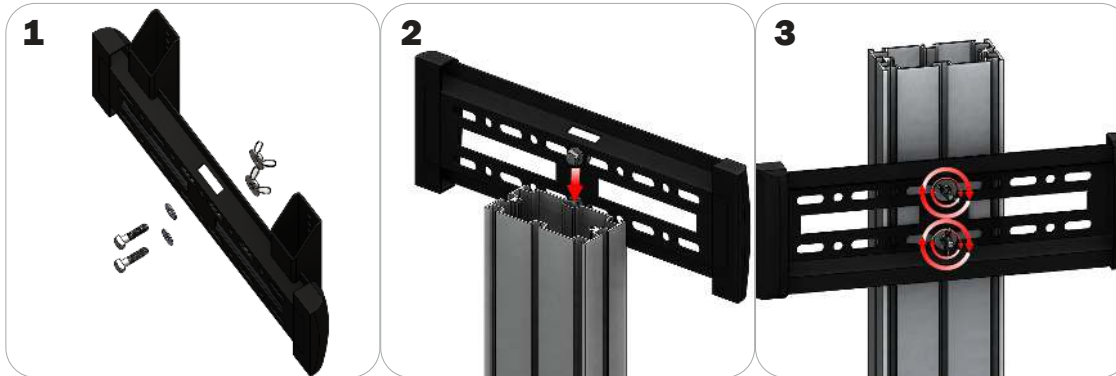

Locate all components needed to assemble the monitor mount with the channel connection A method. You will need (1) monitor bracket, (2) square head bolts, (2) washers, and (2) wing nuts.

Step 1: Insert the provided bolts through the washers and center top and bottom holes of the monitor mount. Loosely thread your wing nuts onto the end of the bolts.

Step 2: Slide the bolt heads down the extrusion channel.

Step 3: Tighten your wing nuts to lock the monitor bracket in place.

Step 4: Reference the included manufacturer monitor mount instructions for fastening your monitor to the bracket.

Channel Connection B

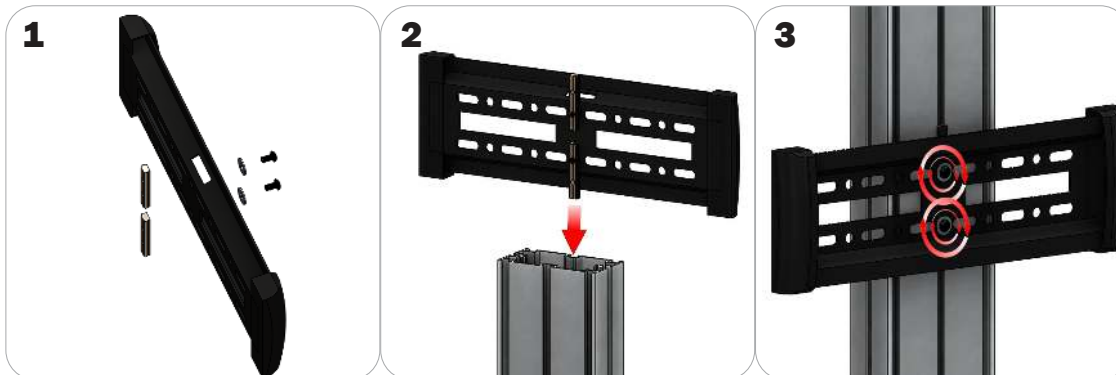

Locate all components needed to assemble the monitor mount with the channel connection B method. You will need (1) monitor bracket, (2) LN-LCD-SCW, (2) LN-100, and (2) washers.

Step 1: Loosely thread the LN-LCD-SCW screws through the washers, the center top and bottom holes of the monitor bracket, and through the LN-50 holes.

Step 2: Slide the LN-100s down the extrusion channel.

Step 3: Tighten your LN-LCD-SCW to lock the monitor bracket in place.

Step 4: Reference the included manufacturer monitor mount instructions for fastening your monitor to the bracket.

Extrusion Connection

TRI-30MM Channel Tube Connection

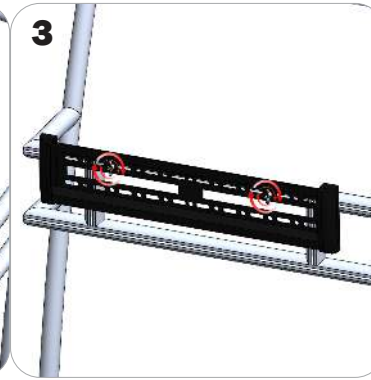
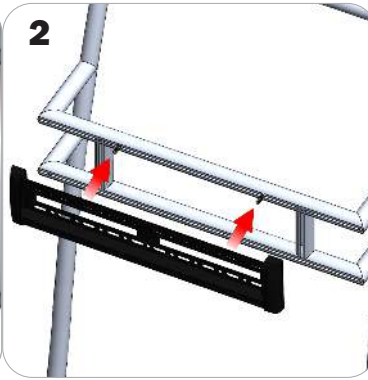
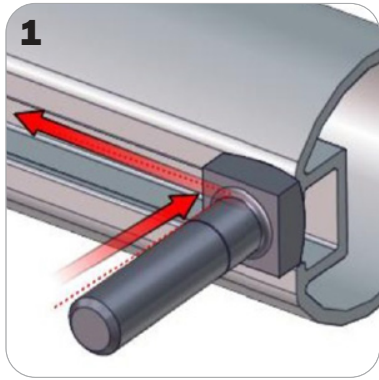

Locate all components needed to assemble the monitor mount with the TRI-30MM Channel Tube Connection method. You will need (1) monitor bracket, (2) Square Bolts, and (2) Wingnuts.

Step 1: Slip the head of the square bolts into the extrusion channel of the tube.

Step 2: Apply your monitor bracket to the protruding square bolts.

Step 3: Lock your monitor bracket to the square bolts using the provided wingnuts.

Step 4: Reference the included manufacturer monitor mount instructions for fastening your monitor to the bracket.