

Vector Frame Counter 05

VFC-05

Vector Frame™ counters compliment the Vector Frame series of exhibit kits, but are also ideal for any stand-alone event or display. Vector Frame counters couple simple extrusion-based frames with push-fit graphics or rigid sintra graphics. Tables are available in four colored finishes. Custom sizes also available.



features and benefits:

- Features rigid sintra graphics and simple extrusion based frames
- Locking door
- Choose from four tabletop finishes
- Easy step-by-step instructions
- Allow for extra storage by removing one fabric panel
- OCH2 portable shipping case
- Lifetime limited warranty against manufacturer defects

dimensions:

Hardware	Graphic
<p>Assembled unit: 39.76" w x 40.5" h x 22.75" d 1009.904mm(w) x 1029mm(h) x 578mm(d)</p>	<p>Total visual area: Front: 38" w x 19.5625" h 965mm(w) x 467mm(h)</p> <p>Sides (each): 9.81" w x 19.5625" h 249mm(w) x 467mm(h)</p> <p>Please be sure to include a 2" bleed around the perimeter</p>
<p>Shipping</p> <p>Shipping dimensions - ships in 1 case: OCH2 case: 52" l x 30" w x 15" h 1300mm(l) x 750mm(w) x 400mm(h)</p> <p>Approximate shipping weight (entire kit): 93.5 lbs / 42.41 kgs</p>	<p>Refer to related graphic template for more information</p> <p>Visit: www.exhibitors-handbook.com/graphic-templates</p>

additional information:

Graphic material:
rigid sintra graphics

Tabletop color options:



silver



black



mahogany



natural

Counter holds max weight
50 lbs / 22.7 kgs

We are continually improving and modifying our product range and reserve the right to vary the specifications without prior notice. All dimensions and weights quoted are approximate and we accept no responsibility for variance. E&OE. See Graphic Templates for graphic bleed specifications.

Parts Included:

Code	Qty	Description
VE-80	x2	RADIUS PH-2RN PH EXTRUSION WITH LOCKS BOTH ENDS (LOCKS IN)
VE-69	x4	1000MM (39.38") 50MM PM2R8 8 WAY ROUND EXTRUSION
VE-74	x4	250MM (9.84") PH EXTRUSION WITH LOCKS TWO ENDS
VE-84	x1	600MM (23.62") X 854MM (33.63") FRAME CABINET DOOR
CAM LOCK 2012	x4	LOCK (SHELF SUPPORT)
VFC-05-CT	x1	COUNTERTOP FOR VECTOR COUNTER VFC-05
VFC-05-S	x1	INTERNAL SHELF FOR VECTOR COUNTER VFC-05
VFC-05-B-G	x1	510MM (20.07")W X 262MM (10.31")H PVC GRAPHIC
VFC-05-A-G	x1	510MM (20.07") X 978MM (38.5") PVC GRAPHIC
VFC-05-C-G	x1	510MM (20.07")W X 262MM (10.31")H PVC GRAPHIC

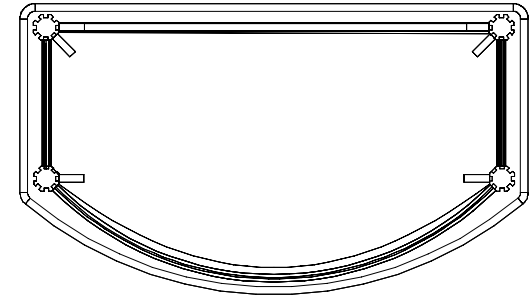

Overhead view



Assembled view

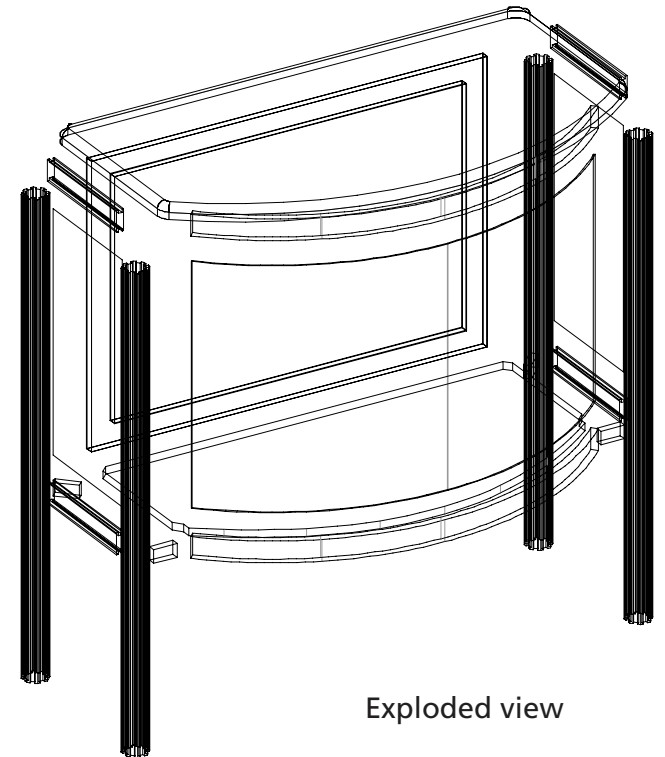

Exploded view

Step 1: Assemble Counter Frame & Install Rigid Graphics

Arrange pieces on the floor as shown in the diagram below. Assemble frame sides by securing VE-69 to VE-74 and VE-80. Then, slide in rigid graphic panels and secure on top with VE-74, VE-84 and VE-80. When locking be sure to turn each cam a little bit and then go back and tighten to the proper tension. Take care to turn locks only a quarter turn, so as to not strip the locks by over tightening.

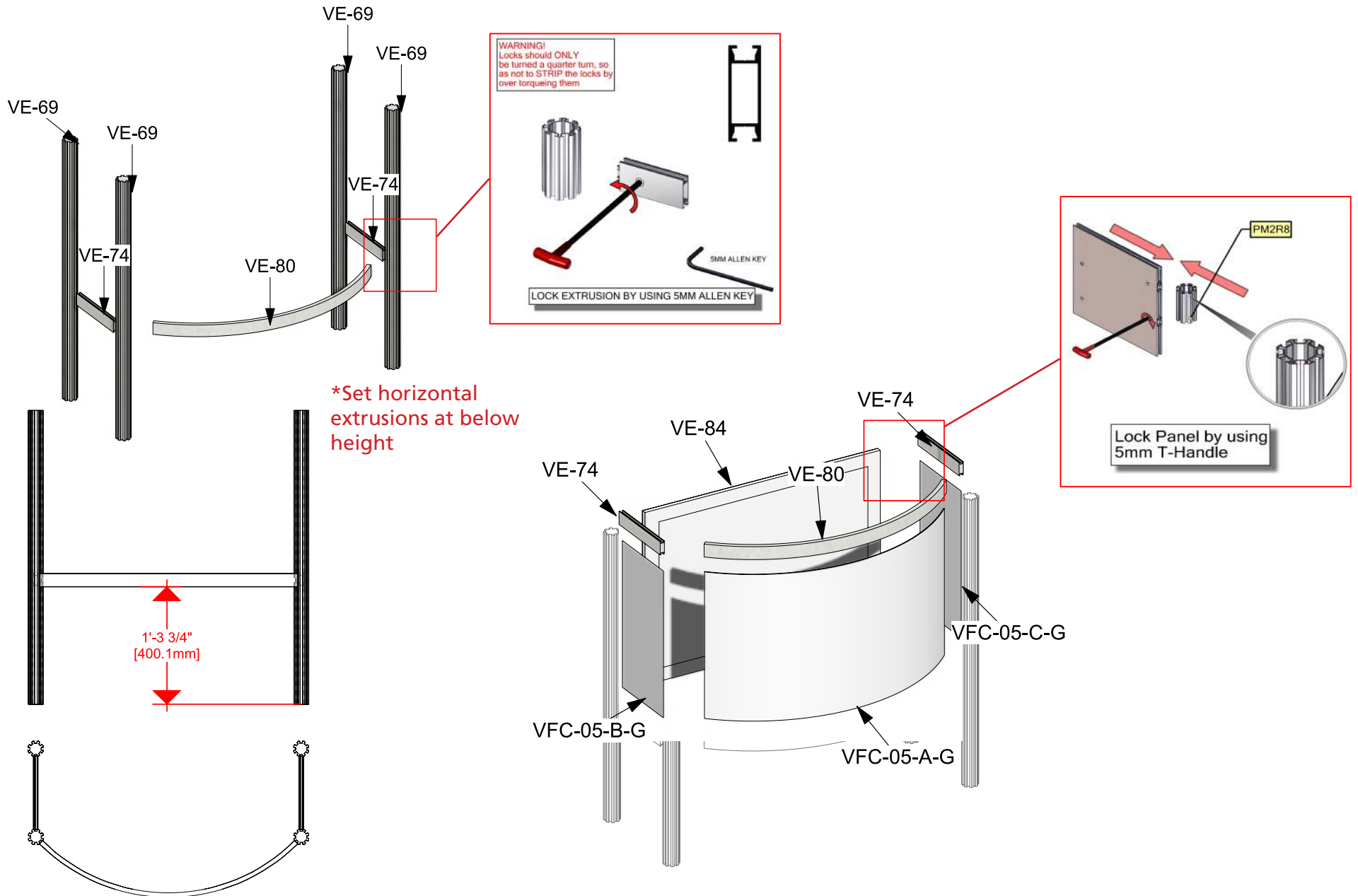

Step 2: Install Internal Shelf & Attach Countertop

To install internal shelf, secure CAM LOCK 2012 at same height on each extrusion and lock by using 5mm hex key. Lower the internal shelf onto the four shelf supports. Then gently lower the countertop onto the frame.

