

Vector Frame Counter 06

VFC-06





Vector Frame™ counters compliment the Vector Frame series of exhibit kits, but are also ideal for any stand-alone event or display. Vector Frame counters couple simple extrusion-based frames with push-fit graphics or rigid sintra graphics. Tables are available in four colored finishes. Custom sizes also available.



features and benefits:

- Features rigid sintra graphics and simple extrusion based frames
- Locking door
- Choose from four tabletop finishes
- Easy step-by-step instructions
- Allow for extra storage by removing one fabric panel
- OCH2 portable shipping case
- Lifetime limited warranty against manufacturer defects

dimensions:

Hardware	Graphic		
<p>Assembled unit: 41.7" w x 40.5" h x 20.75" d 1057mm(w) x 1029mm(h) x 527mm(d)</p> <p>Approximate weight with cases: 87 lbs / 39 kg</p>	<p>Refer to related graphic template for more information.</p> <p>Visit: www.exhibitors-handbook.com/graphic-templates</p>		
Shipping			
<p>Shipping dimensions - ships in 1 case:</p> <p>OCH2: 52" l x 30" w x 15" h 1300mm(l) x 750mm(w) x 400mm(h)</p> <p>Approximate shipping weight (entire kit): 89 lbs / 40.4 kg</p>			
additional information:			
<p>Counter holds max weight 50 lbs / 23 kg</p> <p>Internal Shelf holds 20 lbs / 9 kg</p>			
<p>Tabletop color options:</p>			
			
silver	black	mahogany	natural

We are continually improving and modifying our product range and reserve the right to vary the specifications without prior notice. All dimensions and weights quoted are approximate and we accept no responsibility for variance. E&OE. See Graphic Templates for graphic bleed specifications.

Included In Your Kit

Tools, Components, & Connectors



ALLEN KEY SET x1



PH-2R-L-L-IN x2



PH-300-S-S x4



PM2R8-1000 x4



VFC-06-CT x1

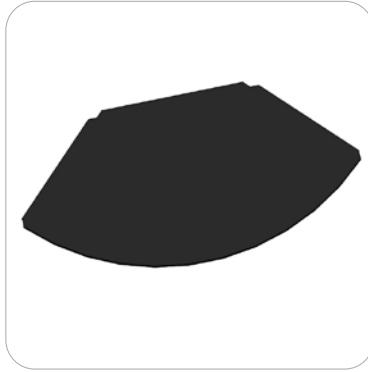

VFC-06-S x1



CAM LOCK x4



VFC-06-DR x1



PH-415-L x4



LN605-EN x4

Graphics

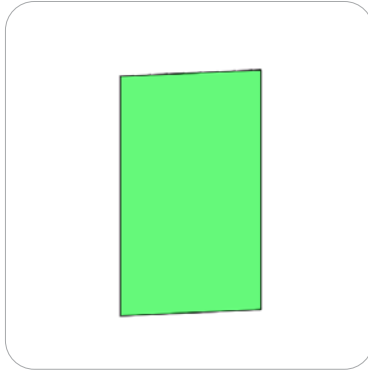

VFC-06-A-G x1

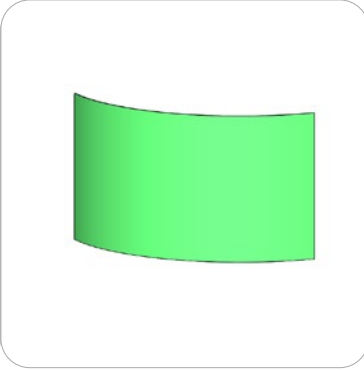

VFC-06-B-G x1

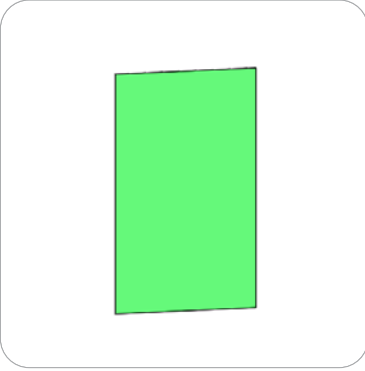

VFC-06-C-G x1

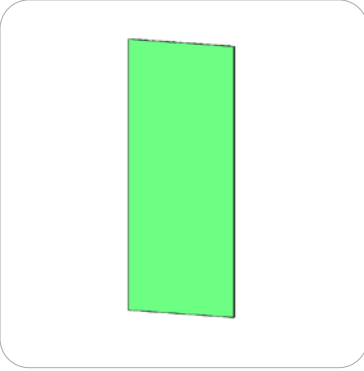

VFC-06-D-G x1



PM2R8-MCAP x4

Exploded View

VFC-06

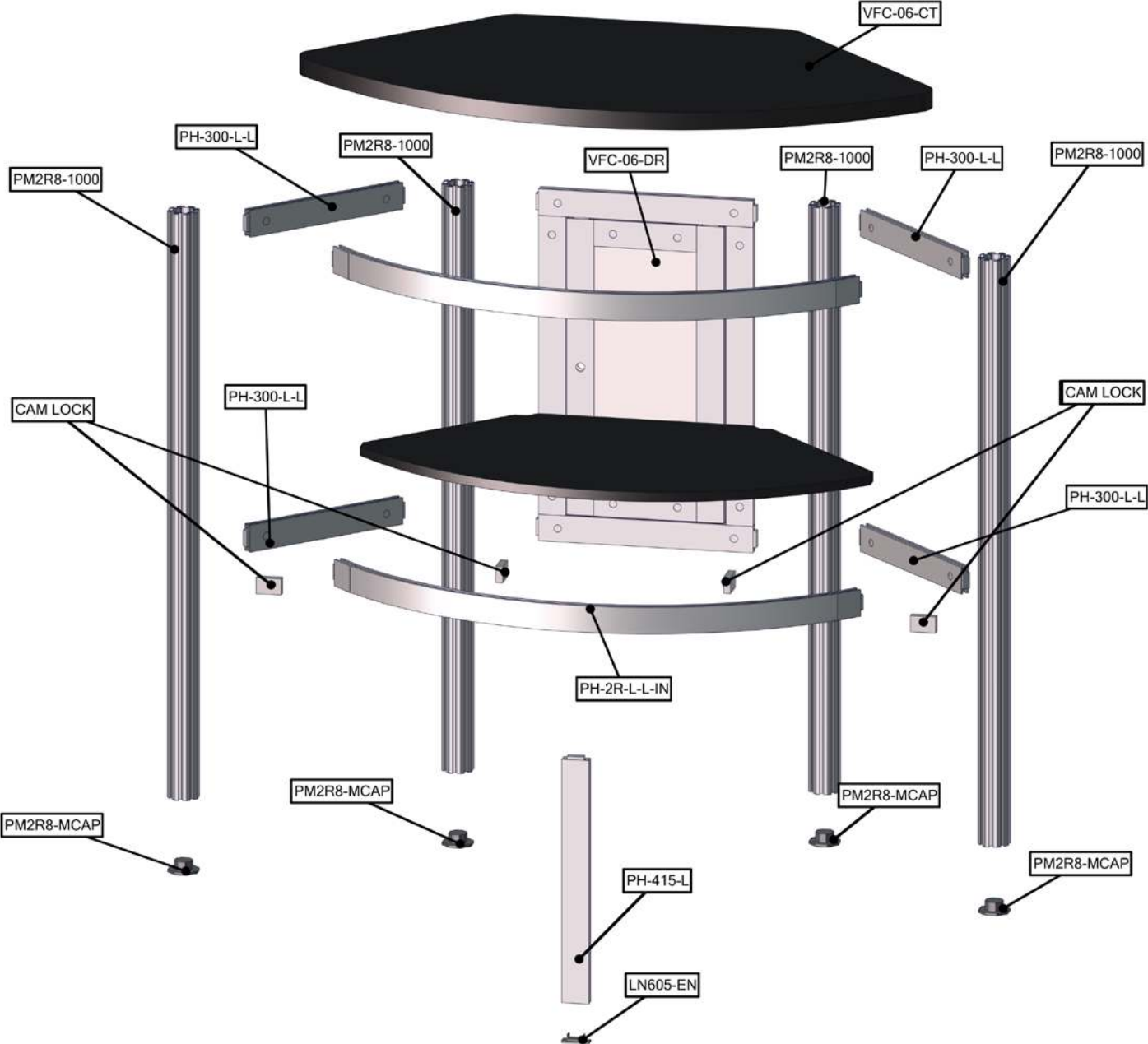

Connection Methods

Extrusion based structures use a number of different yet simple connection methods. Your kit will include one or more of the connection methods shown below. Steps within the Kit Assembly will reference a specific method for each connection point.

Connection Method 1: Cam Lock / Slide Lock

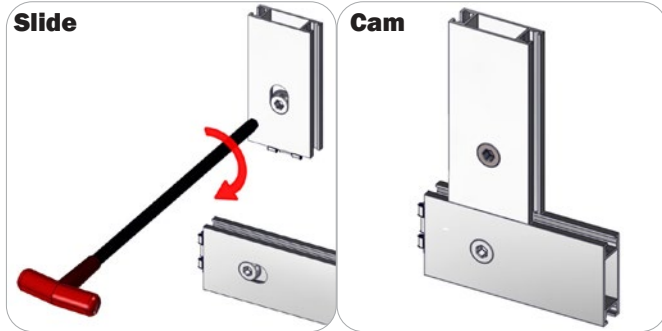

A cam lock equipped extrusion can lock to any cam lock channel. With the cam lock unlocked, set the teeth of the cam lock into the desired position on the cam lock channel. Using your allen key tool, carefully turn the lock clockwise to lock in place. Be sure to lock securely, but do not overtighten.

A slide lock equipped extrusion can also lock into any cam lock channel. When the slide lock is unlocked, pull back on the hex bolt head to retract the slide lock into the body of the extrusion. Slide locking procedure is the same as a cam lock.

Connection Method 2: IB2 / Corner Brackets

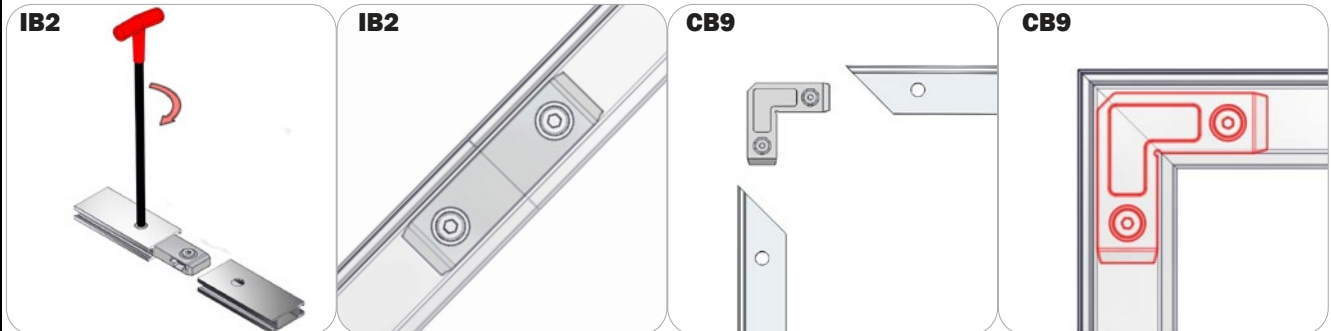

Press the hex bolt head in with your thumb and slide the extrusion and connector together so that the hex bolt head sits into the lock hole. Repeat with the second extrusion to the free end of the connector. Lock the extrusions together by turning carefully with the allen key tool. Be sure to lock securely, but do not overtighten.

Connection Method 3: SW-FOOT

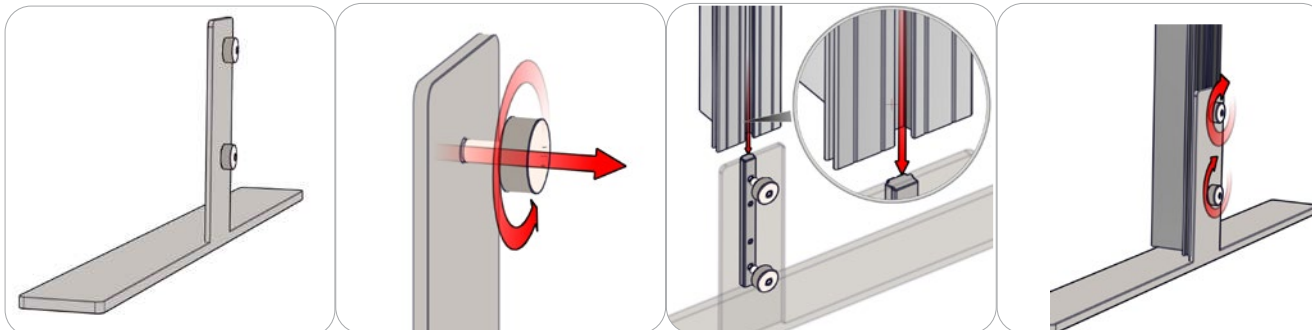

An SW-FOOT assembly consists of two thumb screws, an LN100, and SW-FOOT baseplate. Start by loosening the thumb screws (it is best not to completely remove the screws). Slide the extrusion onto the LN100 by utilizing its back cam channel. When the extrusion rests on baseplate or ground (depending on application), tighten the thumb screws to lock in place. Do not overtighten.

Kit Assembly

Step by Step

Step 1.

Gather (2) PM2R8-100 extrusions and (1) PH-2R-L-L-IN. Lock together so that the top of the PH-2R-L-L-IN is flush with the top of the PM2R8-100s.

Please reference Connection Method 1 for more details.



Step 2.

Locate (2) PM2R8-100 and (1) VFC-06-DR. Lock the door to the PM2R8-100s so that the top of the door assembly is flush with the top of your PM2R8-100s.

Please reference Connection Method 1 for more details.

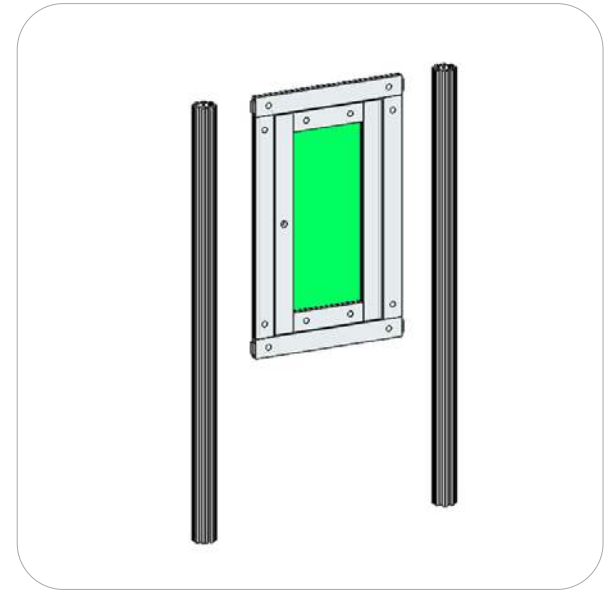
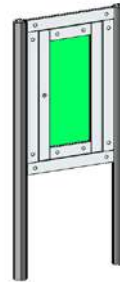

Step 3.

Combine Step 1 and Step 2 assemblies by adding (2) PH-300-S-S. Remember to lock the extrusions with the lock holes facing into the cabinet.

Please reference Connection Method 1 for more details.



Step 4.

Locate (4) CAM LOCKS. Lock each CAM LOCK into the corners of your VFC-06 assembly. Measure so that the bottom of the CAM LOCKS are flush to the bottom of the door assembly.

Please reference Connection Method 1 for more details.



Kit Assembly

Step by Step

Step 5.

Apply your VFC-06-S internal shelf. Allow the shelf to rest on the installed CAM LOCKS.



Step 6.

Slide your graphics up the sides of the cabinet until they rest against the top extrusions.

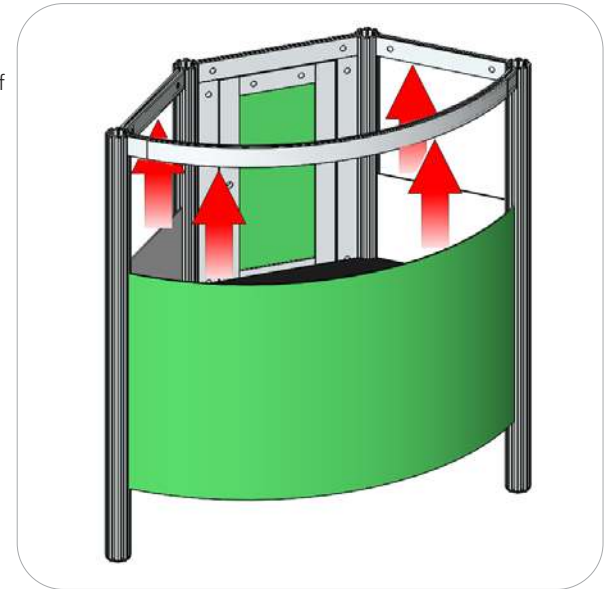
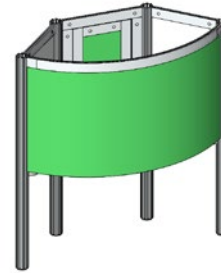

Step 7.

Add your second layer of extrusions to the bottom of the cabinet. You will need (2) PH-300-S-S, (1) PH-2R-L-L-IN, and (1) PH-415-L. Lock the PH-415-L to the center of the PH-2R-L-L-IN in its downward facing channel to create a 5th leg.

Please reference Connection Method 1 for more details.

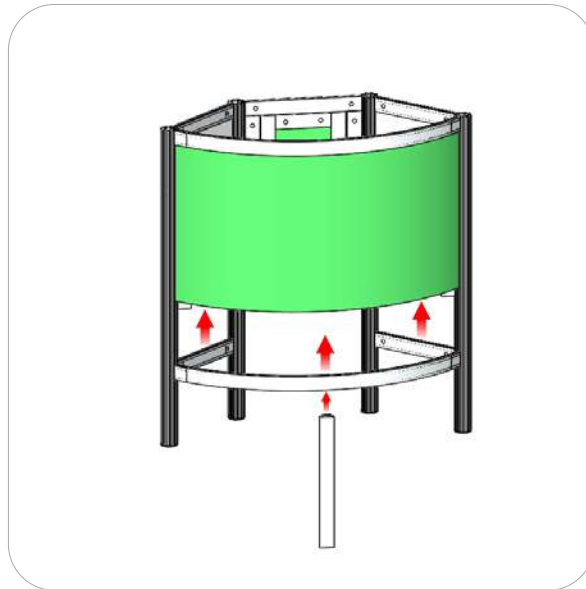
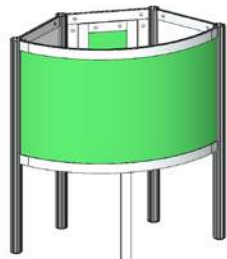

Step 8.

Place your VFC-06-CT on top of your unit. Add the remaining plastic caps to the bottom of each extrusion touching the ground.

Setup Complete.

