

# Formulate Essential Backlit Banner

## FMLT-ESS-BL-1100

The Formulate® Backlit Banner 1100 is a captivating and eye-catching banner that combines an aluminum tube frame with LED strip lights and a zipper pillowcase printed fabric graphic. The LED strip light helps draw attention to the display and offers even and bright white light balance throughout. The kit comes with hardware to be used at 2 different heights; 78.75" or 93.5"h. This tool-less kit features a weighted tubed base for added strength and stability. Quick, easy assembly and take down that stores in a zippered carry bag making you ready for the next show!



Without Extension:  
78.75" Height



With Extension:  
93.5" Height

## features and benefits:

- State of the art 30 mm aluminum tube frame with push-button connection
- LED light strips at the top and bottom of the frame
- Pillowcase fabric graphic is printed on backlit textile
- Frame height is configurable between 2 different heights
- Tool-less assembly
- Weighted bottom tubes
- 2 graphic options available; short or tall
- Kit includes: one frame, one dye-sublimated pillowcase graphic, lights and a carry bag
- 1-Year hardware warranty against manufacturer defects

## dimensions:

Hardware	Graphic
<p>Assembled unit: 43.25" w x 78.75-93.5" h x 12.5" d 1099mm(w) x 2001-2375mm(h) x 318mm(d)</p> <p>Approximate weight: 20 lbs / 9 kg</p>	<p>Refer to related graphic template for more information.</p> <p>One year warranty.</p> <p>Visit: <a href="https://www.theexhibitorshandbook.com/download-graphic-templates">https://www.theexhibitorshandbook.com/download-graphic-templates</a></p>

Shipping	additional information:
----------	-------------------------

<p>Packing case(s): 1 Box</p> <p>Shipping dimensions: 46" l X 15" h X 6" d 1169mm(l) x 381mm(h) x 153mm(d)</p> <p>Approximate total shipping weight: 22 lbs / 10 kg</p>	<p>Graphic material: Dye-sublimation pillowcase fabric - Backlit textile</p> <p>When included in a larger kit, a different packaging solution will be listed to accommodate all contents of the kit. Individual packaging no longer provided.</p>
---	---



This product may include the following materials for recycle:  
aluminum, select wood, fabric, cardboard, paper, steel, and plastics.

We are continually improving and modifying our product range and reserve the right to vary the specifications without prior notice. All dimensions and weights quoted are approximate and we accept no responsibility for variance. E&OE. See Graphic Templates for graphic bleed specifications.

\*Not to scale

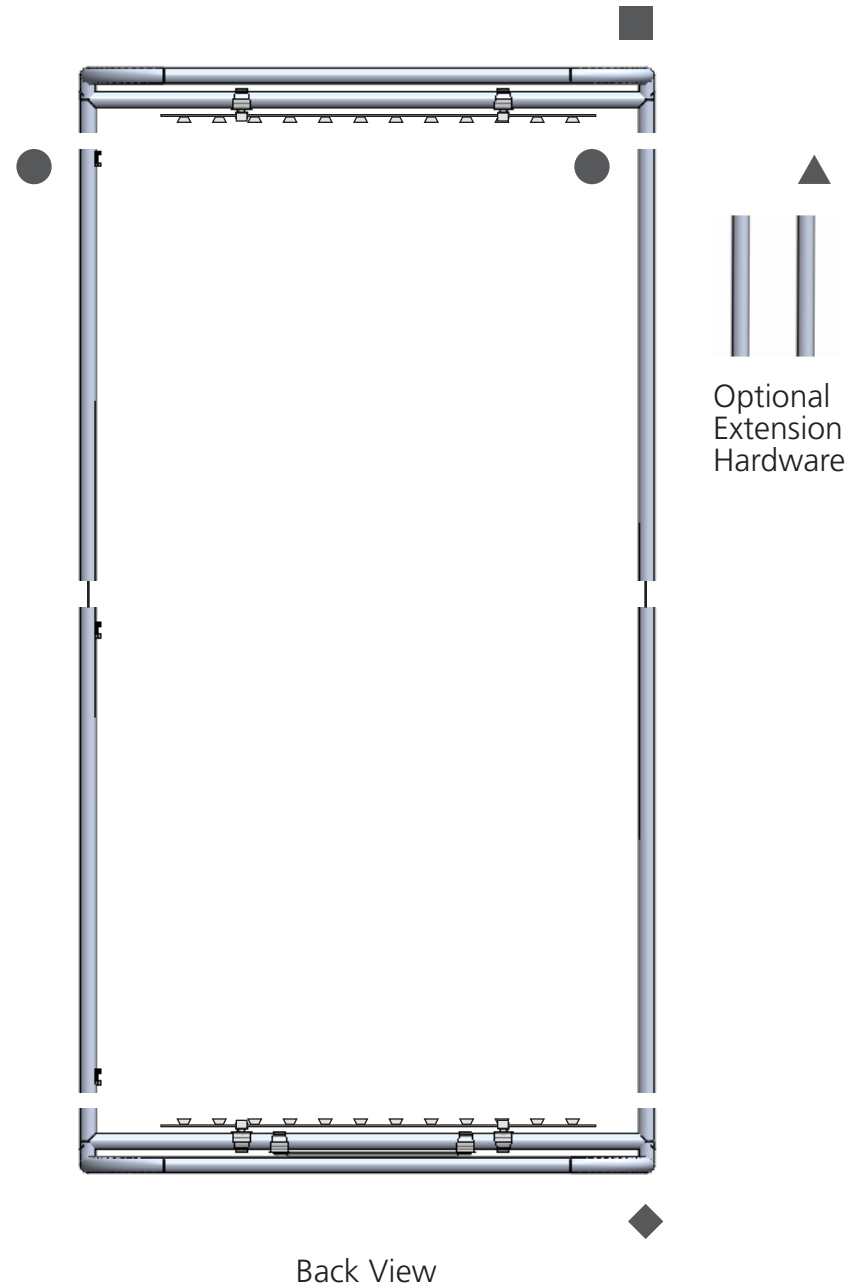
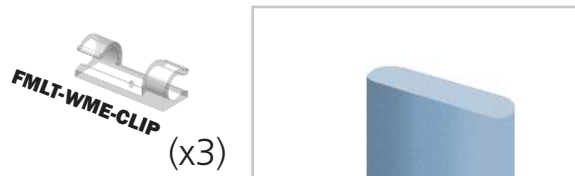
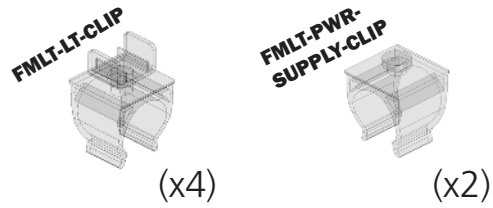
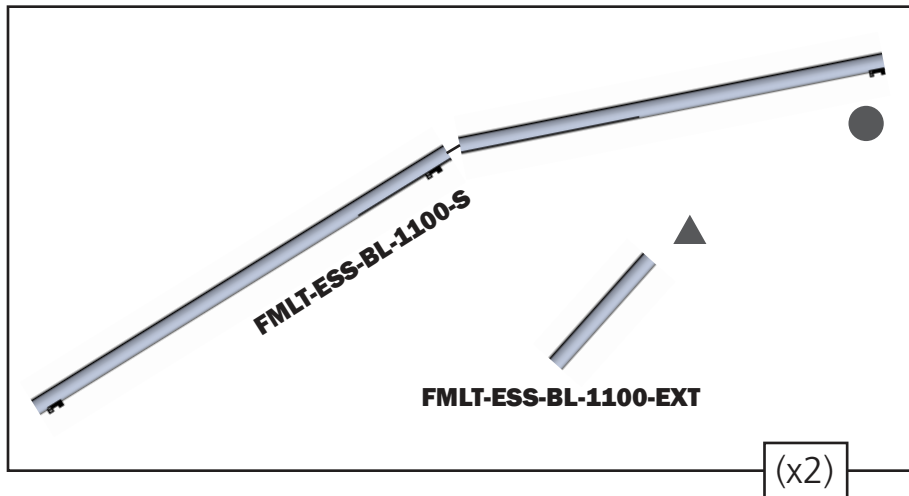



Light Attachment

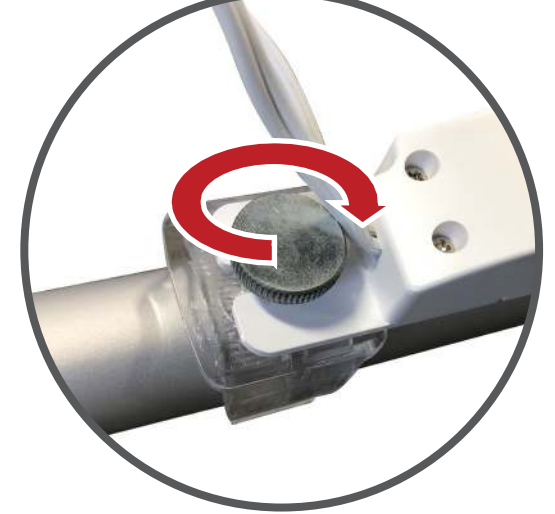
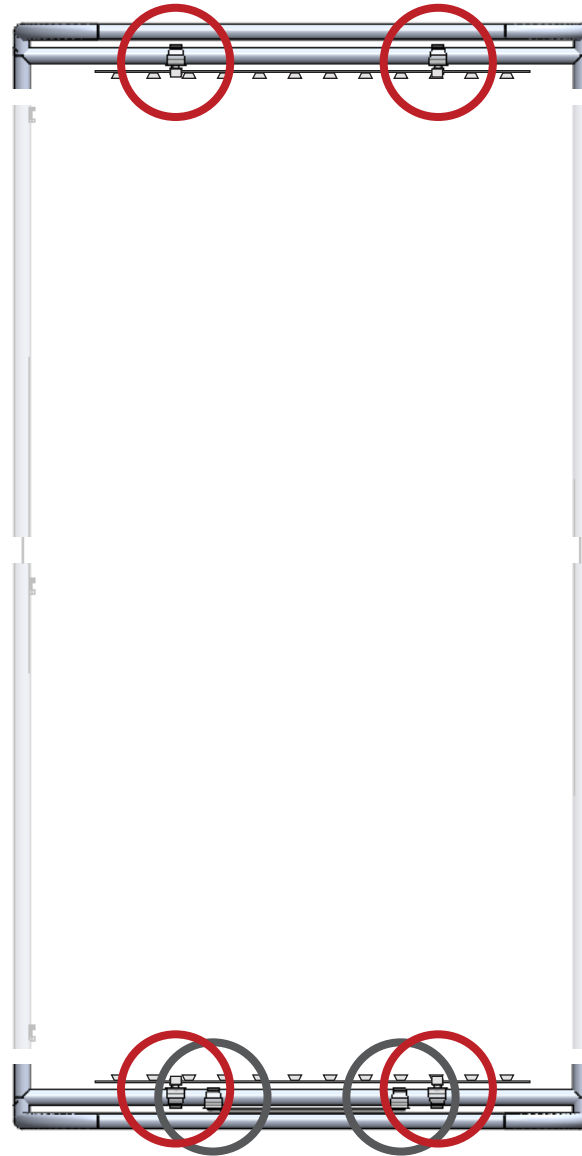

Power Supply Attachment

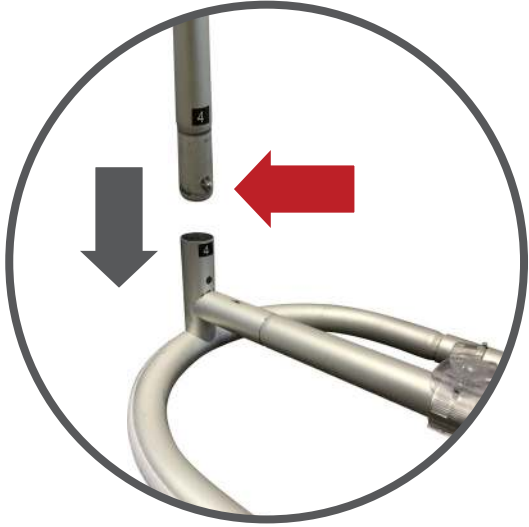
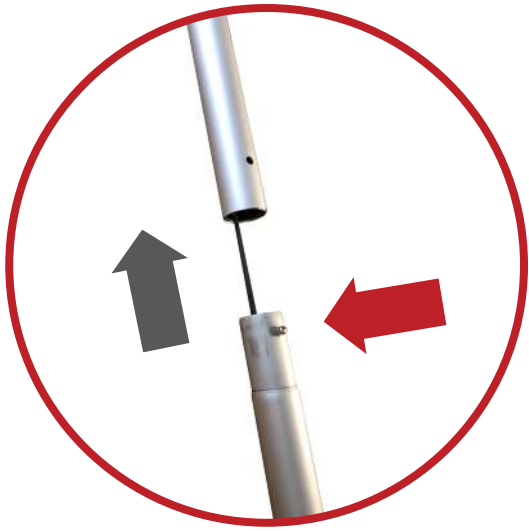

Hardware Connection

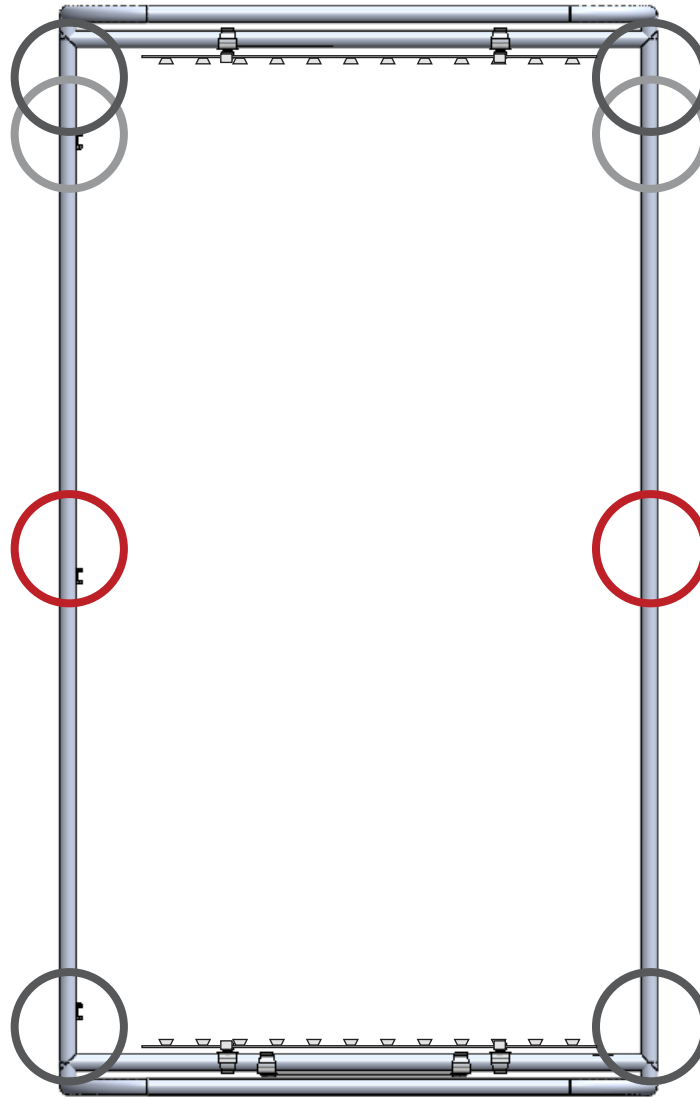

\*Extension tubes to be used to achieve max height of 93.5"

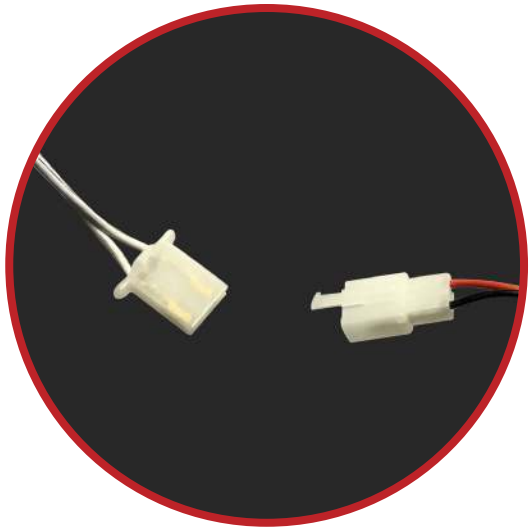

Light Connection

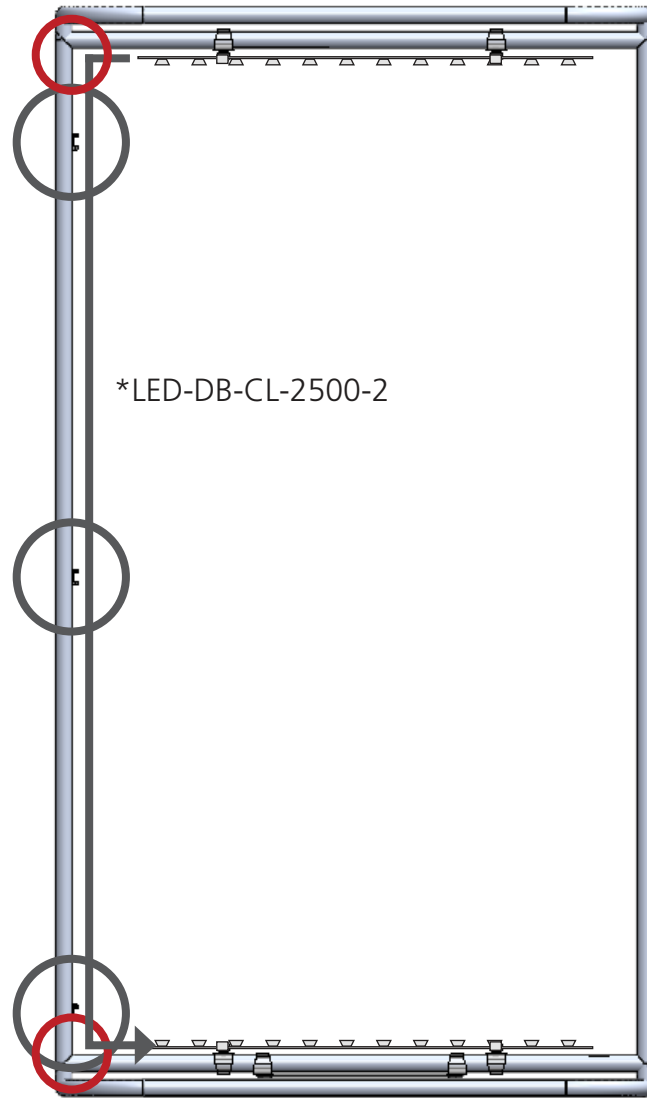

\*LED-DB-CL-2500-2



Wire Management

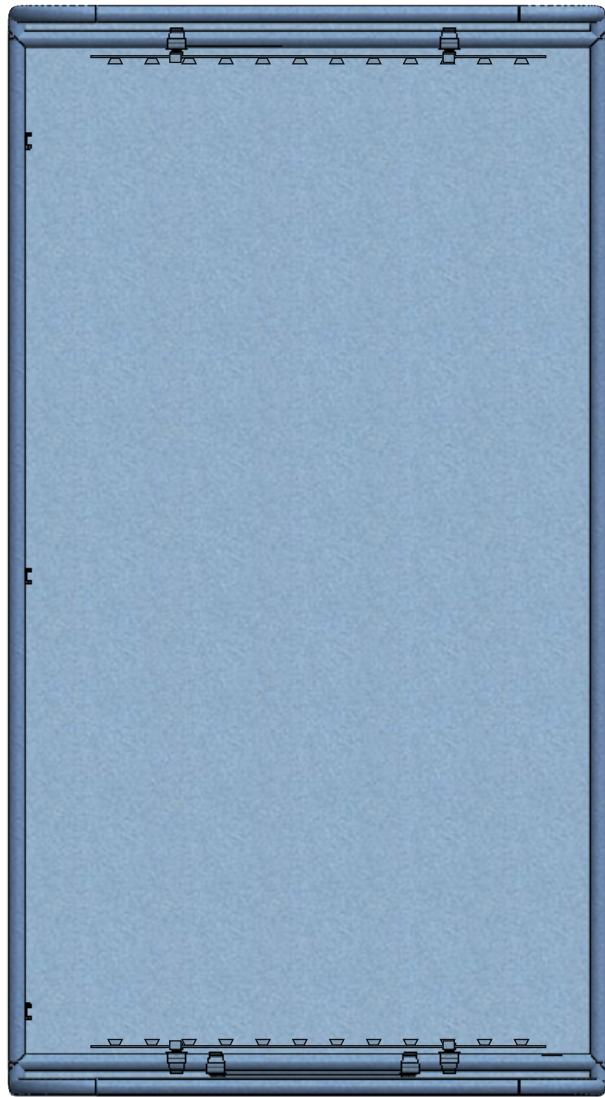

**Graphic**

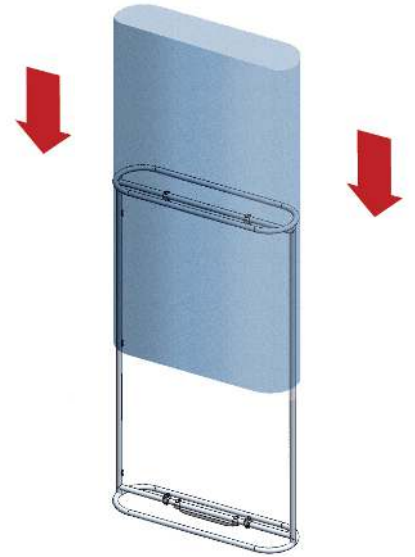

Hook and Loop Connection

