

Vector Frame Backlit Modular Tower 04 4'X10'

VF-BL-TOWER-04 VF-BL-TOWER-04-MM

The Vector Frame™ Backlit Tower 04 is an illuminated rectangular architectural structure that measures 10'h and 4' square at the top and bottom. The Backlit Tower 04 couples extrusion frames with interchangeable, vibrant push-fit fabric graphics and an internal lighting kit to create a dramatic and impressive accent or focal point. Add an optional monitor mount for additional branding and digital messaging opportunities. Each kit comes with a molded, wheeled case for easy storage and transportation.

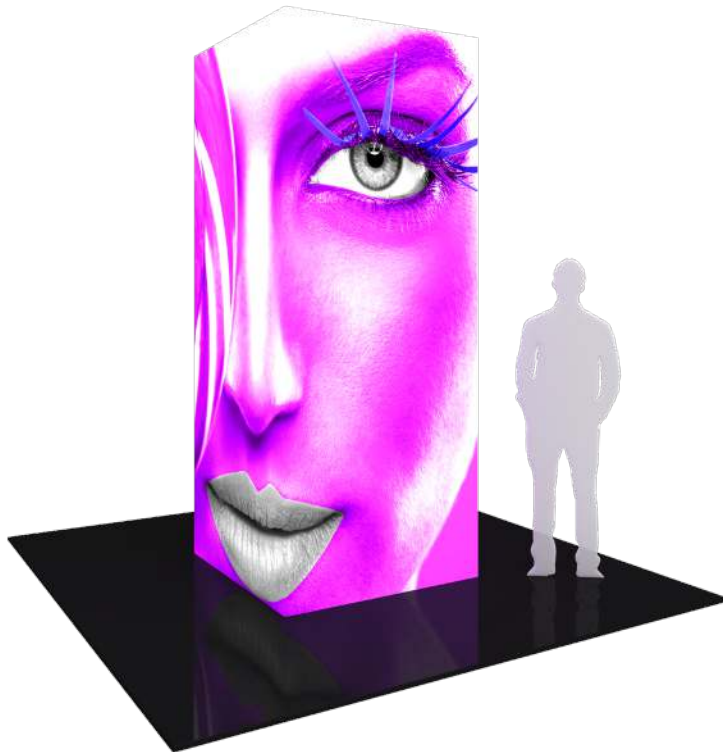

features and benefits:

- 50mm silver extrusion frames
- Internal LED lighting
- Interchangeable pushfit SEG fabric graphics for all 4 sides
- Monitor Mount option available

- Kit includes: one frame, 4 SEG backlit intensity push fit fabric graphics panels, 1 opaque liner panel, and one wheeled storage case
- Lifetime hardware warranty against manufacturer defects

dimensions:

Hardware

Graphic

Assembled unit:
47.97" w x 120.02" h x 47.97" d
1219mm(w) x 3049mm(h) x 1219mm(d)

Approximate weight with case:
89 lbs / 41 kgs

Refer to related graphic template for more information.

One year warranty

Visit:
<https://www.theexhibitorshandbook.com/download-graphic-templates>

Shipping

additional information:

Packing case(s):
1 OCE

Shipping dimensions:
OCE: Expandable case length (l) may vary

18" l x 40" - 66" h x 18" d
458mm(l) x 1016mm-1677mm(h) x 458mm(d)

Approximate total shipping weight
(includes cases & graphics):
100 lbs / 46 kgs

Graphic material:
Backlit Intensity push-fit fabric graphic and opaque liner
*This unit requires 6 light bulbs.

Lighting Power Requirements:

Total wattage needed:	Total ampage needed:	Voltage used:
144W	14A	110V

When included in a larger kit, a different packaging solution will be listed to accommodate all contents of the kit. Individual packaging no longer provided.

2 person assembly recommended:



This product may include the following materials for recycle:
aluminum, select wood, fabric, cardboard, paper, steel, and plastics.

We are continually improving and modifying our product range and reserve the right to vary the specifications without prior notice. All dimensions and weights quoted are approximate and we accept no responsibility for variance. E&OE. See Graphic Templates for graphic bleed specifications.

Included in your kit:

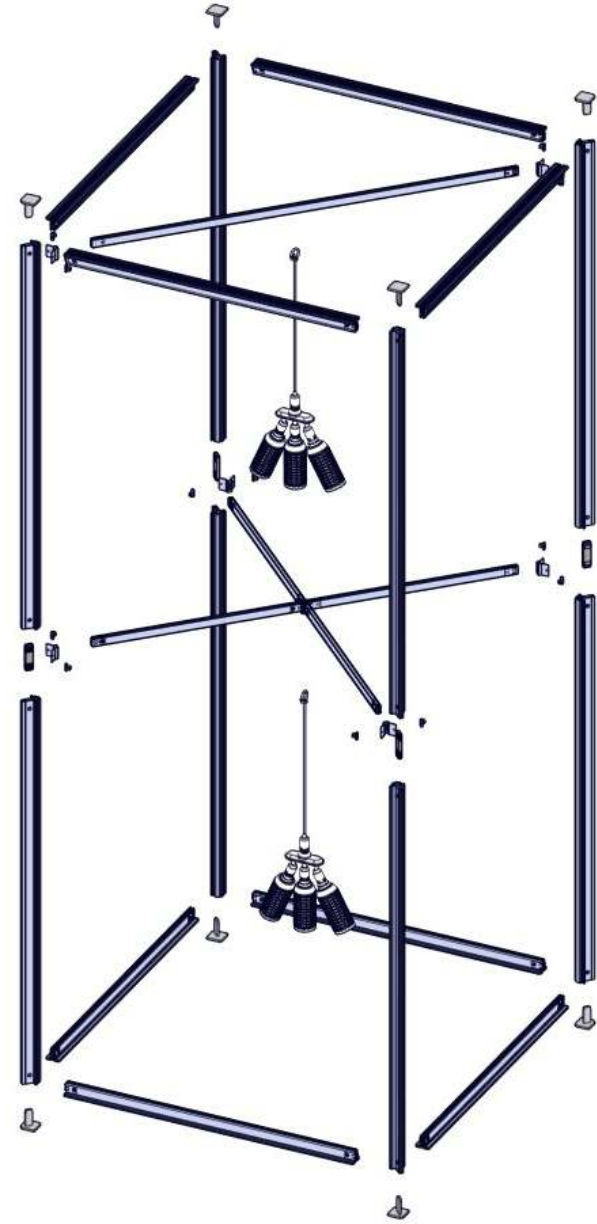
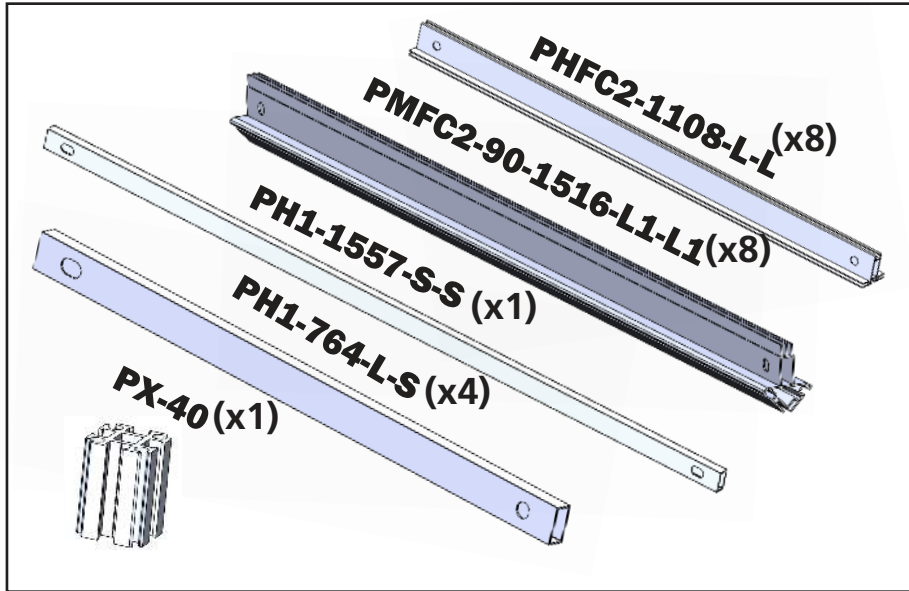

Tower Construction

For this step you will need:

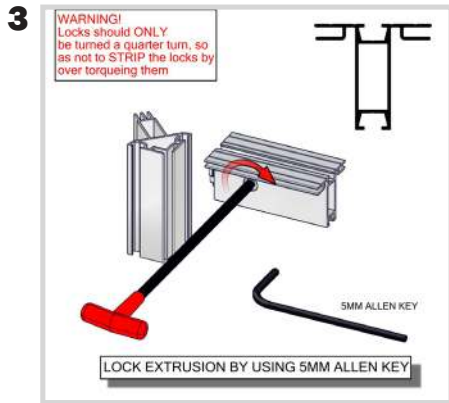
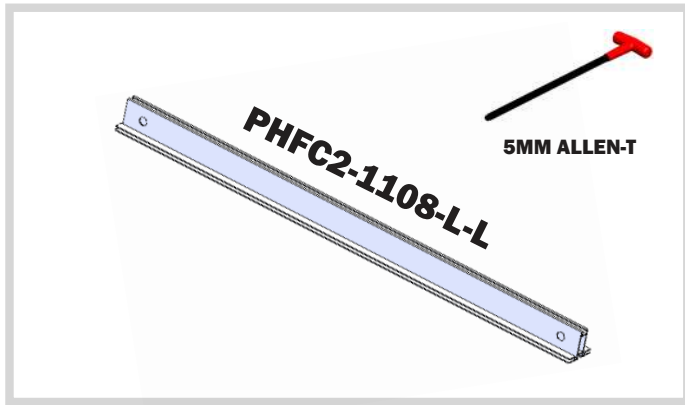

Using the 5mm Allen-T attach your PHFC2s to your PMFC2 verticals made in the previous step.

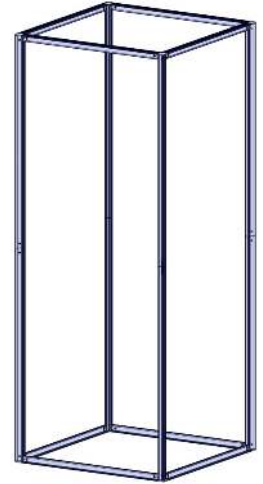
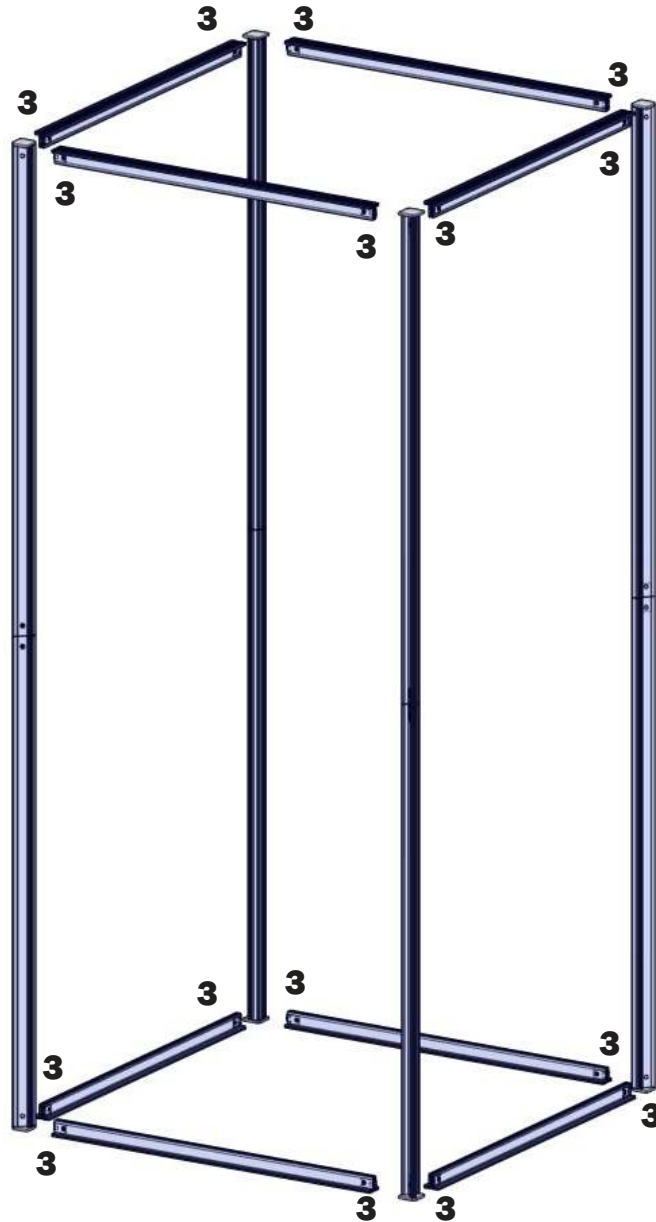

After this step you should have a rectangular tower.

Tower Construction

For this step you will need:

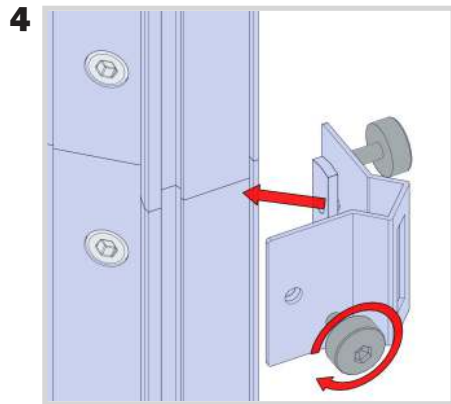

Using the screws provided, attach 8 of the brackets to the joints of your verticals and two at the top of you PMFC2 verticals.

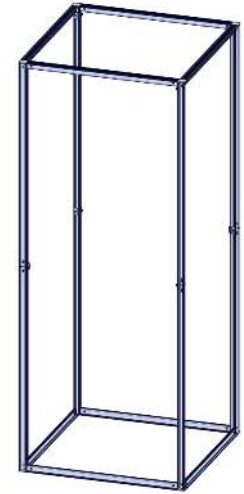
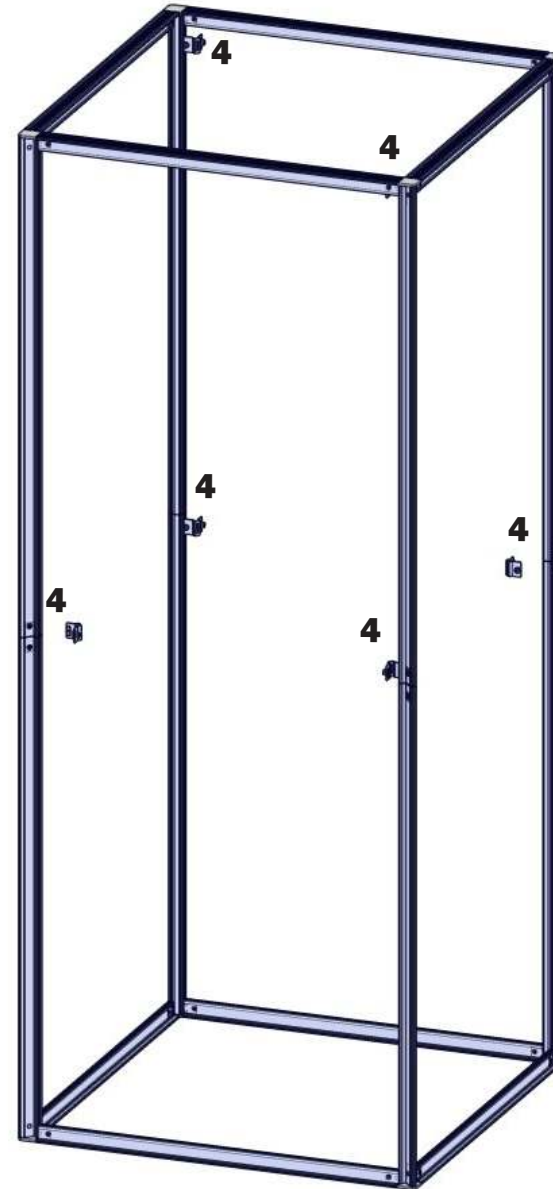

After this step you should have 6 brackets attached to your post.

Tower Construction

For this step you will need:

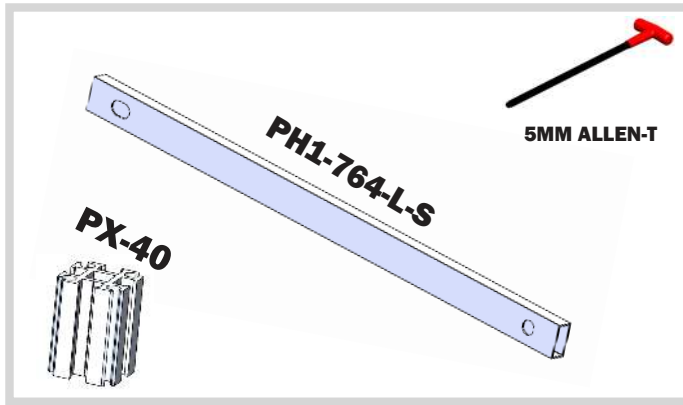

After this step you should have your cross support ready.

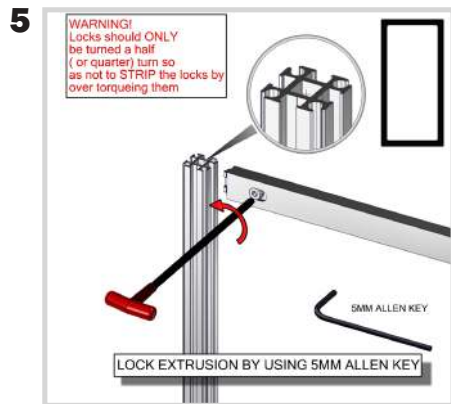

Using the 5mm Allen-T attach your supporting PH1 extrusions to the small PX extrusions.

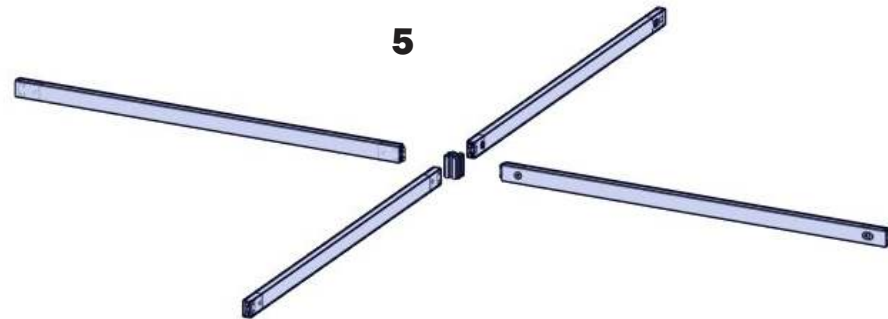

Tower Construction

For this step you will need:

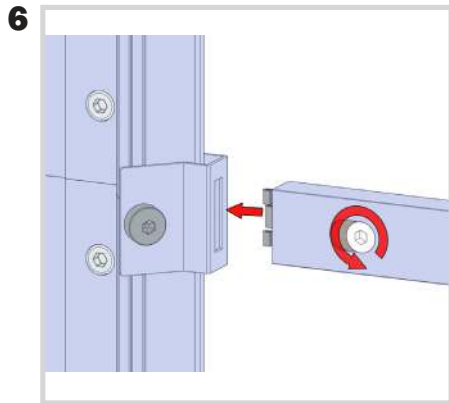
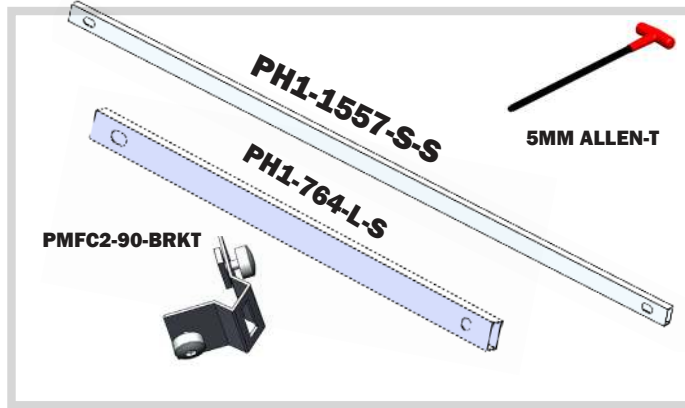

Using the 5mm Allen-T attach your supporting PH1 extrusions to your brackets.

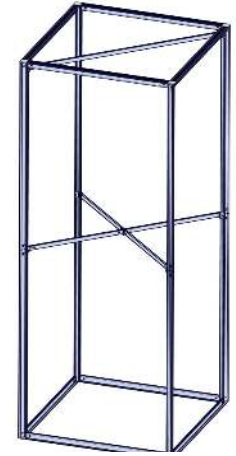
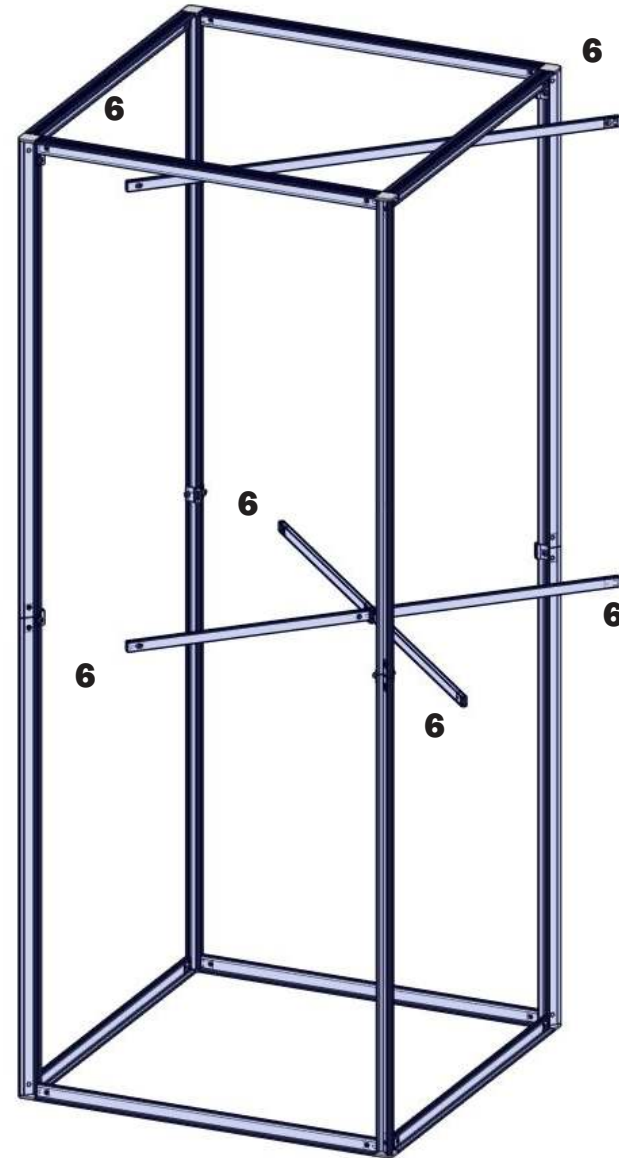

After this step you should have your supports connected to your tower.

Tower Construction

For this step you will need:

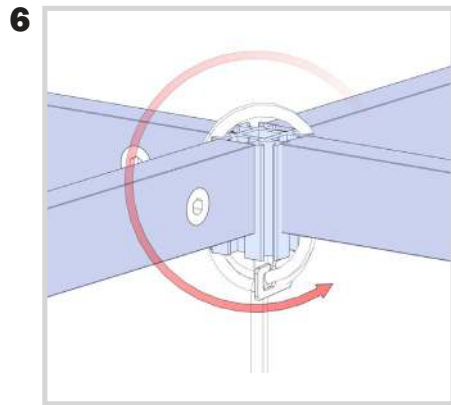

To attach lights to the tower simply wrap the cords around the joints in the middle of the frame.

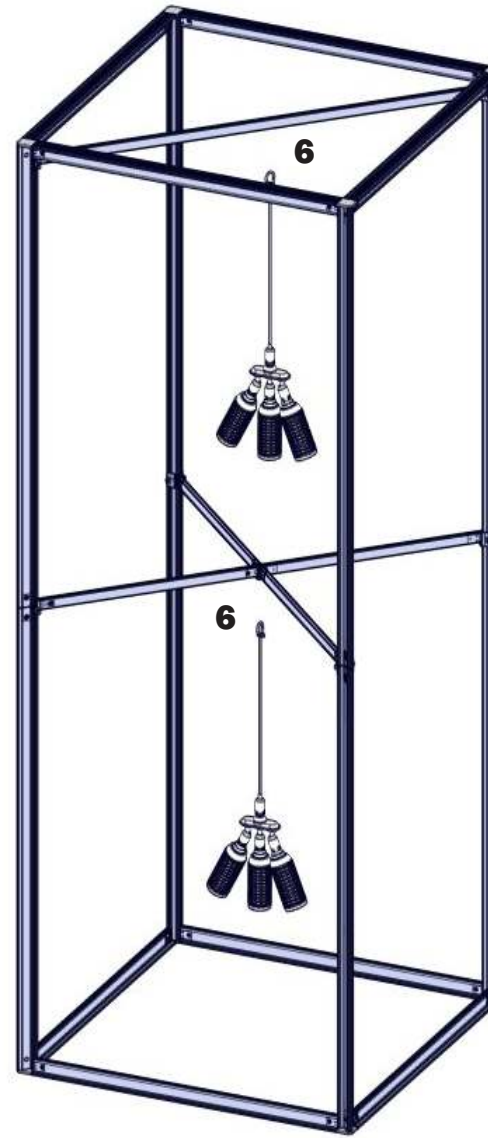

The lights are now attached to your tower.

Graphic Application

For this step you will need:

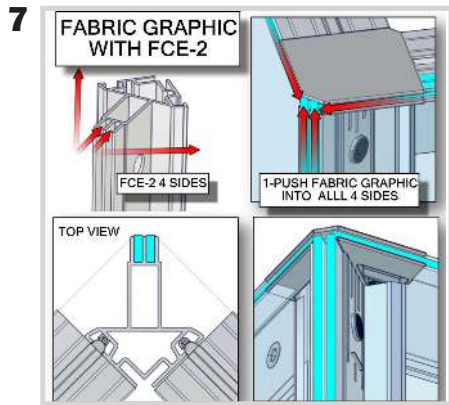
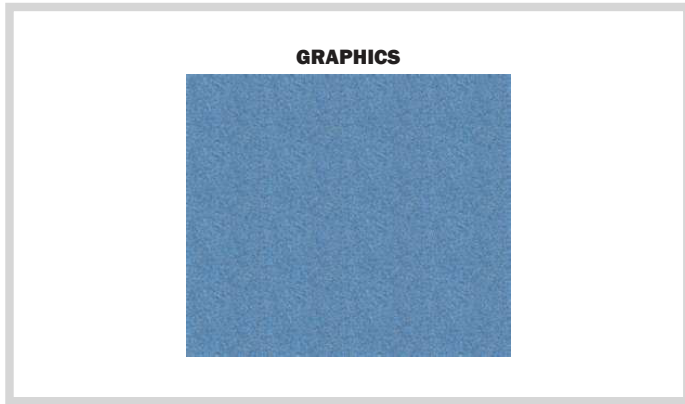

Insert your graphics into the FCE channels of your PMFC2 extrusions.

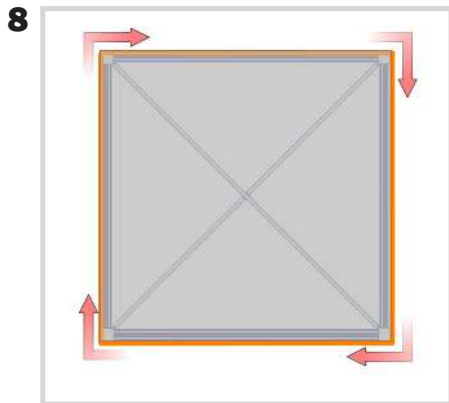

Your opaque liner will attach to the top of your tower with hook and loop fastener on the liner and on the top of the extrusion.

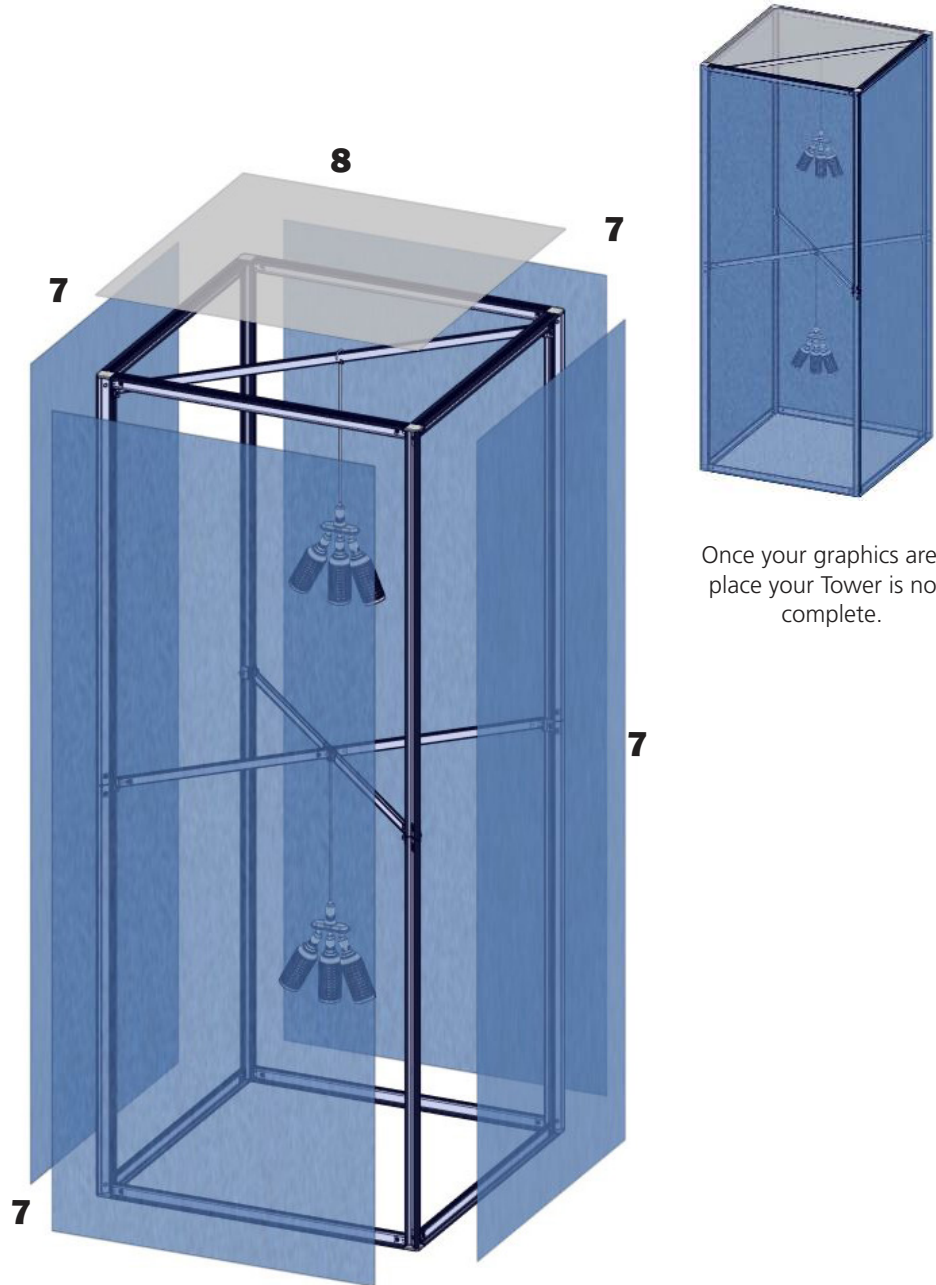

Once your graphics are in place your Tower is now complete.

Vector Frame Tower 4ft Monitor Mount

VF-TOWER-4FT-MM

Dual monitor mount attachments for 4 foot width Tower kits.

features and benefits:

-Kit includes: 2 medium monitor mounts, 2 pieces of extrusion and attachment hardware
 -32" - 55" monitor size; max weight 20 lbs. each

-Monitor mounts must be placed on opposite sides of the frame for counter balance weight
 -Standard height location; on-center at 66" h from the bottom

dimensions:

Hardware

Assembled unit:
 43.58" w X 16.7" h X 3.6" d

Approximate weight with case:
 25 lbs / 11 kgs

Shipping

Packing case(s):
 1 Box

Shipping dimensions:
 49" l X 12" h X 5" d

Approximate total shipping weight (includes cases & graphics):
 26 lbs / 12 kgs



This product may include the following materials for recycle:
 aluminum, cardboard, paper, steel, and plastics.

2 person assembly recommended:



We are continually improving and modifying our product range and reserve the right to vary the specifications without prior notice. All dimensions and weights quoted are approximate and we accept no responsibility for variance. E&OE. See Graphic Templates for graphic bleed specifications.

12/27/2019

Included in your kit:

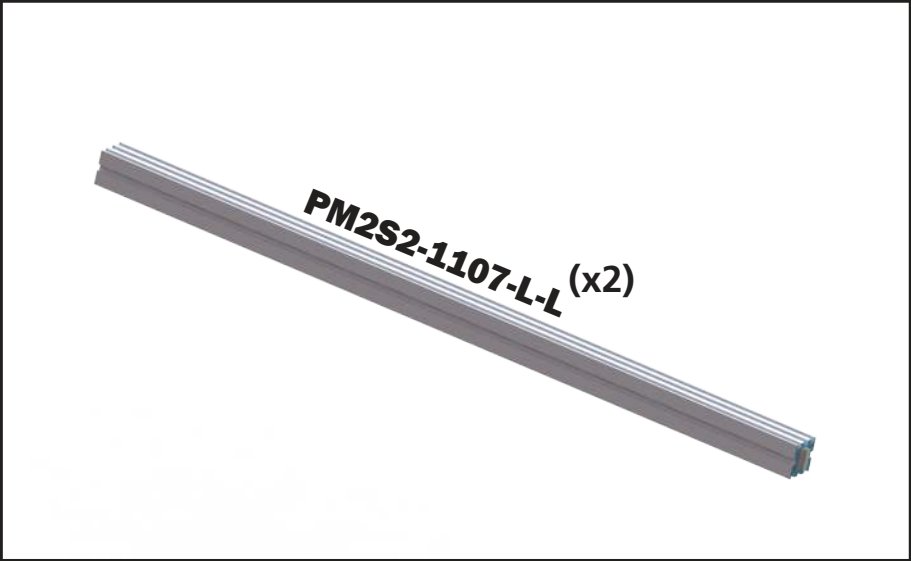

EXT-M-MB
Vesa Pattern: 200 x 200
up to 400 x 400mm
Max weight varies per application

Assembled unit:
17.6" w x 16.7" h x 1.6" d
448mm (w) x 425mm (h) x 40mm (d)

Recommended monitor sizes:
32" - 55"

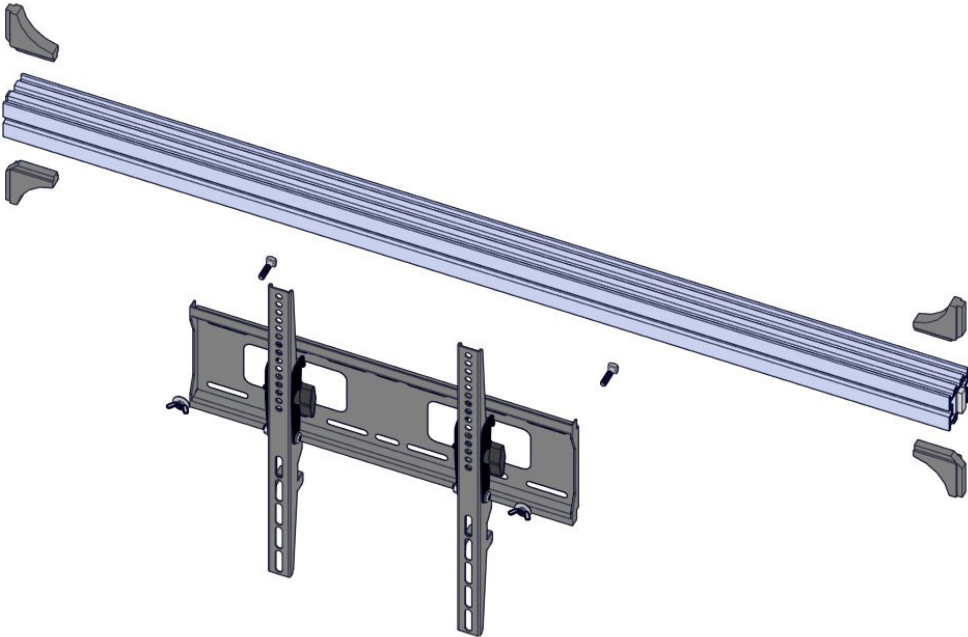
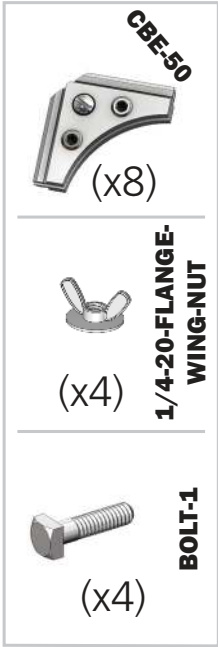

Monitor to Tower Assembly

For this step you will need:

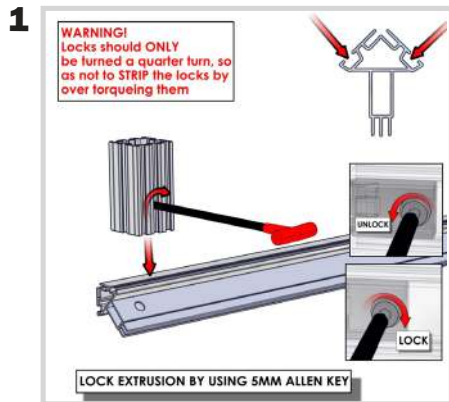

Slide the PM2S2 into the channels of your PMFC2-90 extrusions. Using your Allen-T lock the PM2S2 into place.

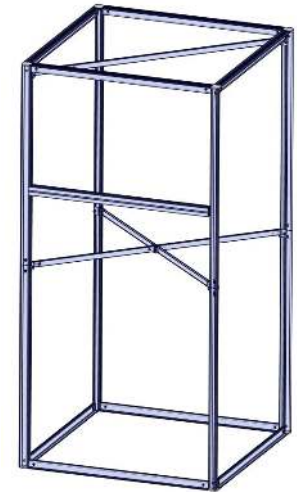
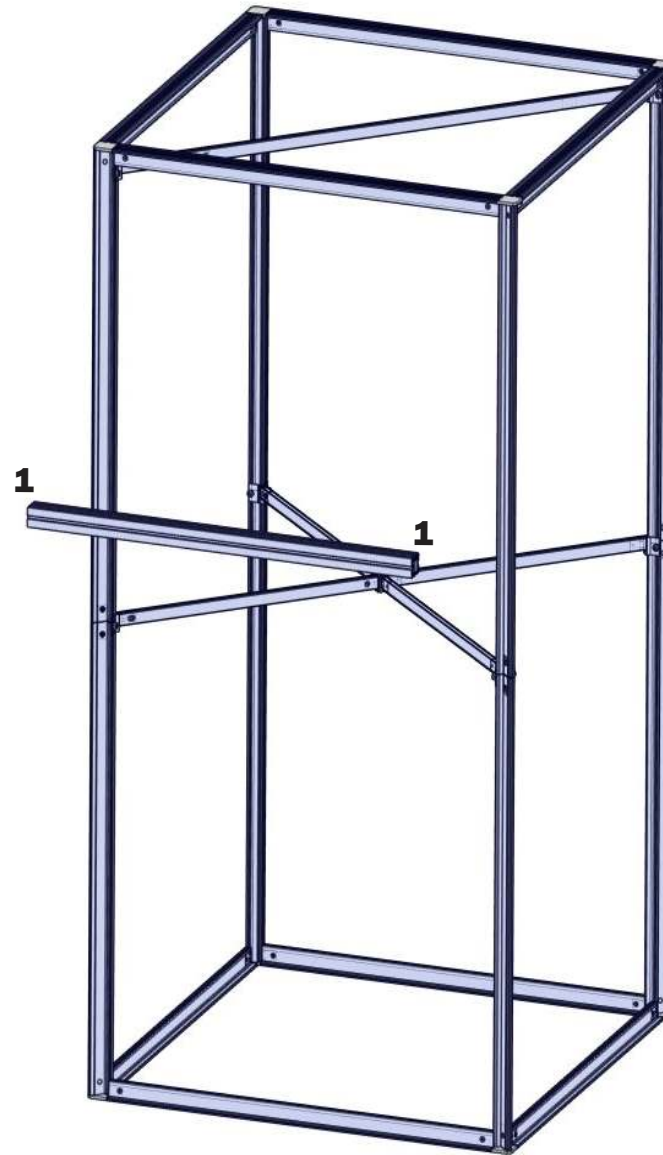

Completed Step.

Note: Should be placed at 66" on center from floor to line up with the graphic hole placement (unless custom height was requested).

Monitor to Tower Assembly

For this step you will need:

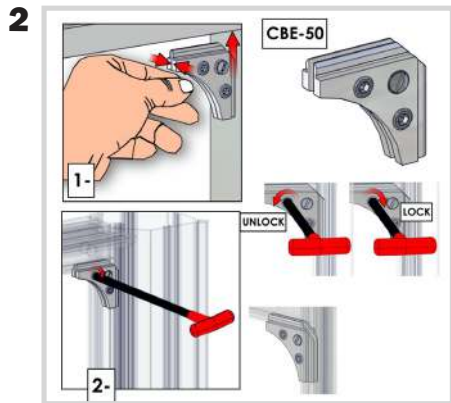
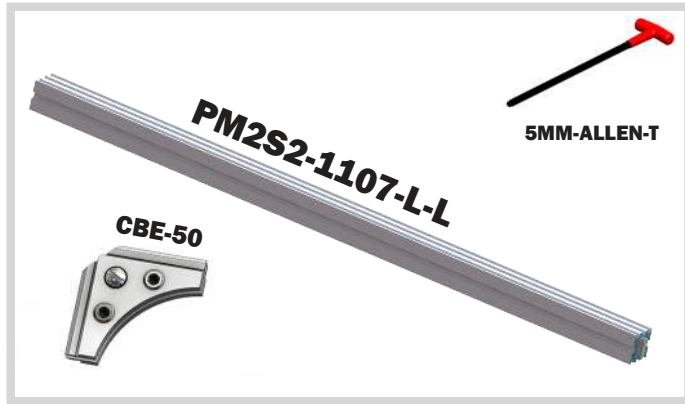

At the 4 corners of the PM2S2 to PMFC2-90 connection you made in the previous step, attach CBE-50s using the Allen-T to add stability to your monitor attachment.

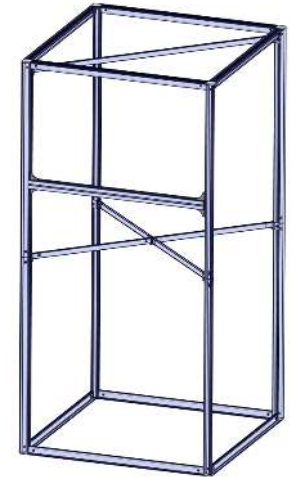
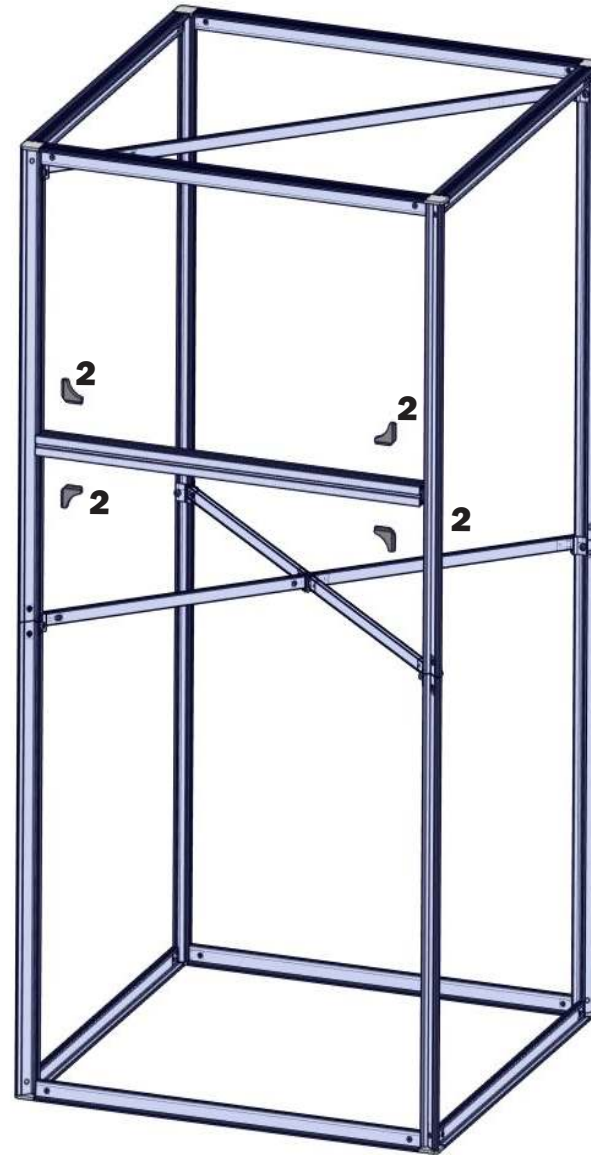

Completed Step.

Monitor to Tower Assembly

For this step you will need:

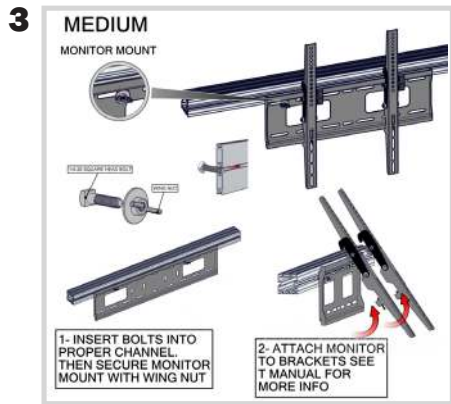

Using the bolt and wing nut you can now attach your monitor mount to the PM2S2.

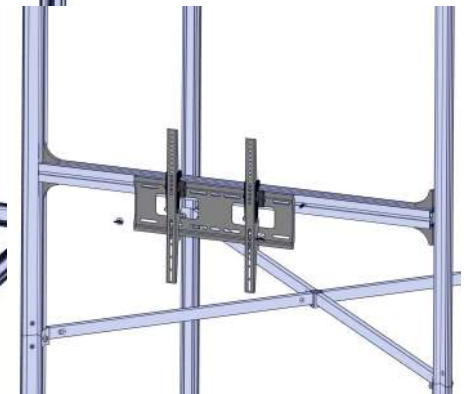
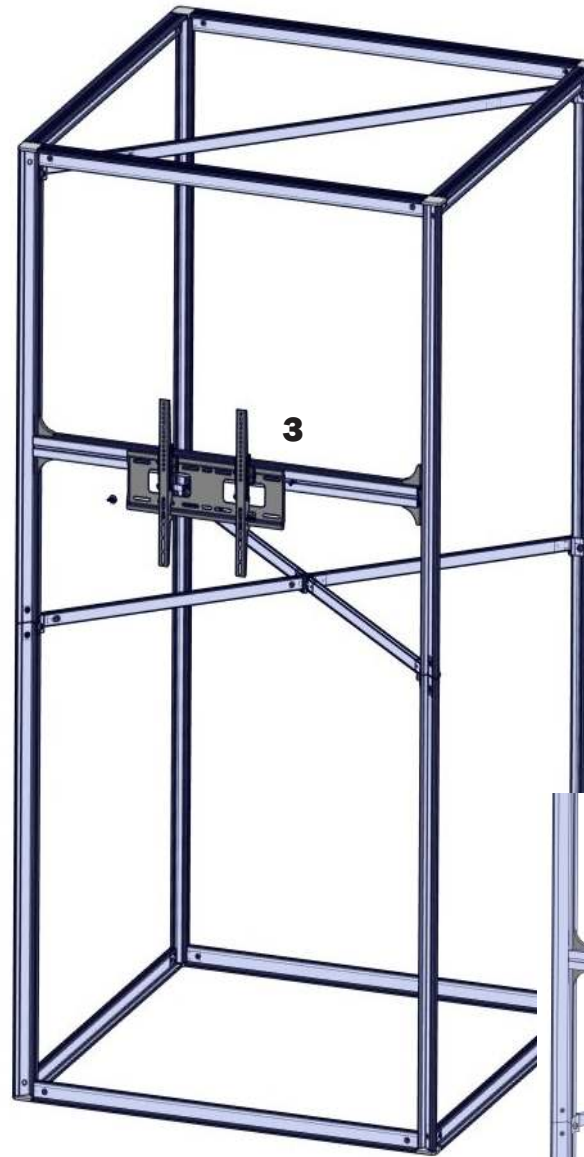

Monitor to Tower Assembly

You may now hang your monitor.

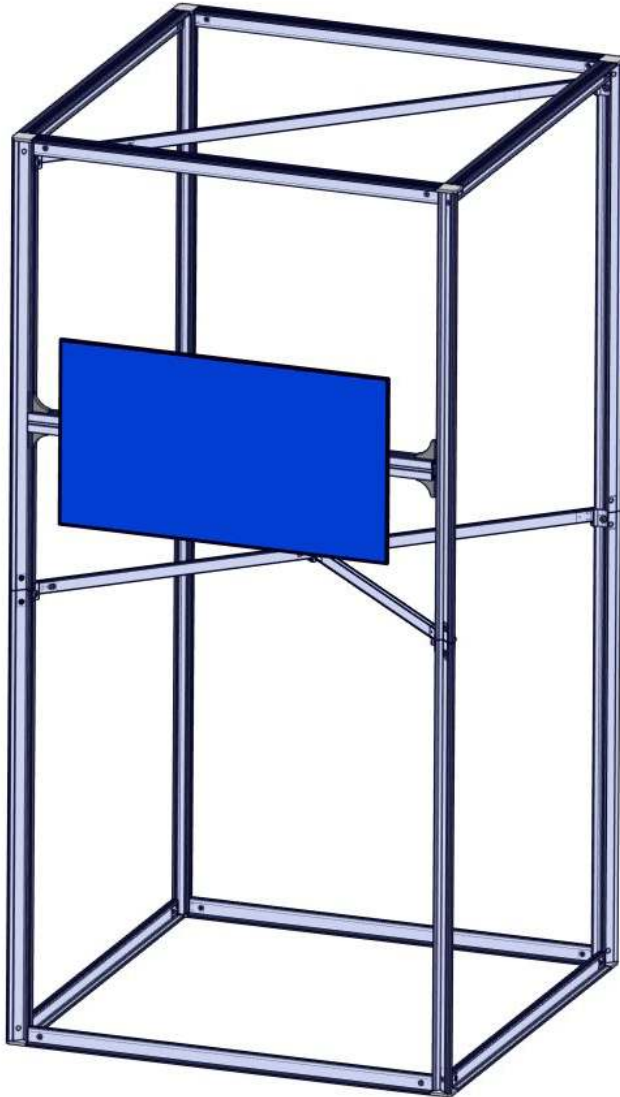

Repeat steps on the opposite side to ensure stability.

